

**FONDOVALLE**

**the book**

0



# contents

02	<b>The Brand</b>
48	<b>The Collections</b>
	<b>Concrete effect</b>
52	Homescape
66	Pigmento
86	Urban Craft
100	Portland
130	Action
	<b>Resin effect</b>
142	Res Art
	<b>Marble effect</b>
166	Infinito 2.0
	<b>Stone effect</b>
344	Background
362	Royal Travertino
376	Upper
390	Keynote
402	Reframe
412	Shards
422	Planeto
454	Stone Lab
	<b>Wood effect</b>
464	Woodblock
476	Komi
	<b>Metal effect</b>
500	Acidic
	<b>Pure effect</b>
512	Monochrome
	<b>Textile effect</b>
520	Dream
	<b>Wall Collections</b>
554	Brit
566	Tech info

# the brand



Da oltre 50 anni uniamo la nostra tradizione ceramica con un'innovazione tecnologica e uno stile che guardano al futuro. Ora siamo parte di Italcera, un Gruppo internazionale che racchiude con i propri marchi il meglio della produzione ceramica e dell'arredo bagno, orientato ad espandere e consolidare la nostra visione. Ricerca e progettazione sono alla base di un pensiero che ci spinge ad andare oltre la mera produzione di superfici, per esprimere qualità che restano nel tempo.

## Vision

# guardiamo oltre la superficie

We look beyond the surface  
Nous regardons au-delà de la surface  
Wir blicken über die Oberfläche hinaus

For over 50 years we have combined our ceramics-making tradition with innovative technology and a forward-thinking style. Now, we are part of Italcera, an international group that gathers together the most reputable ceramic tile and bathroom furnishings brands under its name and whose orientation will help us to expand and consolidate our vision. Supported by our research and design activities, we think beyond the mere manufacture of tiles, striving instead to produce lasting quality.

Depuis plus de 50 ans, nous combinons notre tradition céramique avec l'innovation technologique et un style tourné vers l'avenir. Nous faisons désormais partie d'Italcera, un groupe international dont les marques englobent le meilleur de la production céramique et de la décoration de salles de bains, destiné à développer et à consolider notre vision. La recherche et la conception sont à la base d'une pensée qui nous pousse à aller au-delà de la simple production de carrelages, pour exprimer des qualités indélébiles dans le temps.

Seit über 50 Jahren verbinden wir unsere keramische Tradition mit einer technologischen Innovation und einem Stil, die in die Zukunft blicken. Wir sind jetzt Teil von Italcera, einem internationalen Konzern, der unter seinen Marken das Beste aus der Keramikproduktion und der Badezimmereinrichtung umfasst, und zielen darauf ab, unsere Vision zu erweitern und zu festigen. Forschung und Entwurf sind die Grundlage eines Gedankens, der uns veranlasst, über die reine Herstellung von Oberflächen hinauszugehen und eine Qualität zum Ausdruck zu bringen, die die Zeit überdauert.

Ceramica Fondovalle è tra le aziende leader di mercato in ambito internazionale nella produzione e commercializzazione di lastre e piastrelle in gres porcellanato. Un traguardo frutto di un percorso fatto di competenza produttiva e sperimentazione, unito a un "saper fare" proprio della nostra tradizione italiana, mirabilmente espresso in superfici capaci di coniugare forza e bellezza, per costruire nuovi scenari in cui è piacevole vivere.

## Values

# tecnologia e cultura ceramica

Ceramic technology and culture  
Technologie et culture de la céramique  
Technologie und Kultur der Keramik



Ceramica Fondovalle is one of the leading international companies for the production and marketing of porcelain stoneware slabs and tiles. Our success is the result of productive competence and experimentation, together with a "know-how" that is typical of our Italian tradition, excellently expressed in surfaces that bring together strength and beauty, to create new beautiful environments in which to live.

Ceramica Fondovalle est l'une des principales entreprises sur le marché international dans le domaine de la production et de la commercialisation de dalles et de carreaux en grès cérame. Un objectif qui est le résultat d'un parcours fait de compétence productive et d'expérimentation, associé à un « savoir-faire » typique de notre tradition italienne, admirablement exprimé dans des surfaces capables d'allier force et beauté, pour construire de nouveaux scénarios dans lesquels il est agréable de vivre.

Ceramica Fondovalle ist eines der führenden Unternehmen auf dem internationalen Markt für die Herstellung und Vermarktung von Platten und Fliesen aus Feinsteinzeug. Ein Ziel, das Ergebnis eines Weges bestehend aus produktiver Kompetenz und Erprobung, verbunden mit einem für unsere italienische Tradition typischen „Know-how“ ist, das wunderbar in Oberflächen zum Ausdruck kommt, die in der Lage sind, Stärke und Schönheit zu verbinden, um neue Szenarien entstehen zu lassen, in denen es angenehm ist, zu leben.



Per noi il concetto di stile è legato a un'idea di tempo e spazio, non ha a che fare con la moda ma si nutre di rapporti virtuosi e in divenire tra creatività e tecnologia, sensibilità e armonia. Ogni nuova texture ceramica è qualcosa di magico, che porta linfa nuova, suggerisce idee e una voglia di sperimentare che si rinnovano ogni giorno, per contribuire a trasformare ogni spazio in una dimensione diversa e bellissima, in perfetta sintonia con i vostri desideri più veri.

## Style

# vivide emozioni nello spazio e nel tempo

Vivid emotions in space and time  
Des émotions vives dans l'espace et le temps  
Lebendige Emotionen im Raum und in der Zeit

For us the concept of style is linked to an idea of time and space. It has nothing to do with fashion but it is based on virtuous and constantly changing relationships between creativity and technology, sensitivity and harmony. Each new ceramic texture is something magical, creating new life, proposing ideas and a desire to experiment that is constantly evolving, to help transform every space into a different and beautiful dimension, in perfect harmony with your deepest dreams.

Pour nous, le concept de style est lié à une idée du temps et de l'espace, il n'a rien à voir avec la mode, mais il se nourrit de relations vertueuses et évolutives entre créativité et technologie, sensibilité et harmonie. Chaque nouvelle texture de céramique est quelque chose de magique, apportant une nouvelle vie, suggérant des idées et une envie d'expérimenter qui se renouvellent chaque jour, pour aider à transformer chaque espace en une dimension différente et magnifique, en parfaite harmonie avec vos désirs les plus réels.

Für uns ist das Konzept des Stils mit einer Vorstellung von Zeit und Raum verbunden. Es hat nichts mit Mode zu tun, sondern wird durch virtuose und sich entwickelnde Beziehungen zwischen Kreativität und Technologie, Sensibilität und Harmonie gefördert. Jede neue keramische Textur ist etwas Magisches, das neues Leben mitbringt, Ideen und den Wunsch nach Experimenten suggeriert, die sich jeden Tag erneuern, um jeden Raum in eine andere und schöne Dimension zu verwandeln, die in perfektem Einklang mit Ihren wahrsten Wünschen steht.

Siamo molto sensibili alle tematiche di sostenibilità ambientale e cerchiamo ogni giorno di adeguare i nostri comportamenti ed investimenti nel rispetto di questa priorità, migliorando i nostri processi produttivi per ridurre gli sprechi, ottimizzare le risorse energetiche e contribuire a rafforzare un concetto di qualità 'sostenibile'. In quest'ottica da anni aderiamo al programma Life+, finanziando importanti progetti pilota, aventi come obiettivo lo sviluppo di nuove politiche ambientali per l'Unione Europea, attraverso la realizzazione di strumenti, tecnologie e metodologie all'avanguardia.

## Environment

# il nostro impegno per un futuro sostenibile

Our commitment to a sustainable future  
Notre engagement pour un avenir durable  
Unsere Bemühung um eine nachhaltige Zukunft

Our every action seeks to make our surfaces safer and better performing and so we invest in environmental protection, improving all of our production processes with the aim of reducing waste, optimising energy resources and helping to strengthen a concept of 'sustainable' quality. With this in mind, we have been part of the Life+ program for years, funding important pilot projects with the goal of developing new environmental policies for the European Union, through the creation of cutting-edge tools, technologies and methodologies.

Chaque action que nous entreprenons va dans le sens d'une plus grande sécurité et efficacité de nos surfaces, en investissant dans la protection de l'environnement, en améliorant tous les processus de production afin de réduire les déchets, optimiser les ressources énergétiques et contribuer au renforcement d'un concept de qualité « durable ». De ce point de vue, nous participons au programme Life+ depuis des années, en finançant d'importants projets pilotes dans le but de développer de nouvelles politiques environnementales pour l'Union européenne, grâce à la mise en œuvre d'outils, de technologies et de méthodologies de pointe.

Jede unserer Maßnahmen zielt darauf ab, unsere Oberflächen sicherer und effizienter zu machen, indem wir in den Umweltschutz investieren, alle Produktionsprozesse verbessern, die Abfälle reduzieren, Energieressourcen optimieren und zur Stärkung eines Konzeptes für „nachhaltige“ Qualität beitragen. In diesem Hinblick nehmen wir seit Jahren am Programm Life + teil und finanzieren große Pilotprojekte, die auf die Entwicklung neuer Umweltpolitiken für die Europäische Union durch die Schaffung modernster Instrumente, Technologien und Methoden abzielen.



ITALCER - WINNER OF THE  
2022 SUSTAINABILITY AWARD





Il nostro gres porcellanato interpreta con forza e naturalezza il carattere originale e unico di superfici con ispirazioni materiche differenti, esaltate dal grande formato delle lastre. Un'offerta in grado di soddisfare tutte le esigenze proprie dell'architettura contemporanea, per arredare con soluzioni raffinate e funzionali ambienti originali e creativi, garantendo la massima progettualità e un perfetto coordinamento stilistico a pavimento e rivestimento.

## Products

# abbiamo tutto ciò che state cercando

We have everything you need  
Nous avons tout ce que vous cherchez  
Wir haben alles, was Sie suchen

Our porcelain stoneware interprets with strength and naturalness the original and unique character of surfaces using a variety of materials, enhanced by the large size of the slabs. Our range is able to satisfy all the needs of contemporary architecture, to furnish original and creative environments with refined and functional solutions, guaranteeing maximum planning and perfect stylistic coordination for floors and walls.

Notre grès cérame interprète avec force et naturel le caractère original et unique de surfaces avec des inspirations matérielles différentes, mises en valeur par la grande taille des dalles. Une offre capable de satisfaire toutes les exigences de l'architecture contemporaine, pour meubler des environnements originaux et créatifs avec des solutions raffinées et fonctionnelles, en garantissant un design maximal et une parfaite coordination stylistique des revêtements de sol et muraux.

Unser Feinsteinzeug interpretiert mit Kraft und Natürlichkeit den ursprünglichen und einzigartigen Charakter von Oberflächen mit Inspirationen durch verschiedene Materialien, die durch das große Format der Platten verstärkt werden. Ein Angebot, das allen Anforderungen der modernen Architektur gerecht wird, um mit raffinierten und funktionalen Lösungen originelle und kreative Umgebungen zu gestalten, wobei die maximale Planung und die perfekte stilistische Koordination für Boden- und Wandbelag gewährleistet werden.

Offriamo superfici versatili e trasversali che seguono i luoghi dell'abitare contemporaneo modulandosi in forme differenti per abbracciare qualsiasi destinazione d'uso in ambito residenziale e commerciale. Grandi lastre a spessore sottile danno vita a una nuova progettualità, capace di esprimersi attraverso forme e volumi che si aprono anche sull'esterno, grazie a potenziate caratteristiche di resistenza e durevolezza nel tempo.

## Applications

# ogni spazio è un progetto esclusivo

Each space is a unique project  
Chaque espace est un projet exclusif  
Jeder Raum ist ein exklusiver Entwurf



We offer versatile and transversal surfaces suitable for the spaces of contemporary living, modifying them into different shapes to accommodate any intended use in the residential and commercial sector. Large thin slabs facilitate new designs, skilfully expressed through shapes and volumes that also open onto the outside, thanks to enhanced characteristics of resistance and durability over time.

Nous proposons des surfaces polyvalentes et transversales qui suivent les lieux de vie contemporains, en se modulant sous différentes formes pour embrasser tout usage dans les milieux résidentiels et commerciaux. Des dalles larges et fines donnent vie à une nouvelle conceptualité, capable de s'exprimer à travers des formes et des volumes qui s'ouvrent également sur l'extérieur, grâce à une résistance et à une durabilité accrues.

Wir bieten vielseitige und transversale Oberflächen an, die den Orten des modernen Wohnens folgen und in verschiedenen Formen moduliert werden, um jeden Verwendungszweck in Wohn- und Gewerbebereichen zu berücksichtigen. Große Platten mit geringer Stärke verleihen neuen Entwurfsmöglichkeiten Leben, die sich durch Formen und Volumen ausdrücken können, die sich dank verbesserter Widerstandsfähigkeit und Haltbarkeit im Laufe der Zeit auch nach außen öffnen.





Project Division è la divisione di Ceramica Fondovalle che si occupa della progettazione e applicazione di facciate ventilate, pavimenti sopraelevati e autoposanti, fornendo soluzioni su misura tarate sulle esigenze di clienti, architetti e professionisti del settore. Esperienza e specifiche competenze tecniche consolidate nel tempo, garantiscono un'accurato servizio di assistenza in tutte le fasi di sviluppo, dall'idea iniziale al progetto esecutivo, dalla fornitura del materiale fino alla posa in opera per costruire opere di grande impatto visivo che sfidano il tempo.

## Project Division

# soluzioni su misura per l'architettura

Tailor-made solutions for architecture  
Des solutions sur mesure pour l'architecture  
Maßgeschneiderte Lösungen für die Architektur

The Project Division is the department of Ceramica Fondovalle that deals with the design and application of ventilated façades as well as raised and free-standing floors, providing custom solutions that are tailored to the requirements of customers, architects and professionals in the sector. Experience and specific technical skills gained over years of experience guarantee a targeted assistance service throughout the project: from the initial idea to the executive project, from the supply of the material to the installation resulting in the creation of stunning and timeless environments.

Project Division est la division de Ceramica Fondovalle qui s'occupe de la conception et de l'application des façades ventilées, des planchers surélevés et des sols autoportants, en fournissant des solutions sur mesure calibrées aux besoins des clients, des architectes et des professionnels du secteur. L'expérience et les compétences techniques spécifiques consolidées au fil du temps, garantissent un service d'assistance précis dans toutes les phases du développement: de l'idée initiale au projet exécutif, de la fourniture du matériel à l'installation pour réaliser des ouvrages de grand impact visuel qui défient le temps.

Project Division ist die Abteilung von Ceramica Fondovalle, die sich mit dem Entwurf und der Anwendung von hinterlüfteten Fassaden, Hohlraumböden und selbstliegenden Böden befasst sowie maßgeschneiderte Lösungen liefert, die auf die Bedürfnisse von Kunden, Architekten und Fachleuten der Branche zugeschnitten sind. Erfahrung und spezifische technische Fähigkeiten, die im Laufe der Zeit gefestigt wurden, garantieren einen sorgfältigen Assistenzservice in allen Entwicklungsphasen: von der anfänglichen Idee zum Ausführungsentwurf bzw. von der Lieferung des Materials bis zur Installation, um Bauwerke mit großer visueller Wirkung zu errichten, die der Zeit trotzen.

Shape è la linea di complementi d'arredo firmata Ceramica Fondovalle, studiata per personalizzare ogni ambiente con soluzioni coordinate ai rivestimenti o che giocano attraverso interessanti contrasti di materie e forme. Le potenzialità tecniche ed estetiche del gres porcellanato vengono applicate al mondo dell'interior design, attraverso un'ampia gamma di lastre tra cui scegliere, secondo una visione di stile dal design rigoroso ed essenziale che esalta la bellezza della materia d'ispirazione.

**shape** CUT  
YOUR  
STYLE

## superfici uniche per progetti integrati

Unique surfaces for integrated projects  
Des surfaces uniques pour des projets intégrés  
Einzigartige Oberflächen für integrierte Entwürfe

Shape is the line of furnishing accessories developed by Ceramica Fondovalle, designed to customise any environment with solutions coordinated with wall and floor tiles to create innovative contrasts of materials and shapes. The technical and aesthetic potential of porcelain stoneware is applied to the world of interior design, with a wide range of slabs to choose from, boasting a vision of style with a rigorous, yet essential design that enhances the beauty of the chosen material.

Shape est la ligne d'accessoires d'ameublement signée Fondovalle destinée à personnaliser chaque espace avec des solutions assorties aux revêtements ou jouant à travers d'intéressants contrastes de matières et de formes. Le potentiel technique et esthétique du grès cérame est appliqué au monde de la décoration intérieure, à travers une large gamme de dalles à choisir, selon une vision de style au design rigoureux et essentiel qui met en valeur la beauté de la matière qu'il inspire.

Shape ist die von Ceramica Fondovalle signierte Linie der Einrichtungselemente zur Gestaltung jedes Raumes mit zu den Wand- oder Bodenbelägen abgestimmten oder mittels interessanter Kontraste von Materien und Formen spielenden Lösungen. Die technischen und ästhetischen Möglichkeiten des Feinsteinzeugs werden auf die Welt des Interior Designs angewandt, indem eine große Palette von Platten zur Auswahl steht. Dabei handelt es sich um eine Stilvision mit einem strengen und wesentlichen Design, die die Schönheit des inspirierenden Materials verstärkt.







20 THE BRAND\_SHAPE



21 THE BRAND\_SHAPE













Come in un atelier Ceramica Fondovalle raccoglie e sviluppa ispirazioni e suggestioni provenienti dalla natura, da sperimentazioni grafiche, da intrecci di textures e colori ricercati, per offrire un'ampia gamma di superfici ceramiche che indagano la specificità di materiali diversi e tra loro complementari. Una palette ricca e variegata, estesa su grandi formati per indoor&outdoor, da cui attingere per esclusivi mix&match.

## Effects

# combinazioni creative di colore e texture

Creative combinations of colour and texture  
Des combinaisons créatives de couleur et de texture  
Kreative Kombinationen aus Farbe und Texturen

As in an atelier, Ceramica Fondovalle collects and develops inspirations and ideas inspired by nature, by graphic experiments, by an interweaving of textures and sophisticated colours, to offer a wide range of ceramic surfaces that explore the specificity of varying and complementary materials. An intense and varied palette that now includes large formats for indoor & outdoor use. Perfectly suited for exclusive mix&match laying solutions.

Comme dans un atelier, Ceramica Fondovalle recueille et développe des inspirations et des suggestions provenant de la nature, à partir d'expérimentations graphiques, d'enchevêtrements de textures et de couleurs raffinées, pour offrir une large gamme de surfaces céramiques qui étudient la spécificité de matériaux différents et complémentaires. Une palette riche et variée, étendue à de grands formats pour un usage intérieur et extérieur, très utile pour réaliser des mix&match exclusifs.

Wie in einem Atelier sammelt und entwickelt Ceramica Fondovalle Inspirationen und Eindrücke aus der Natur, aus grafischen Versuchen, aus Verflechtungen edler Texturen und Farben, um eine breite Palette von Keramikoberflächen anzubieten, die die Besonderheiten der verschiedenen und untereinander komplementären Materialien untersuchen. Eine reichhaltige und vielfältige Palette, die auch große Formate für den Innen- und Außenbereich umfasst, auf die man für exklusive Mix&Match zurückgreifen kann.

La ceramica è una superficie naturale, resistente e di lunga durata. Anallergica, inodore, semplice da pulire anche senza l'utilizzo di agenti chimici aggressivi, non trattiene sporco e batteri. Inoltre è un materiale completamente ignifugo, non contiene plastica ed è quindi riciclabile. Una scelta sicura per rivestire di bellezza e praticità ogni spazio, rispettando ambiente e salute.

## Safety

# la bellezza è fatta anche di serenità

Beauty is also linked to unprecedented ease of mind  
La beauté est aussi faite de sérénité  
Schönheit besteht auch aus Unbeschwertheit

Ceramic is a natural, resistant and durable surface. Hypoallergenic, odourless, easy to clean even without the use of aggressive chemical agents, it does not retain dirt and bacteria. It is also a completely fireproof material and as it does not contain plastic it is therefore recyclable. A safe choice to cover every space with beauty and practicality while respecting the environment and health.

La céramique est une surface naturelle, durable et résistante. Hypoallergénique, inodore, facile à nettoyer même sans utiliser de produits chimiques agressifs, elle ne retient ni la saleté ni les bactéries. Il s'agit également d'un matériau totalement ignifuge, qui ne contient pas de plastique et qui est donc recyclable. Un choix sûr pour revêtir tout espace de beauté et de praticité, en respectant l'environnement et la santé.

Keramik ist eine natürliche, widerstandsfähige und langlebige Oberfläche. Sie ist anallergisch, geruchlos, auch ohne Verwendung aggressiver Chemikalien leicht zu reinigen und nimmt Schmutz und Bakterien nicht auf. Außerdem ist sie ein vollkommen feuerfestes Material, enthält keinen Kunststoff und ist daher wiederverwendbar. Eine sichere Wahl, um jeden Raum mit Schönheit und Zweckmäßigkeit zu kleiden und dabei Umwelt und Gesundheit zu schützen.







Advance® è una ceramica antibatterica da pavimento e rivestimento eco-compatibile in gres porcellanato, realizzata in primo ed unico fuoco, ad oltre 1200 gradi di cottura e con il 40% di materie prime riciclate, adatta sia per soluzioni residenziali che non residenziali. L'innovativa tecnologia Advance® può essere applicata a tutte le collezioni di Ceramica Fondovalle e, grazie alle sue proprietà antivirali, antibatteriche e fotocatalitiche, protegge gli spazi rendendoli più salubri, contrastando significativamente l'inquinamento ambientale.



## superfici antibatteriche: igiene e sicurezza da toccare con mano

Antibacterial surfaces:  
hygiene and safety at your fingertips  
Surfaces antibactériennes :  
hygiène et sécurité à toucher de la main  
Antibakterielle Oberflächen:  
Hygiene und Sicherheit, die man fühlt

Advance® porcelain stoneware floor and wall tiles are antibacterial and environment-friendly as they feature 40% recycled raw materials and are single-fired at over 1200°. Suitable for both residential and non-residential solutions, the innovative technology used in Advance® can be applied to all Ceramica Fondovalle collections and, thanks to its antiviral, antibacterial, and photocatalytic properties, it protects whatever area it is installed in, making it healthier, and provides a significant tool to counter environmental pollution.

Advance® est une céramique antibactérienne de sol et de revêtement écopatible en grès cérame, réalisée en première et en simple cuisson, à plus de 1200 degrés et avec 40 % de matières premières recyclées, adaptée aux solutions résidentielles et non résidentielles. La technologie innovante Advance® peut être appliquée à toutes les collections de Ceramica Fondovalle et, grâce à ses propriétés antivirales, antibactériennes et photocatalytiques, elle protège les espaces en les rendant plus sains, en luttant de manière significative contre la pollution de l'environnement.

Advance® ist eine umweltfreundliche antibakterielle Keramik für Boden- und Wandbeläge aus Feinsteinzeug, die mit einem einzigen Brennen bei über 1200 Grad und mit 40% recycelten Rohstoffen hergestellt wird und sowohl für Lösungen in Wohn- als auch Nichtwohnbereichen geeignet ist. Die innovative Technologie Advance® kann auf alle Kollektionen von Ceramica Fondovalle angewendet werden und schützt dank ihrer antiviralen, antibakteriellen und photokatalytischen Eigenschaften die Räume, macht sie gesünder und wirkt der Umweltverschmutzung deutlich entgegen.

- > **Elimina i virus**  
Eliminates viruses | Élimine les virus | Eliminiert viren
- > **Combatte i batteri**  
Fights bacteria | Combat les bactéries | Bekämpft bakterien
- > **Riduce l'inquinamento atmosferico**  
Reduction of atmospheric pollution | Réduction de la pollution atmosphérique | Reduzierte umweltverschmutzung
- > **Combatte lo sporco**  
Combats dirt | Combat la saleté | Bekämpft schmutz
- > **Attenua i cattivi odori**  
Mitigates bad odours | Réduit les mauvaises odeurs | Hemmt üble gerüche



ALL-OVER è una tecnica che permette di riportare la texture della lastra ceramica anche sul bordo, ristampata digitalmente sulla porzione di superficie selezionata, in maniera fedelissima alla grafica di partenza. Questa lavorazione è frutto di una tecnologia produttiva innovativa, concessa in esclusiva a Fondovalle e oggetto di domanda di brevetto, capace di creare un effetto materico delle superfici in gres porcellanato molto più realistico, mantenendo una continuità di texture che dal piano scende e prosegue lungo tutto lo spessore.



## una continuità estetica senza precedenti per superfici che sanno distinguersi

Exclusive aesthetic continuity for surfaces  
that know how to stand out  
Une continuité esthétique sans précédent  
pour des surfaces qui savent se démarquer  
Eine bisher nie erzielte einheitliche Optik  
für Flächenbeläge der besonderen Art

ALL-OVER is a technique that also allows the texture of the ceramic slab to be reproduced on the edge, digitally reprinted on the selected portion of the surface in a way that is very faithful to the original graphic. This process is the result of an innovative production technology – exclusively granted to Fondovalle and the subject of a patent application – that creates a much more realistic textural effect on porcelain stoneware surfaces, maintaining a continuous texture that descends from the top and continues throughout the thickness.

ALL-OVER est une technique qui permet de reproduire la texture de la dalle céramique jusque sur le bord, en réimprimant numériquement la partie sélectionnée de la surface, dans une réplique tout à fait conforme au graphisme d'origine. Ce traitement est le résultat d'une technologie de production innovante, accordée à titre exclusif à Fondovalle et faisant l'objet d'une demande de brevet. Il permet de créer un effet de matière beaucoup plus réaliste sur les surfaces en grès cérame, en maintenant une continuité de texture qui descend du dessus pour se poursuivre sur toute l'épaisseur.

ALL-OVER ist eine Technik, die es ermöglicht, die Textur der Keramikplatte auch auf der Kante wiederzugeben. Per digitalem Druck wird also Oberflächenbild getreu auf diesem Plattenteil reproduziert. Möglich ist dies durch ein innovatives, exklusiv von Fondovalle genutztes Produktionsverfahren, das Gegenstand einer Patentanmeldung ist. Durch die von der Plattenoberseite auf die gesamte Kante übergehende Textur erhält das Feinsteinzeug eine unvergleichlich realistische Materialoptik.







34 THE BRAND\_ALL-OVER

**Kitchen Top**  
Top Cucina

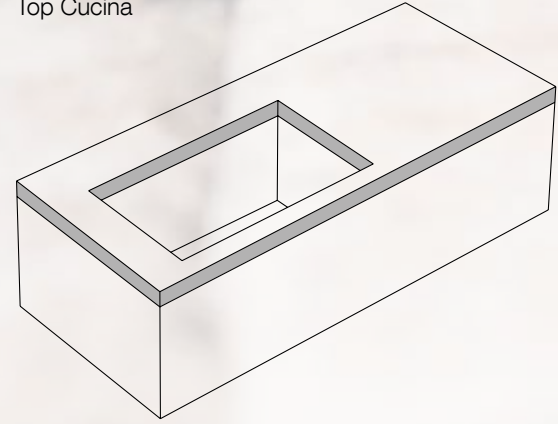

**Shelves and furniture**  
Mensole e mobili

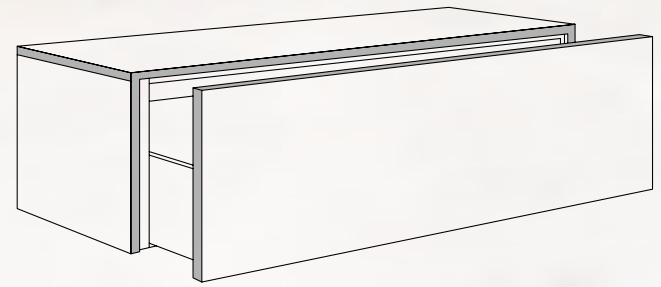

**Bathrooms Top**  
Top bagni

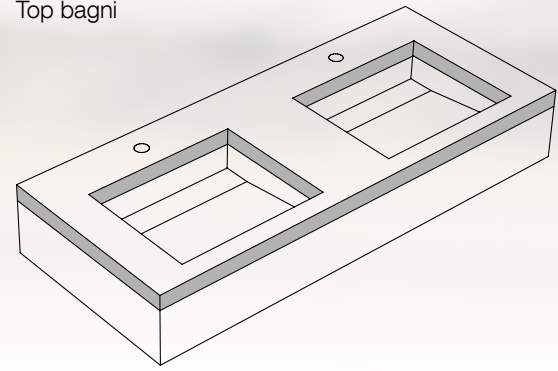

**Tables**  
Tavoli

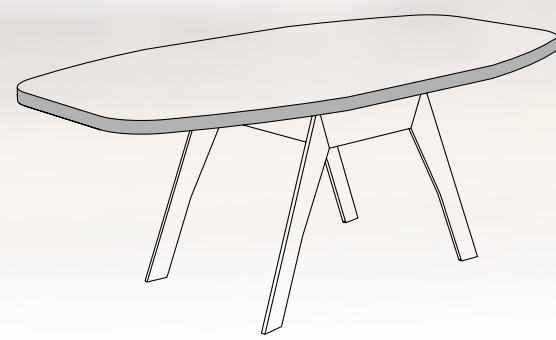

ALL-OVER è stata pensata in particolar modo per rifinire tavoli e mobili della collezione Shape, ma si presta potenzialmente a valorizzare qualsiasi complemento di arredo custom-made o può essere applicata per rifinire dettagli architettonici, oggettistica e progetti di design in cui viene richiesta la massima cura del dettaglio. L'effetto di ALL-OVER ripropone ciò che avviene in natura nelle pietre naturali che si distinguono per le loro variazioni, soprattutto se si considera la superficie orizzontale della lastra rispetto alla costa dove la vena è tagliata trasversalmente ed è quindi, a volte, diversa.



## infinite applicazioni in ambito residenziale e commerciale

Infinite applications in residential and commercial locations  
Une infinité d'applications en résidentiel et en commercial  
Mannigfaltige Anwendungsmöglichkeiten im Wohn- und Objektbereich

**Porcelain stoneware slabs**  
Lastre in gres porcellanto  
Grès cérame plaques  
Feinsteinzeugs platten

**6,5 mm / 8,5 mm / 10 mm / 12 mm / 20 mm**

**6,5 mm / 8,5 mm / 10 mm / 12 mm / 20 mm + 6 mm**  
(Lastra ceramica accoppiata a un vetro temperato  
Ceramic slab coupled with tempered glass  
Dalle en céramique couplée à du verre trempé  
Keramikplatte gekoppelt mit gehärtetem Glas)

ALL-OVER has been especially designed to finish tables and furniture from the Shape collection, but it can potentially be used to enhance any custom-made furniture accessory or applied to finish architectural details, objects and design projects that require the utmost attention to detail. The All-Over look accurately reproduces the effects that occur in the environment with natural stones and their rich variations, especially between the horizontal surfaces of slabs and the edges, which cut through the veining, meaning that the patterning is sometimes different.

ALL-OVER a été spécialement conçue pour la finition des tables et des meubles de la collection Shape, mais elle peut être utilisée pour valoriser n'importe quel élément de décoration sur mesure ou pour la finition de détails architecturaux, d'objets et de projets de design où il est fondamental d'apporter le plus grand soin aux moindres détails. L'effet All-Over reproduit la création de la nature sur les pierres naturelles : des variations typiques, notamment sur la surface horizontale de la dalle par rapport à la tranche, où, du fait de la coupe transversale, la veine est parfois différente.

ALL-OVER wurde speziell für die saubere Ausführung der Tische und Möbel der Kollektion Shape konzipiert, kann sich jedoch auch für die Gestaltung maßgefertigter Einrichtungs-elemente, Detaillösungen und Wohnaccessoires sowie für die Umsetzung von Designprojekten verwendet werden, bei denen es auf fein ausgearbeitete Details ankommt. All-Over bringt Naturstein in seinem ganzen Facettenreichtum zur Geltung, und zwar in der Fortsetzung des Materialbildes der horizontalen Oberfläche auf der Kantenfläche der keramischen Platte, wo die Äderung eine andere Schnittfläche und deshalb bisweilen eine andere Gestalt aufweist.

35 THE BRAND\_ALL-OVER



Fondovalle inaugura una nuova era nella produzione del gres porcellanato grazie a 3D Texture, una tecnologia digitale altamente innovativa che regala una matericità profonda, generando un effetto tridimensionale sulle superfici, fedele all'essenza di ispirazione. La tecnologia 3D Texture consente una perfetta sincronia tra differenti applicazioni e materie con effetti di realismo e profondità di dettaglio straordinari. Il risultato è frutto di investimenti e assidua ricerca, e arricchisce di tridimensionalità l'impasto pressato, cromie e strutture coincidono sinergicamente e le superfici acquistano un'autentica veridicità percepibile sia al tatto che alla vista.



## texture 3D dall'intenso realismo materico

3D Texture with intense material realism  
Des textures matiéristes en 3D extrêmement réalistes  
3D-Oberflächen mit unglaublich realistischer Anmutung

> **Matericità tridimensionale**

Three-dimensionality | Effet matière  
tridimensionnel | Dreidimensionales Materialbild

> **Profondità di dettaglio**

Depth of detail | Profondeur des détails |  
Sorgfältig ausgearbeitete Details

> **Grande naturalezza e veridicità**

Striking naturalness and realism | Un grand naturel et une grande véracité | Natürlichkeit und Authentizität

Fondovalle is heralding a new era in the production of porcelain stoneware thanks to 3D Texture, a highly innovative digital technology that offers a deep material quality, producing a three-dimensional effect on surfaces to accurately resemble the wood that inspired them. 3D Texture technology permits perfect synchronisation between different applications and materials with extraordinarily realistic effects and depth of detail. The result is the fruit of investment and painstaking research, enhancing the three-dimensionality of the pressed mix; colours and textures synergistically harmonise and the surfaces acquire an authenticity perceptible to both touch and sight.

Avec Fondovalle, la production de grès cérame entre dans une nouvelle ère grâce à 3D Texture, une technologie numérique tout à fait innovante qui apporte un rendu fortement matiériste, en créant un effet tridimensionnel sur les surfaces, parfaitement fidèle à l'essence dont elle s'inspire. La technologie 3D Texture permet une synchronisation parfaite entre les différentes applications et matières, avec d'extraordinaires effets de réalisme et de profondeur du détail. Fruit d'un investissement et d'une recherche assidue, le résultat enrichit la pâte pressée d'un effet tridimensionnel. Les couleurs et les structures coïncident en synergie et les surfaces acquièrent une véracité authentique perceptible non seulement à la vue mais aussi au toucher.

Dank der hochinnovativen Digitaltechnik 3D Texture, die eine besondere Materialtiefe erzeugt, eröffnet Fondovalle ein neues Kapitel in der Produktion von Feinsteinzeug. Oberflächen mit plastischer Wirkung geben das zum Vorbild dienende Material äußerst getreu wieder. Die Technik 3D Texture ermöglicht eine vollkommen synchrone Erzeugung von Struktur und Dekor, wodurch eine ungewöhnlich realistische Wirkung und hohen Detailtiefe erzielt wird. Dank Investitionen und intensiver Forschungstätigkeit gelang es, der gepressten Masse eine besondere Tiefenoptik zu verleihen. Durch die passgenaue Übereinstimmung zwischen Farbauftrag und Struktur geben die Oberflächen haptisch wie optisch ein täuschend echtes Bild der Vorlage wieder.







La tecnologia Real Matt regala al gres porcellanato una finitura estremamente matt e molto più opaca rispetto alla finitura Naturale, garantendo massima morbidezza al tatto, facilità di pulizia. Frutto di una costante e appassionata sperimentazione sulla materia ceramica, questa tecnologia consente di annullare completamente gli effetti di riflessione delle superfici. Sovrapposizioni di materie selezionatissime, con bassissimi livelli di gloss, si amalgamano nel supporto ceramico rendendo perfettamente reale l'interpretazione di materiali naturali con i loro molteplici effetti di stonalizzazione.

**REAL  
MATT**  
TECHNOLOGY

## nasce una finitura perfettamente opaca, dal tocco vellutato

Introducing the perfectly matt finish with a velvety touch  
Une finition parfaitement opaque, avec une touche veloutée  
Es entsteht ein perfekt deckendes Finish mit samtiger Haptik

> **Superficie ultra matt, senza riflessioni**

Ultra matt surfaces with no reflections | Surface ultra mat, sans reflets | Ultramatte Oberfläche, ohne Reflexionen

> **Estetica tridimensionale**

Three-dimensional aesthetic | Esthétique tridimensionnelle | Dreidimensionale Ästhetik

> **Morbidezza e facilità di pulizia**

Soft and easy to clean | Douceur et facilité de nettoyage | Geschmeidige Haptik und leichte Reinigung

> **Grande naturalezza**

Extremely natural-looking | Grand naturel | Große Natürlichkeit

> **Massima durevolezza**

Maximum durability | Durée de vie extrême | Maximale Dauerhaftigkeit

Real Matt technology lends porcelain stoneware a highly matt finish (much more so than the unworked finish), guaranteeing maximum softness to the touch and ease of cleaning. The result of constant passionate experimentation with ceramics, this technology removes absolutely all reflections from the tiles. Featuring layer upon layer of only the most select materials and very low levels of gloss, the body of these tiles renders the appearance of their natural counterparts and their multiple shading effects with an absolute realism.

La technologie Real Matt donne au grès cérame une finition extrêmement mate et beaucoup plus opaque que la finition Naturel, garantissant une douceur extrême au toucher et facilitant le nettoyage. Fruit d'une expérimentation constante et passionnée sur la matière céramique, cette technologie permet en effet d'annuler complètement les effets de réflexion des surfaces. Les superpositions de matières très sélectionnées, avec de très faibles niveaux de gloss, s'amalgament dans le support céramique rendant parfaitement réelle l'interprétation de matériaux naturels avec leurs multiples effets de stonalisation.

Die Technologie Real Matt verleiht dem Feinsteinzeug ein extrem mattes Finish und ist wesentlich opaker als das naturelle Finish, was eine maximale taktile Geschmeidigkeit und eine einfache Reinigung garantiert. Diese Technologie ist das leidenschaftlichem Experimentieren mit keramischen Materialien und ermöglicht es, die Reflexionseffekte der Oberflächen vollständig aufzuheben. Überlagerungen ausgewählter Materialien mit sehr niedrigem Glanzgrad fügen sich in den Keramikträger ein und machen die Interpretation natürlicher Materialien mit ihren vielfältigen Schattierungseffekten vollkommen real.



Matt&Deep è un'esclusiva tecnologia produttiva applicata nella lavorazione degli impasti che compongono il nostro gres porcellanato capace di rendere la superficie estremamente opaca, valorizzando al tempo stesso l'aspetto tridimensionale di grafiche e strutture. Sovrapposizioni di materie e pigmenti selezionati, con bassissimi livelli di gloss, si amalgamano in profondità nel supporto ceramico regalando effetti sempre diversi di stonalizzazione che rendono perfettamente reale l'interpretazione di materiali naturali.



## effetti tridimensionali e finitura matt di grande naturalezza

Three-dimensional effects and a very natural matt finish  
Effets tridimensionnels et finition mate  
à l'allure absolument naturelle  
Dreidimensionale Optiken und Mattfinishes von  
beeindruckender Natürlichkeit

> **Bassissimi livelli di riflessione**

Very low degree of reflection | Très faible degré de réflexion | Extrem niedrige Reflexionsniveaus

> **Estetica tridimensionale**

Three-dimensional aesthetic | Esthétique tridimensionnelle | Dreidimensionale Ästhetik

> **Morbidezza e facilità di pulizia**

Soft and easy to clean | Douceur et facilité de nettoyage | Geschmeidige Haptik und leichte Reinigung

> **Profonda variabilità**

Highly variable | Profonde variabilité | In die Tiefe gehende Variabilität

> **Massima resistenza alle sollecitazioni**

Optimum stress resistance | Résistance maximale aux contraintes | Ausgezeichnete Stoßfestigkeit

Matt&Deep is an exclusive production technology applied in processing the mixes that form our porcelain stoneware. It makes the surface extremely matt, while enhancing the three-dimensional appearance of graphic motifs and structures. Overlays of selected materials and pigments with very low gloss levels blend deep in the ceramic substrate, providing ever-varying shading effects that make the interpretation of natural materials perfectly real.

Matt&Deep est une technologie de production exclusive pour façonner les pâtes qui composent notre grès cérame. Elle rend la surface extrêmement mate tout en mettant en valeur l'aspect tridimensionnel des textures graphiques et structures. Des superpositions de matériaux et pigments sélectionnés, avec de très faibles taux de brillance, s'amalgament en profondeur dans le support céramique pour susciter des variations de nuances à chaque fois différentes qui donnent une interprétation parfaitement réaliste des matières naturelles.

Matt&Deep ist eine exklusive Produktionstechnologie, die in der Verarbeitung der Keramikmassen für unser Feinsteinzeug zur Anwendung kommt und dafür sorgt, dass die Oberflächen extrem matt erscheinen, während gleichzeitig der dreidimensionale Aspekt der Grafiken und Strukturen stärker zum Ausdruck kommt. Die Überlagerungen der ausgewählten Materien und Pigmente - mit sehr niedrigen Gloss-Niveaus - verbinden sich in der Tiefe der Keramik-Basismasse und lassen sich dadurch immer wieder neue Farbvariationen entstehen, die eine perfekt wirklichkeitsgetreue Interpretation der natürlichen Materialien gewährleisten.







Versatilità e resistenza sono le due caratteristiche principali delle lastre 2.OUT che possono essere applicate facilmente in ogni contesto, residenziale o commerciale, con posa tradizionale, posa incollata, posa diretta su erba e ghiaia o posa sopraelevata su piedini insieme ad una ricca gamma di pezzi speciali a completamento. Le soluzioni 2.OUT sono perfettamente coordinate ai pavimenti in 8,5, 10 e 6,5 mm, per creare ambienti esterni di grande impatto estetico che diventano la naturale estensione dei propri spazi indoor.

## 2.OUT

### gres porcellanato con spessore 2 cm per riprogettare l'outdoor

Porcelain stoneware 2 cm thick for redesigning the outdoors  
Grès cérame de 2 cm d'épaisseur pour redessiner l'extérieur  
Feinsteinzeug in Stärke 2 cm zur Neugestaltung  
von Außenbereichen

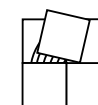

#### Posa tradizionale su massetto

Conventional installation on screed  
Pose traditionnelle sur chape  
Traditionelle Verlegung auf Estrich

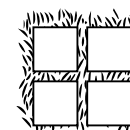

#### Posa su erba

Installation on grass  
Pose sur gazon  
Verlegung auf Gras

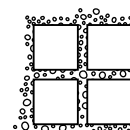

#### Posa su sabbia o ghiaia

Installation on sand or gravel  
Pose sur sable ou gravier  
Verlegung auf Sand oder Kies

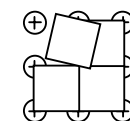

#### Posa sopraelevata su supporti

Raised installation on pedestals  
Pose surélevée sur plots  
Verlegung auf Stelzlagern

Versatility and strength are the two main characteristics of 2.OUT slabs, which can easily be applied in any residential or commercial context, installed by the conventional method, with adhesive, directly placed on grass and gravel, or as a raised paving on pedestals, together with a rich assortment of trims to complete the project. 2.OUT solutions are perfectly matched with the 8,5, 10 and 6.5 mm floor tiles, to create outdoor design schemes with strong aesthetic impact, which become the natural extension of your indoor spaces.

La polyvalence et la résistance sont les deux principaux atouts des dalles 2.OUT qui s'appliquent facilement dans tous les contextes, résidentiels ou commerciaux, en pose traditionnelle, en pose collée, en pose directe sur gazon et sur gravier ou en pose surélevée sur plots, sans oublier la grande variété de pièces spéciales. Les solutions 2.OUT se coordonnent parfaitement aux carreaux de sol de 8,5, 10 et 6,5 mm, de sorte à créer des cadres extérieurs de grand impact esthétique, qui deviennent le prolongement naturel des espaces intérieurs.

Vielseitigkeit und Widerstandsfähigkeit sind die beiden Hauptmerkmale der 2.OUT-Platten, die sich überall, sei es im Wohn- oder Gewerbebereich, einfach und problemlos einsetzen lassen. Sie können traditionell im Kleberbett, direkt auf Gras oder Kies oder aber auf Stelzlagern zusammen mit einer großen Auswahl an Formteilen, die das Sortiment abrunden, verlegt werden. Die 2.OUT-Lösungen sind perfekt auf die Bodenbeläge in 8,5 mm, 10 mm und 6,5 mm Stärke abgestimmt, um ästhetisch ansprechende Außenbereiche zu schaffen, die eine natürliche Erweiterung der Innenräume darstellen.



Ceramica Fondovalle, come parte del gruppo Italcer, adotta e mantiene attivo un processo sistematico di verifica, misura e monitoraggio delle performance dei suoi processi produttivi e gestionali, testimoniato dalle diverse certificazioni ambientali e di sicurezza ottenute negli anni in conformità alle normative di riferimento. Tutto questo rappresenta un percorso di crescita attraverso il quale l'azienda vuole dare il suo contributo ad uno sviluppo sostenibile, operando responsabilmente e in maniera trasparente nei confronti della società e dell'ambiente.

## Certifications

# il nostro impegno di responsabilità sociale e miglioramento continuo

Our commitment to social responsibility and continuous improvement  
 Notre engagement en matière de responsabilité sociale et d'amélioration continue  
 unser Engagement für soziale Verantwortung und kontinuierliche Verbesserung

As member of the Italcer group, Ceramica Fondovalle adopts a systematic procedure for testing, measuring, and monitoring the performance of its production and management processes, as demonstrated by the various environmental and safety certifications obtained over the years testifying to compliance with applicable legislation. This growth pathway has enabled the company to contribute to sustainable development, while also operating responsibly and transparently in its relationships with society and the environment.

Ceramica Fondovalle, dans le cadre du groupe Italcer, adopte et maintient un processus systématique de vérification, de mesure et de suivi des performances de ses processus de production et de gestion, comme en témoignent les différentes certifications environnementales et de sécurité obtenues au fil des ans conformément aux réglementations de référence. Tout cela représente un parcours de croissance à travers lequel l'entreprise veut apporter sa contribution au développement durable, en opérant de manière responsable et transparente vis-à-vis de la société et de l'environnement.

Ceramica Fondovalle wendet als Teil der Gruppe Italcer einen systematischen Prozess zur Überprüfung, Messung und Überwachung der Leistung seiner Produktions- und Managementprozesse an, der durch die verschiedenen Umwelt- und Sicherheitszertifizierungen belegt wird, die im Laufe der Jahre in Übereinstimmung mit den einschlägigen Vorschriften erzielt wurden. Dies alles stellt einen Weg des Wachstums dar, mit dem das Unternehmen seinen Beitrag zu einer nachhaltigen Entwicklung leisten und dabei verantwortungsvoll und transparent gegenüber Gesellschaft und Umwelt handeln will.



## certificazione ISO 9001:2015

ISO 9001:2015 certification | certification ISO 9001:2015 | zertifizierung ISO 9001:2015

La filosofia di Ceramica Fondovalle è da sempre improntata al conseguimento di prodotti tecnicamente all'avanguardia, realizzati con i più elevati standard qualitativi ed estetici. L'Azienda ha scelto di conseguire su base volontaria la Certificazione al Sistema di Qualità UNI EN ISO 9001:2015 per testimoniare l'impegno verso una qualità globale al servizio del Cliente e dei propri dipendenti, attraverso un insieme di azioni che ne garantiscono la massima sicurezza ed efficacia. La Certificazione ISO 9001:2015 sviluppata dall'Organizzazione Internazionale per la Standardizzazione (ISO o International Organization for Standardization), fornisce linee guida e norme utili nel raggiungimento di standard universalmente riconosciuti, in un'ottica di miglioramento continuo dei processi. In questo modo Ceramica Fondovalle assicura costantemente la fornitura di prodotti e servizi che soddisfano e superano i requisiti di legge, quelli normativi e quelli del Cliente, identificando i rischi e le opportunità di miglioramento, per aumentare la propria credibilità attraverso performance accettate a livello mondiale.

The philosophy of Ceramica Fondovalle has always been geared towards delivering technically advanced products, offering superior quality and unrivalled aesthetics. The company has chosen, voluntarily, to obtain UNI EN ISO 9001:2015 quality system certification to demonstrate its commitment to global quality at the service of both its customers and its employees, through a set of actions guaranteeing maximum safety and effectiveness. ISO 9001:2015, developed by the International Organization for Standardization, provides guidelines and rules for the establishment of universally recognised standards, with a view to achieving continuous process improvement. With this certification, Ceramica Fondovalle constantly guarantees products and services that meet and even surpass legal, regulatory, and customer requirements, by identifying risks and opportunities for improvement, and increasing credibility through globally recognised performance.

La philosophie de Ceramica Fondovalle a toujours été marquée par l'obtention de produits techniquement à l'avant-garde, réalisés selon les normes qualitatives et esthétiques les plus élevées. La Société a choisi d'obtenir sur une base volontaire la Certification au Système de Qualité UNI EN ISO 9001:2015 pour témoigner de son engagement envers une qualité globale au service du Client et de ses employés, à travers un ensemble d'actions qui en garantissent le maximum de sécurité et d'efficacité. La Certification ISO:9001:2015, élaborée par l'Organisation Internationale de Normalisation (ISO), fournit des lignes directrices et des règles utiles pour atteindre des normes universellement reconnues, dans une optique d'amélioration continue des processus. De cette façon, Ceramica Fondovalle assure constamment la fourniture de produits et services qui répondent et dépassent les exigences légales, réglementaires et celles du client, en identifiant les risques et les opportunités d'amélioration, afin d'accroître sa crédibilité grâce à des performances acceptées dans le monde entier.

Die Philosophie von Ceramica Fondovalle beruht seit jeher auf der Erzielung technisch fortschrittlicher Produkte, die mit den höchsten qualitativen und ästhetischen Standards hergestellt werden. Das Unternehmen hat beschlossen, die Zertifizierung des Qualitätssystems UNI EN ISO 9001:2015 auf freiwilliger Basis zu erhalten, um sein Engagement für globale Qualität im Dienste des Kunden und seiner Mitarbeiter durch eine Reihe von Maßnahmen zu belegen, die maximale Sicherheit und Wirksamkeit garantieren. Die ISO-Zertifizierung: 9001:2015, entwickelt von der Internationalen Organisation für Standardisierung (ISO oder International Organization for Standardization), liefert Richtlinien und Standards, die zur Erreichung allgemein anerkannte Standards im Hinblick auf eine kontinuierliche Prozessverbesserung nützlich sind. Auf diese Weise stellt Ceramica Fondovalle ständig die Lieferung von Produkten und Dienstleistungen sicher, die die Anforderungen des Gesetzes, der Bestimmungen und des Kunden erfüllen und übertreffen, indem sie Risiken und Verbesserungsmöglichkeiten aufzeigen, um die eigene Glaubwürdigkeit durch weltweit akzeptierte Leistung zu erhöhen.



## Certificazioni ambientali

Environmental Certifications | Certifications Environnementales | Zertifizierungen Umwelt



### EMAS (Eco-Management and Audit Scheme)

È un sistema comunitario di ecogestione e audit creato dalla Comunità Europea, a cui possono aderire volontariamente le imprese che desiderano impegnarsi nel valutare e migliorare la propria efficienza ambientale, fornendo alle organizzazioni e ad altri soggetti informazioni sulle proprie prestazioni. L'azienda deve elaborare un proprio sistema di gestione ambientale (SGA) basato sulla norma ISO 14001:2004 e deve rilasciare una Dichiarazione Ambientale pubblica in cui la qualità del prodotto e il processo produttivo risultino conformi a uno sviluppo economico sostenibile. | This EU-created eco-management and audit scheme is open, voluntarily, to any companies wishing to commit to assessing and improving their environmental efficiency; once they have joined, the scheme provides organisations and any other parties seeking information with details of their performance. The company must develop its own environmental management system (EMS) based on ISO standard 14001:2004 and must issue a public environmental declaration, stating that the quality of the product and the production process comply with sustainable economic development. | Il s' agit d'un système communautaire de gestion environnemental et d'audit créé par la Communauté européenne, auquel peuvent adhérer volontairement les entreprises qui souhaitent s'engager à évaluer et à améliorer leur efficacité environnementale, en fournissant aux organisations et à d'autres parties prenantes des informations sur leurs performances. L'entreprise doit élaborer son propre système de gestion environnementale (SGE) basé sur la norme ISO 14001:2004 et doit publier une Déclaration Environnementale publique dans laquelle la qualité du produit et le processus de production sont conformes à un développement économique durable. | Dabei handelt es sich um ein von der Europäischen Gemeinschaft geschaffenes gemeinschaftliches Umweltmanagement- und Auditsystem, dem Unternehmen, die sich zur Bewertung und Verbesserung ihrer Umwelteffizienz verpflichten möchten, freiwillig beitreten können und Organisationen und anderen Akteuren Informationen über ihre Leistung liefern. Das Unternehmen muss ein eigenes Umwelt-Managementsystem (EMS) auf Basis der Norm ISO 14001:2004 entwickeln und eine öffentliche Umwelterklärung ausstellen, in der die Qualität des Produkts und des Produktionsprozesses einer nachhaltigen wirtschaftlichen Entwicklung entsprechen.



### UNI EN ISO 14001:2015 sistema di gestione ambientale

Environmental management system | Système de gestion environnementale | Umwelt-Managementsystem

La certificazione ISO 14001 attesta i requisiti di un sistema di gestione ambientale adeguato che l'azienda utilizza in modo sistematico per migliorare le proprie prestazioni e ridurre gli impatti ambientali della propria attività. | ISO 14001 certification demonstrates that the company adopts an appropriate environmental management system to improve its performance and reduce the environmental impacts of its business. | La certification ISO 14001 atteste des exigences d'un système de management environnemental adéquat que l'entreprise utilise systématiquement pour améliorer ses performances et réduire les impacts environnementaux de son activité. | Die Zertifizierung ISO 14001 bescheinigt die Anforderungen an ein angemessenes Umwelt-Managementsystem, das das Unternehmen systematisch anwendet, um seine Leistung zu verbessern und die Umweltauswirkungen seiner Tätigkeit zu reduzieren.



### emissioni di COV nell'atmosfera

Emissions into the atmosphere | Émission dans l'air intérieur | Emissionen in die Atmosphäre

Tutte le collezioni di Ceramica Fondovalle hanno ottenuto A+ | All Ceramica Fondovalle's collections have obtained A+ | Toutes les collections de Ceramica Fondovalle ont obtenu A+ | Alle Kollektionen von Ceramica Fondovalle haben A+ erhalten



### EPD - dichiarazione ambientale di prodotto

EPD - Environmental Product Declaration | EPD - Déclaration environnementale de produit | EPD Umwelt-Produkterklärung

Una certificazione volontaria che mette in evidenza le prestazioni ambientali di prodotto/processo/servizio per migliorarne la sostenibilità. | Voluntary certification that highlights a product/process/service's environmental performance and commitment to sustainability. | Une certification volontaire qui met en évidence les performances environnementales des produits/processus/services pour améliorer leur durabilité. | Eine freiwillige Zertifizierung, die die Umweltleistung des Produkts/des Prozesses/der Dienstleistung hervorhebt, um dessen/deren Nachhaltigkeit zu verbessern.

## Certificazioni di prodotto

Product Certifications | Certifications Du Produit | Produktzertifizierungen



## dichiarazione MOCA

Declaration of compliance for FCMs | déclaration MOCA | Erklärung MOCA

La Dichiarazione di Conformità per i MOCA (Materiali e Oggetti a Contatto con Alimenti) è il documento che garantisce il rispetto delle disposizioni del regolamento 1935/2004/CE per tutti i prodotti destinati a venire a contatto con gli alimenti ed ha lo scopo di attestare che vengano rispettate caratteristiche obbligatorie nell'ambito della sicurezza igienico-sanitaria. | The declaration of compliance for FCMs (Food Contact Materials) is the document that guarantees compliance with the provisions of EU Regulation 1935/2004/EC for all products intended to come into contact with food. Its purpose is to certify that specific requirements in the field of health and hygiene safety are met. | La Déclaration de Conformité pour les MOCA (Matériaux et Objets en Contact avec les Aliments) est le document qui garantit le respect des dispositions du règlement 1935/2004/CE pour tous les produits destinés à entrer en contact avec les aliments et vise à attester que les caractéristiques obligatoires sont respectées dans le domaine de la sécurité hygiénique et sanitaire. | Die Konformitätserklärung für MOCA (Materialien und Gegenstände im Kontakt zu Lebensmitteln) ist das Dokument, das die Einhaltung der Bestimmungen der Verordnung 1935/2004/EG für alle Produkte garantiert, die dazu bestimmt sind, mit Lebensmitteln in Kontakt zu gelangen, und die Aufgabe hat, zu bescheinigen, dass diese obligatorischen Eigenschaften im Bereich Gesundheit und Hygiene eingehalten werden.



## SASO - certificazione SQM

SASO - SQM Certification | SASO - Certification SQM | SASO - Zertifizierung SQM

Certificazione di qualità SQM (Saso Quality Mark), riconosciuta da ente saudita di certificazione, finalizzata all'espportazione di prodotti in Arabia Saudita, importante sbocco commerciale del Middle-East. | SQM (Saso Quality Mark) quality certification, awarded by a Saudi certification body for the purposes of exporting products to Saudi Arabia, which is a significant market in the Middle-East. | Certification de qualité SQM (Saso Quality Mark), reconnue par l'organisme de certification saoudien, pour l'exportation de produits vers l'Arabie Saoudite, un important débouché commercial au Moyen-Orient. | SQM-Qualitätszertifizierung (Saso Quality Mark), die von einer saudischen Zertifizierungsstelle anerkannt wird und auf den Export von Produkten nach Saudi-Arabien abzielt, einem wichtigen Handelsplatz im Nahen Osten.



## marcatura CE

CE mark | marquage CE | CE-Kennzeichnung

La marcatura CE garantisce la conformità di prodotto ai requisiti essenziali in ordine alla sicurezza del prodotto e alla salute dell'utilizzatore. | The CE mark guarantees product compliance with the essential requirements concerning product safety and user health. | Le marquage CE garantit la conformité du produit aux exigences essentielles concernant la sécurité du produit et la santé de l'utilisateur. | Die CE-Kennzeichnung garantiert die Konformität des Produktes mit den grundlegenden Anforderungen an die Produktsicherheit und die Gesundheit des Anwenders.



## certificazione CCC

CCC certification | certification CCC | Zertifizierung CCC

Il Certificato Cinese Obbligatorio, conosciuto con l'acronimo CCC (China Compulsory Certification) è un marchio di sicurezza necessario per molti prodotti che accedono al mercato cinese e garantisce un basso contenuto di radio isotopi delle materie prime. | The China Compulsory Certificate (known by the acronym 'CCC') is a safety mark which is required for many products entering the Chinese market and which guarantees that the raw materials used have a low radioisotope content. | La Certification Obligatoire Chinoise, connue sous l'acronyme CCC (China Compulsory Certification), est un label de sécurité requis pour de nombreux produits entrant sur le marché chinois et garantissant une faible teneur en radio-isotopes des matières premières. | Die obligatorische chinesische Zertifizierung, bekannt unter dem Akronym CCC (China Compulsory Certification), ist ein notwendiges Sicherheitszeichen für viele Produkte, die auf den chinesischen Markt kommen und garantiert einen niedrigen Radioisotopengehalt der Rohstoffe.



# the collections



Effetto Cemento  
Effet Béton  
Beton-Effekt

## concrete effect

52 Homescape  
66 Pigmento  
86 Urban Craft  
100 Portland  
130 Action



# homescape



Lastre / piastrelle di ceramica in gres porcellanato - Gruppo Bla UGL  
 Porcelain stoneware slabs / tiles - Gruppe Bla UGL  
 Dalles / carreaux en céramique en grès cérame - Group Bla UGL  
 Keramikplatten / keramikfliesen aus Feinsteinzeug - Gruppe Bla UGL

## THICKNESS

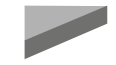

6,5 mm 8,5 mm  
 SELF LEVELING

## SURFACES

**Natural**  
 Rettificato | Rectified |  
 Rectifié | Rektifiziert

## TECH INFO



BS EN 16165\_C >  
 Dry & Wet rubber 4S: ≥ 36  
 AS 4586 > P3  
 UNE-ENV 12633 > Class 2

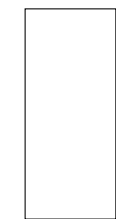

120x278\*  
 47,24"x109,45"



120x120  
 47,24"x47,24"



60x120  
 23,62"x47,24"



80x80  
 31,50"x31,50"

\* Lastre realizzate attraverso impasti colorati con colori standard | Slabs produced using coloured body mix available in standard shades

## COLORS

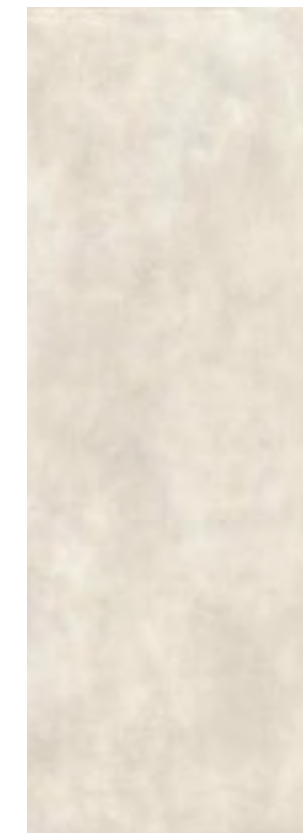

SUGAR



CLAY



COAL



CAMEL



MATCHA





54 HOMESCAPE\_CONCRETE EFFECT

CLAY / CLAY TUB



55 HOMESCAPE\_CONCRETE EFFECT









58 HOMESCAPE\_ CONCRETE EFFECT

59 HOMESCAPE\_ CONCRETE EFFECT

# homescape

60 HOMESCAPE\_CONCRETE EFFECT



## SIZES & SURFACES



**120x278\***  
47,24"x109,45"



**120x120**  
47,24"x47,24"



**60x120**  
23,62"x47,24"



**80x80**  
31,50"x31,50"

**Natural**  
Rettificato | Rectified |  
Rectifié | Rektifiziert

**6,5 mm**

**120x278** . 47,24"x109,45"  
**HOM016**

**120x120** . 47,24"x47,24"  
**HOM006**

**8,5 mm**

**60x120** . 23,62"x47,24"  
**HOM087**

**80x80** . 31,50"x31,50"  
**HOM097**



## HOMESCAPE TUB

**8,5 mm**  
**60x120** . 23,62"x47,24"  
decoro  
**HOM092**

**Suggested grout**  
103 . Moon White



## SIZES & SURFACES



**120x278\***  
47,24"x109,45"

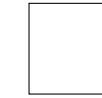

**120x120**  
47,24"x47,24"



**60x120**  
23,62"x47,24"



**80x80**  
31,50"x31,50"

**Natural**  
Rettificato | Rectified |  
Rectifié | Rektifiziert

**6,5 mm**

**120x278** . 47,24"x109,45"  
**HOM017**

**120x120** . 47,24"x47,24"  
**HOM007**

**8,5 mm**

**60x120** . 23,62"x47,24"  
**HOM088**

**80x80** . 31,50"x31,50"  
**HOM098**



## HOMESCAPE TUB

**8,5 mm**  
**60x120** . 23,62"x47,24"  
decoro  
**HOM093**

**Suggested grout**  
187 . Linen



61 HOMESCAPE\_CONCRETE EFFECT

## SUGAR

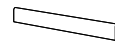

**6,5 mm**  
**8x120** . 3,15"x47,24"  
battiscopa  
**HOM036**



**6,5 mm**  
**33x120x5** . 12,99"x47,24"x1,97"  
gradino lineare LL  
**HOM041**



**6,5 mm**  
**33x120x5** . 12,99"x47,24"x1,97"  
gradino angolare LL  
**HOM046**

**8,5 mm**  
**8x80** . 3,15"x31,50"  
battiscopa  
**HOM051**

**8,5 mm**  
**40x80x5** . 15,75"x31,50"x1,97"  
gradino lineare M  
**HOM056**

**8,5 mm**  
**40x80x5** . 15,75"x31,50"x1,97"  
gradino angolare M  
**HOM061**

## CLAY

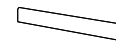

**6,5 mm**  
**8x120** . 3,15"x47,24"  
battiscopa  
**HOM037**

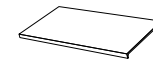

**6,5 mm**  
**33x120x5** . 12,99"x47,24"x1,97"  
gradino lineare LL  
**HOM042**

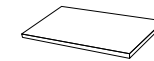

**6,5 mm**  
**33x120x5** . 12,99"x47,24"x1,97"  
gradino angolare LL  
**HOM047**

**8,5 mm**  
**8x80** . 3,15"x31,50"  
battiscopa  
**HOM052**

**8,5 mm**  
**40x80x5** . 15,75"x31,50"x1,97"  
gradino lineare M  
**HOM057**

**8,5 mm**  
**40x80x5** . 15,75"x31,50"x1,97"  
gradino angolare M  
**HOM062**

# homescape

62 HOMESCAPE\_CONCRETE EFFECT



## SIZES & SURFACES

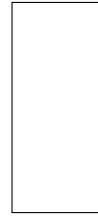

**120x278\***  
47,24"x109,45"



**120x120**  
47,24"x47,24"



**60x120**  
23,62"x47,24"



**80x80**  
31,50"x31,50"

**Natural**  
Rettificato | Rectified |  
Rectifié | Rektifiziert

**6,5 mm**

**120x278** . 47,24"x109,45"  
**HOM018**

**120x120** . 47,24"x47,24"  
**HOM008**

**8,5 mm**

**60x120** . 23,62"x47,24"  
**HOM089**

**80x80** . 31,50"x31,50"  
**HOM099**

## COAL

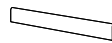

**6,5 mm**  
**8x120** . 3,15"x47,24"  
battiscopa  
**HOM038**



**6,5 mm**  
**33x120x5** . 12,99"x47,24"x1,97"  
gradino lineare LL  
**HOM043**



**6,5 mm**  
**33x120x5** . 12,99"x47,24"x1,97"  
gradino angolare LL  
**HOM048**

**8,5 mm**  
**8x80** . 3,15"x31,50"  
battiscopa  
**HOM053**

**8,5 mm**  
**40x80x5** . 15,75"x31,50"x1,97"  
gradino lineare M  
**HOM058**

**8,5 mm**  
**40x80x5** . 15,75"x31,50"x1,97"  
gradino angolare M  
**HOM063**



## HOMESCAPE TUB

**8,5 mm**  
**60x120** . 23,62"x47,24"  
decoro  
**HOM094**

**Suggested grout**  
113 . Cement Grey



## SIZES & SURFACES

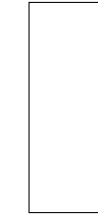

**120x278\***  
47,24"x109,45"



**120x120**  
47,24"x47,24"



**60x120**  
23,62"x47,24"



**80x80**  
31,50"x31,50"

**Natural**  
Rettificato | Rectified |  
Rectifié | Rektifiziert

**6,5 mm**

**120x278** . 47,24"x109,45"  
**HOM020**

**120x120** . 47,24"x47,24"  
**HOM010**

**8,5 mm**

**60x120** . 23,62"x47,24"  
**HOM091**

**80x80** . 31,50"x31,50"  
**HOM101**

## CARMEL

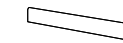

**6,5 mm**  
**8x120** . 3,15"x47,24"  
battiscopa  
**HOM040**

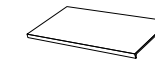

**6,5 mm**  
**33x120x5** . 12,99"x47,24"x1,97"  
gradino lineare LL  
**HOM045**

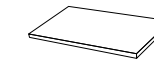

**6,5 mm**  
**33x120x5** . 12,99"x47,24"x1,97"  
gradino angolare LL  
**HOM050**

**8,5 mm**  
**8x80** . 3,15"x31,50"  
battiscopa  
**HOM055**

**8,5 mm**  
**40x80x5** . 15,75"x31,50"x1,97"  
gradino lineare M  
**HOM060**

**8,5 mm**  
**40x80x5** . 15,75"x31,50"x1,97"  
gradino angolare M  
**HOM065**



## HOMESCAPE TUB

**8,5 mm**  
**60x120** . 23,62"x47,24"  
decoro  
**HOM096**

**Suggested grout**  
134 . Silk



63 HOMESCAPE\_CONCRETE EFFECT



# homescape



## SIZES & SURFACES



**120x278\***  
47,24"x109,45"



**120x120**  
47,24"x47,24"



**60x120**  
23,62"x47,24"



**80x80**  
31,50"x31,50"

**Natural**  
Rettificato | Rectified |  
Rectifié | Rektifiziert

### 6,5 mm

**120x278** . 47,24"x109,45"  
**HOM019**

**120x120** . 47,24"x47,24"  
**HOM009**

### 8,5 mm

**60x120** . 23,62"x47,24"  
**HOM090**

**80x80** . 31,50"x31,50"  
**HOM100**

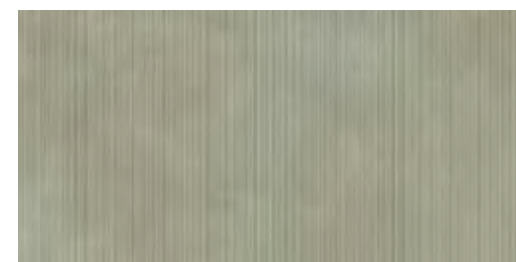

## MATCHA

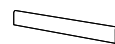

**6,5 mm**  
**8x120** . 3,15"x47,24"  
battiscopa  
**HOM039**

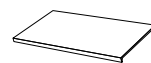

**6,5 mm**  
**33x120x5** . 12,99"x47,24"x1,97"  
gradino lineare LL  
**HOM044**

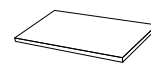

**6,5 mm**  
**33x120x5** . 12,99"x47,24"x1,97"  
gradino angolare LL  
**HOM049**

**8,5 mm**  
**8x80** . 3,15"x31,50"  
battiscopa  
**HOM054**

**8,5 mm**  
**40x80x5** . 15,75"x31,50"x1,97"  
gradino lineare M  
**HOM059**

**8,5 mm**  
**40x80x5** . 15,75"x31,50"x1,97"  
gradino angolare M  
**HOM064**

## HOMESCAPE TUB

**8,5 mm**  
**60x120** . 23,62"x47,24"  
decoro  
**HOM095**

**Suggested grout**  
110 . Manhattan 2000







# pigmento

Lastre / piastrelle di ceramica in gres porcellanato - Gruppo Bla UGL  
 Porcelain stoneware slabs / tiles - Gruppe Bla UGL  
 Dalles / carreaux en céramique en grès cérame - Group Bla UGL  
 Keramikplatten / keramikfliesen aus Feinsteinzeug - Gruppe Bla UGL



## THICKNESS



**2.OUT** 2 cm



**120x278\***  
47,24"x109,45"



**120x120**  
47,24"x47,24"



**60x120**  
23,62"x47,24"



**80x80**  
31,50"x31,50"



**40x80**  
15,75"x31,50"

## SURFACES

**Natural / Grip**  
 Rettificato | Rectified |  
 Rectifié | Rektifiziert

## TECH INFO

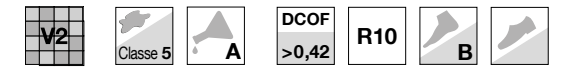

BS EN 16165\_C >  
 Dry & Wet rubber 4S: ≥ 36  
 AS 4586 > P3  
 UNE-ENV 12633 > Class 2

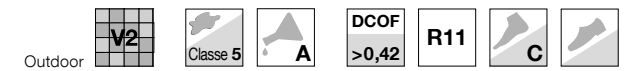

BS EN 16165\_C >  
 Dry & Wet rubber 4S: ≥ 36  
 AS 4586 > P3  
 UNE-ENV 12633 > Class 2

\* Lastre realizzate attraverso impasti colorati con colori standard | Slabs produced using coloured body mix available in standard shades  
 • Disponibile fino ad esaurimento scorte | Available while stocks last | Disponible jusqu'à épuisement des stocks | Verfügbar solange der Vorrat reicht

## COLORS



GESSO

FANGO

POLVERE

CARBONE

ORO

MATTONE

OSSIDO























# pigmento

78 PIGMENTO\_CONCRETE EFFECT



## SIZES & SURFACES



**120x278\***  
47,24"x109,45"



**120x120**  
47,24"x47,24"



**60x120**  
23,62"x47,24"



**80x80**  
31,50"x31,50"



**40x80**  
15,75"x31,50"

**Natural**  
Rettificato | Rectified |  
Rectifié | Rektifiziert

### 6,5 mm

**120x278** . 47,24"x109,45"  
**PGM029**

**120x120** . 47,24"x47,24"  
**PGM008**

**60x120** . 23,62"x47,24"  
**PGM015**

**Natural**  
Rettificato | Rectified |  
Rectifié | Rektifiziert

### 8,5 mm

**80x80** . 31,50"x31,50"  
**PGM202**

**40x80** . 17,75"x31,50"  
**PGM210**

**Grip**  
Rettificato | Rectified |  
Rectifié | Rektifiziert

### 2.OUT 2 cm

**Outdoor**  
**80x80** . 31,50"x31,50"  
**PGM132**

### 10 mm\*

**80x80** . 31,50"x31,50"  
**PGM036**

**40x80** . 17,75"x31,50"  
**PGM044**

## GESSO

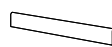

**6,5 mm PGM048**  
**8x120** . 3,15"x47,24"  
battiscopa



**6,5 mm PGM055**  
**33x120x5** . 12,99"x47,24"x1,97"  
gradino lineare LL



**6,5 mm PGM062**  
**33x120x5** . 12,99"x47,24"x1,97"  
gradino angolare LL

**8,5 mm PGM069A**  
**10 mm PGM069\***  
**8x80** . 3,15"x31,50"  
battiscopa

**8,5 mm PGM073A**  
**10 mm PGM073\***  
**40x80x5** . 15,75"x31,50"x1,97"  
gradino lineare M

**8,5 mm PGM077A**  
**10 mm PGM077\***  
**40x80x5** . 15,75"x31,50"x1,97"  
gradino angolare M

- Disponibile fino ad esaurimento scorte | Available while stocks last | Disponible jusqu'à épuisement des stocks | Verfügbar solange der Vorrat reicht

**Suggested grout**  
103 . Moon White



## SIZES & SURFACES



**120x278\***  
47,24"x109,45"



**120x120**  
47,24"x47,24"



**60x120**  
23,62"x47,24"



**80x80**  
31,50"x31,50"



**40x80**  
15,75"x31,50"

**Natural**  
Rettificato | Rectified |  
Rectifié | Rektifiziert

### 6,5 mm

**120x278** . 47,24"x109,45"  
**PGM030**

**120x120** . 47,24"x47,24"  
**PGM009**

**60x120** . 23,62"x47,24"  
**PGM016**

**Natural**  
Rettificato | Rectified |  
Rectifié | Rektifiziert

### 8,5 mm

**80x80** . 31,50"x31,50"  
**PGM204**

**40x80** . 17,75"x31,50"  
**PGM212**

**Grip**  
Rettificato | Rectified |  
Rectifié | Rektifiziert

### 2.OUT 2 cm

**Outdoor**  
**80x80** . 31,50"x31,50"  
**PGM131**

### 10 mm\*

**80x80** . 31,50"x31,50"  
**PGM037**

**40x80** . 17,75"x31,50"  
**PGM045**

## FANGO

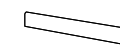

**6,5 mm PGM049**  
**8x120** . 3,15"x47,24"  
battiscopa

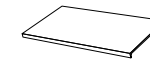

**6,5 mm PGM056**  
**33x120x5** . 12,99"x47,24"x1,97"  
gradino lineare LL

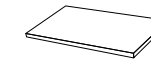

**6,5 mm PGM063**  
**33x120x5** . 12,99"x47,24"x1,97"  
gradino angolare LL

**8,5 mm PGM070A**  
**10 mm PGM070\***  
**8x80** . 3,15"x31,50"  
battiscopa

**8,5 mm PGM074A**  
**10 mm PGM074\***  
**40x80x5** . 15,75"x31,50"x1,97"  
gradino lineare M

**8,5 mm PGM078A**  
**10 mm PGM078\***  
**40x80x5** . 15,75"x31,50"x1,97"  
gradino angolare M

- Disponibile fino ad esaurimento scorte | Available while stocks last | Disponible jusqu'à épuisement des stocks | Verfügbar solange der Vorrat reicht

**Suggested grout**  
110 . Manhattan 2000



79 PIGMENTO\_CONCRETE EFFECT

# pigmento

80 PIGMENTO\_CONCRETE EFFECT



## SIZES & SURFACES



**120x278\***  
47,24"x109,45"



**120x120**  
47,24"x47,24"



**60x120**  
23,62"x47,24"



**80x80**  
31,50"x31,50"



**40x80**  
15,75"x31,50"

**Natural**  
Rettificato | Rectified |  
Rectifié | Rektifiziert

### 6,5 mm

**120x278** . 47,24"x109,45"  
**PGM031**

**120x120** . 47,24"x47,24"  
**PGM010**

**60x120** . 23,62"x47,24"  
**PGM017**

### 8,5 mm

**80x80** . 31,50"x31,50"  
**PGM203**

**40x80** . 17,75"x31,50"  
**PGM211**

**Grip**  
Rettificato | Rectified |  
Rectifié | Rektifiziert

## 2.OUT 2 cm

**Outdoor**  
**80x80** . 31,50"x31,50"  
**PGM133**

**Natural**  
Rettificato | Rectified |  
Rectifié | Rektifiziert

### 10 mm\*

**80x80** . 31,50"x31,50"  
**PGM038**

**40x80** . 17,75"x31,50"  
**PGM046**

## POLVERE

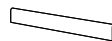

**6,5 mm PGM050**  
**8x120** . 3,15"x47,24"  
battiscopa



**6,5 mm PGM057**  
**33x120x5** . 12,99"x47,24"x1,97"  
gradino lineare LL



**6,5 mm PGM064**  
**33x120x5** . 12,99"x47,24"x1,97"  
gradino angolare LL

**8,5 mm PGM071A**  
**10 mm PGM071\***  
**8x80** . 3,15"x31,50"  
battiscopa

**8,5 mm PGM075A**  
**10 mm PGM075\***  
**40x80x5** . 15,75"x31,50"x1,97"  
gradino lineare M

**8,5 mm PGM079A**  
**10 mm PGM079\***  
**40x80x5** . 15,75"x31,50"x1,97"  
gradino angolare M

- Disponibile fino ad esaurimento scorte | Available while stocks last | Disponible jusqu'à épuisement des stocks | Verfügbar solange der Vorrat reicht

**Suggested grout**  
112 . Medium Grey



## SIZES & SURFACES

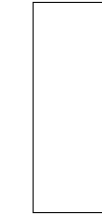

**120x278\***  
47,24"x109,45"

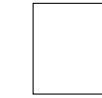

**120x120**  
47,24"x47,24"



**60x120**  
23,62"x47,24"



**80x80**  
31,50"x31,50"



**40x80**  
15,75"x31,50"

**Natural**  
Rettificato | Rectified |  
Rectifié | Rektifiziert

### 6,5 mm

**120x278** . 47,24"x109,45"  
**PGM032**

**120x120** . 47,24"x47,24"  
**PGM011**

**60x120** . 23,62"x47,24"  
**PGM018**

### 8,5 mm

**80x80** . 31,50"x31,50"  
**PGM205**

**40x80** . 17,75"x31,50"  
**PGM213**

**Natural**  
Rettificato | Rectified |  
Rectifié | Rektifiziert

### 10 mm\*

**80x80** . 31,50"x31,50"  
**PGM039**

**40x80** . 17,75"x31,50"  
**PGM047**

## CARBONE

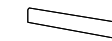

**6,5 mm PGM051**  
**8x120** . 3,15"x47,24"  
battiscopa



**6,5 mm PGM058**  
**33x120x5** . 12,99"x47,24"x1,97"  
gradino lineare LL

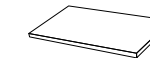

**6,5 mm PGM065**  
**33x120x5** . 12,99"x47,24"x1,97"  
gradino angolare LL

**8,5 mm PGM072A**  
**10 mm PGM072\***  
**8x80** . 3,15"x31,50"  
battiscopa

**8,5 mm PGM076A**  
**10 mm PGM076\***  
**40x80x5** . 15,75"x31,50"x1,97"  
gradino lineare M

**8,5 mm PGM080A**  
**10 mm PGM080\***  
**40x80x5** . 15,75"x31,50"x1,97"  
gradino angolare M

- Disponibile fino ad esaurimento scorte | Available while stocks last | Disponible jusqu'à épuisement des stocks | Verfügbar solange der Vorrat reicht

**Suggested grout**  
119 . London Grey



81 PIGMENTO\_CONCRETE EFFECT

# pigmento

82 PIGMENTO\_CONCRETE EFFECT



## SIZES & SURFACES

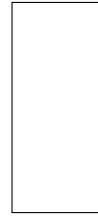

**120x278\***  
47,24"x109,45"



**120x120**  
47,24"x47,24"



**60x120**  
23,62"x47,24"

**Natural**  
Rettificato | Rectified |  
Rectifié | Rektifiziert

**6,5 mm**

**120x278** . 47,24"x109,45"  
**PGM035**

**120x120** . 47,24"x47,24"  
**PGM014**

**60x120** . 23,62"x47,24"  
**PGM021**

ORO

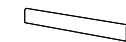

**6,5 mm**  
**8x120** . 3,15"x47,24"  
battiscopa  
**PGM054**



**6,5 mm**  
**33x120x5** . 12,99"x47,24"x1,97"  
gradino lineare LL  
**PGM061**



**6,5 mm**  
**33x120x5** . 12,99"x47,24"x1,97"  
gradino angolare LL  
**PGM068**

**Suggested grout**  
138 . Almond



## SIZES & SURFACES



**120x278\***  
47,24"x109,45"



**120x120**  
47,24"x47,24"



**60x120**  
23,62"x47,24"

**Natural**  
Rettificato | Rectified |  
Rectifié | Rektifiziert

**6,5 mm**

**120x278** . 47,24"x109,45"  
**PGM034**

**120x120** . 47,24"x47,24"  
**PGM013**

**60x120** . 23,62"x47,24"  
**PGM020**

MATTONE

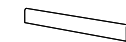

**6,5 mm**  
**8x120** . 3,15"x47,24"  
battiscopa  
**PGM053**

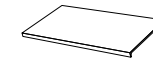

**6,5 mm**  
**33x120x5** . 12,99"x47,24"x1,97"  
gradino lineare LL  
**PGM060**

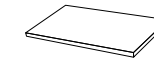

**6,5 mm**  
**33x120x5** . 12,99"x47,24"x1,97"  
gradino angolare LL  
**PGM067**

**Suggested grout**  
142 . Brown



83 PIGMENTO\_CONCRETE EFFECT



# pigmento



OSSIDO

## SIZES & SURFACES



120x278\*  
47,24"x109,45"



120x120  
47,24"x47,24"



60x120  
23,62"x47,24"

**Natural**  
Rettificato | Rectified |  
Rectifié | Rektifiziert

**6,5 mm**

120x278 . 47,24"x109,45"  
**PGM033**

120x120 . 47,24"x47,24"  
**PGM012**

60x120 . 23,62"x47,24"  
**PGM019**

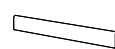

**6,5 mm**  
8x120 . 3,15"x47,24"  
battiscopa  
**PGM052**



**6,5 mm**  
33x120x5 . 12,99"x47,24"x1,97"  
gradino lineare LL  
**PGM059**



**6,5 mm**  
33x120x5 . 12,99"x47,24"x1,97"  
gradino angolare LL  
**PGM066**

**Suggested grout**  
174 . Tornado



# pezzi speciali

Special trims | Pièces spéciales | Formteile

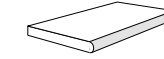

**2 cm**  
40x80x2 . 15,75"x31,50"x0,78"  
gradone toro lineare  
**PGM153** Gesso  
**PGM134** Fango  
**PGM173** Polvere

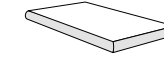

**2 cm**  
40x80x2 . 15,75"x31,50"x0,78"  
gradone toro angolare dx  
**PGM154** Gesso  
**PGM135** Fango  
**PGM174** Polvere

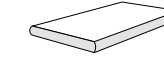

**2 cm**  
40x80x2 . 15,75"x31,50"x0,78"  
gradone toro angolare sx  
**PGM155** Gesso  
**PGM136** Fango  
**PGM175** Polvere

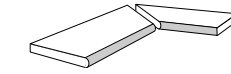

**2 cm**  
40x80x2 . 15,75"x31,50"x0,78"  
comp. gradone toro ang. interno  
**PGM156** Gesso  
**PGM137** Fango  
**PGM176** Polvere

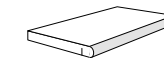

**2 cm**  
40x80x2 . 15,75"x31,50"x0,78"  
gradone toro lineare nodrip  
**PGM157** Gesso  
**PGM138** Fango  
**PGM177** Polvere

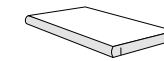

**2 cm**  
40x80x2 . 15,75"x31,50"x0,78"  
gradone toro angolare dx nodrip  
**PGM158** Gesso  
**PGM139** Fango  
**PGM178** Polvere

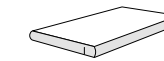

**2 cm**  
40x80x2 . 15,75"x31,50"x0,78"  
gradone toro angolare sx nodrip  
**PGM159** Gesso  
**PGM140** Fango  
**PGM179** Polvere

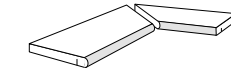

**2 cm**  
40x80x2 . 15,75"x31,50"x0,78"  
comp. gradone toro ang. interno nodrip  
**PGM160** Gesso  
**PGM141** Fango  
**PGM180** Polvere

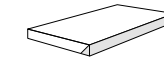

**2 cm**  
40x80x2 . 15,75"x31,50"x0,78"  
gradone cover lineare  
**PGM164** Gesso  
**PGM145** Fango  
**PGM184** Polvere

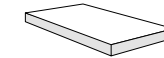

**2 cm**  
40x80x2 . 15,75"x31,50"x0,78"  
gradone cover angolare dx  
**PGM166** Gesso  
**PGM146** Fango  
**PGM185** Polvere

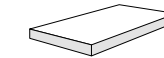

**2 cm**  
40x80x2 . 15,75"x31,50"x0,78"  
gradone cover angolare sx  
**PGM167** Gesso  
**PGM147** Fango  
**PGM186** Polvere

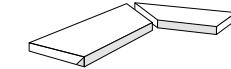

**2 cm**  
40x80x2 . 15,75"x31,50"x0,78"  
comp. gradone cover ang. interno  
**PGM168** Gesso  
**PGM148** Fango  
**PGM187** Polvere

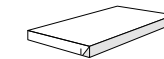

**2 cm**  
40x80x2 . 15,75"x31,50"x0,78"  
gradone cover lineare nodrip  
**PGM169** Gesso  
**PGM149** Fango  
**PGM188** Polvere

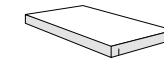

**2 cm**  
40x80x2 . 15,75"x31,50"x0,78"  
gradone cover angolare dx nodrip  
**PGM170** Gesso  
**PGM150** Fango  
**PGM189** Polvere

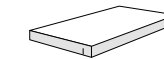

**2 cm**  
40x80x2 . 15,75"x31,50"x0,78"  
gradone cover angolare sx nodrip  
**PGM171** Gesso  
**PGM151** Fango  
**PGM190** Polvere

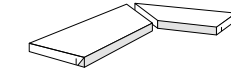

**2 cm**  
40x80x2 . 15,75"x31,50"x0,78"  
comp. gradone cover ang. interno nodrip  
**PGM172** Gesso  
**PGM152** Fango  
**PGM191** Polvere

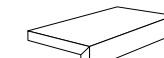

**2 cm**  
40x80x5 . 15,75"x31,50"x1,97"  
elemento L lineare  
**PGM161** Gesso  
**PGM142** Fango  
**PGM181** Polvere

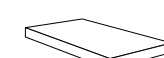

**2 cm**  
40x80x5 . 15,75"x31,50"x1,97"  
elemento L angolare dx  
**PGM162** Gesso  
**PGM143** Fango  
**PGM182** Polvere

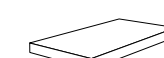

**2 cm**  
40x80x5 . 15,75"x31,50"x1,97"  
elemento L angolare sx  
**PGM163** Gesso  
**PGM144** Fango  
**PGM183** Polvere



# urban craft

Lastre di ceramica in gres porcellanato - Gruppo Bla UGL  
 Porcelain stoneware slabs - Gruppe Bla UGL  
 Dalles en céramique en grès cérame - Group Bla UGL  
 Keramikplatten aus Feinsteinzeug - Gruppe Bla UGL



## THICKNESS



6,5 mm  
SELF LEVELING

**2.OUT** 2 cm

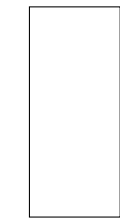

120x278\*  
47,24"x109,45"

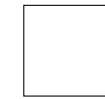

120x120  
47,24"x47,24"



60x120  
23,62"x47,24"



100x100  
39,37"x39,37"

## SURFACES

Natural / Grip  
 Rettificato | Rectified |  
 Rectifié | Rektifiziertw

## TECH INFO



BS EN 16165\_C >  
 Dry & Wet rubber 4S: ≥ 36  
 AS 4586 > P3  
 UNE-ENV 12633 > Class 2

Outdoor



BS EN 16165\_C >  
 Dry & Wet rubber 4S: ≥ 36  
 AS 4586 > P3  
 UNE-ENV 12633 > Class 2

\* Lastre realizzate attraverso impasti colorati con colori standard | Slabs produced using coloured body mix available in standard shades

## COLORS



PLASTER



REDCLAY



CHARCOAL

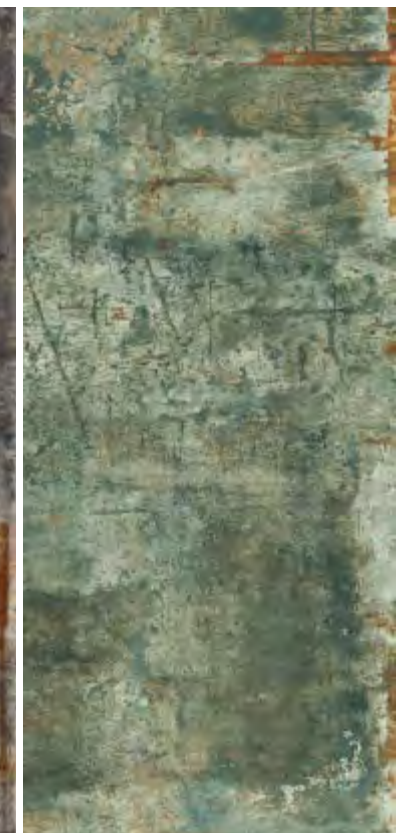

CHROME















# urban craft

REGISTERED DESIGN



SIZES & SURFACES



**120x278\***  
47,24"x109,45"



**120x120**  
47,24"x47,24"



**60x120**  
23,62"x47,24"



**100x100**  
39,37"x39,37"

**Natural**  
Rettificato | Rectified |  
Rectifi | Rektifiziert

**6,5 mm**

**120x278** . 47,24"x109,45"  
**UBC007**

**120x120** . 47,24"x47,24"  
**UBC010**

**60x120** . 23,62"x47,24"  
**UBC037**

**Grip**  
Rettificato | Rectified |  
Rectifié | Rektifiziert

**2.OUT 2 cm**

**Outdoor**  
**100x100** . 39,37"x39,37"  
**UBC058**



SIZES & SURFACES



**120x278\***  
47,24"x109,45"



**120x120**  
47,24"x47,24"



**60x120**  
23,62"x47,24"

**Natural**  
Rettificato | Rectified |  
Rectifi | Rektifiziert

**6,5 mm**

**120x278** . 47,24"x109,45"  
**UBC009**

**120x120** . 47,24"x47,24"  
**UBC012**

**60x120** . 23,62"x47,24"  
**UBC039**

94 URBAN CRAFT\_ CONCRETE EFFECT

95 URBAN CRAFT\_ CONCRETE EFFECT

PLASTER

REDCLAY

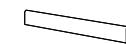

**6,5 mm**  
**8x120** . 3,15"x47,24"  
battiscopa  
**UBC013**



**6,5 mm**  
**33x120x5** . 12,99"x47,24"x1,97"  
gradino lineare LL  
**UBC016**



**6,5 mm**  
**33x120x5** . 12,99"x47,24"x1,97"  
gradino angolare LL  
**UBC019**

**Suggested grout**  
111 . Silver Grey

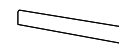

**6,5 mm**  
**8x120** . 3,15"x47,24"  
battiscopa  
**UBC015**

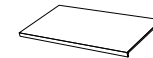

**6,5 mm**  
**33x120x5** . 12,99"x47,24"x1,97"  
gradino lineare LL  
**UBC018**

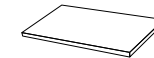

**6,5 mm**  
**33x120x5** . 12,99"x47,24"x1,97"  
gradino angolare LL  
**UBC021**

**Suggested grout**  
135 . Golden Dust





# urban craft

REGISTERED DESIGN

96 URBAN CRAFT\_ CONCRETE EFFECT



SIZES & SURFACES

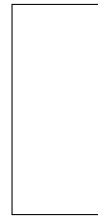

**120x278\***  
47,24"x109,45"



**120x120**  
47,24"x47,24"



**60x120**  
23,62"x47,24"

**Natural**  
Rettificato | Rectified |  
Rectifi | Rektifiziert

**6,5 mm**

**120x278** . 47,24"x109,45"  
**UBC008**

**120x120** . 47,24"x47,24"  
**UBC011**

**60x120** . 23,62"x47,24"  
**UBC038**

CHARCOAL



SIZES & SURFACES



**120x278\***  
47,24"x109,45"



**120x120**  
47,24"x47,24"



**60x120**  
23,62"x47,24"

**Natural**  
Rettificato | Rectified |  
Rectifi | Rektifiziert

**6,5 mm**

**120x278** . 47,24"x109,45"  
**UBC044**

**120x120** . 47,24"x47,24"  
**UBC041**

**60x120** . 23,62"x47,24"  
**UBC042**

CHROME

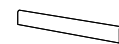

**6,5 mm**  
**8x120** . 3,15"x47,24"  
battiscopa  
**UBC014**



**6,5 mm**  
**33x120x5** . 12,99"x47,24"x1,97"  
gradino lineare LL  
**UBC017**



**6,5 mm**  
**33x120x5** . 12,99"x47,24"x1,97"  
gradino angolare LL  
**UBC020**

**Suggested grout**  
113 . Cement Grey

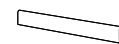

**6,5 mm**  
**8x120** . 3,15"x47,24"  
battiscopa  
**UBC045**

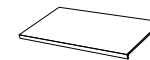

**6,5 mm**  
**33x120x5** . 12,99"x47,24"x1,97"  
gradino lineare LL  
**UBC046**



**6,5 mm**  
**33x120x5** . 12,99"x47,24"x1,97"  
gradino angolare LL  
**UBC047**

**Suggested grout**  
115 . River Grey



97 URBAN CRAFT\_ CONCRETE EFFECT



# pezzi speciali

Special trims | Pièces spéciales | Formteile

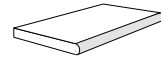

**2 cm**  
**40x100x2** . 15,75"x39,37"x0,78"  
gradone toro lineare  
**UBC059** Plaster

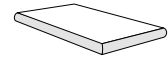

**2 cm**  
**40x100x2** . 15,75"x39,37"x0,78"  
gradone toro angolare dx  
**UBC060** Plaster

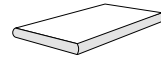

**2 cm**  
**40x100x2** . 15,75"x39,37"x0,78"  
gradone toro angolare sx  
**UBC061** Plaster

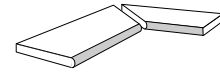

**2 cm**  
**40x100x2** . 15,75"x39,37"x0,78"  
comp. gradone toro ang. interno  
**UBC062** Plaster

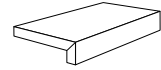

**2 cm**  
**40x100x5** . 15,75"x39,37"x1,97"  
elemento L lineare  
**UBC063** Plaster

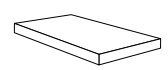

**2 cm**  
**40x100x5** . 15,75"x39,37"x1,97"  
elemento L angolare dx  
**UBC064** Plaster

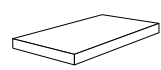

**2 cm**  
**40x100x5** . 15,75"x39,37"x1,97"  
elemento L angolare sx  
**UBC065** Plaster

## 2.0UT







# portland

Lastre / piastrelle di ceramica in gres porcellanato - Gruppo Bla UGL  
 Porcelain stoneware slabs / tiles - Gruppe Bla UGL  
 Dalles / carreaux en céramique en grès cérame - Group Bla UGL  
 Keramikplatten / keramikfliesen aus Feinsteinzeug - Gruppe Bla UGL

## THICKNESS

**6,5 mm** **8,5 mm**  
 SELF LEVELING **10 mm**•

**2.OUT** 2 cm

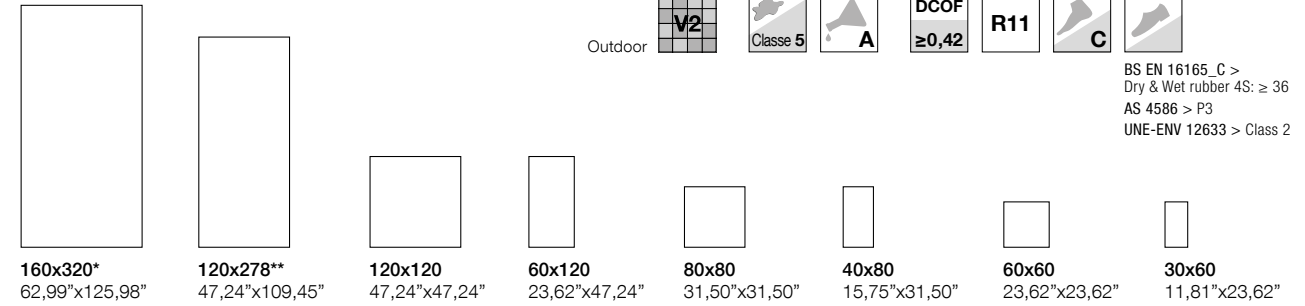

\* Lastre realizzate attraverso impasti tecnici colorati con colori dedicati | Slabs produced using coloured body mix with technical features available in dedicated shades  
 \*\* Lastre realizzate attraverso impasti colorati con colori standard | Slabs produced using coloured body mix available in standard shades  
 • Disponibile fino ad esaurimento scorte | Available while stocks last | Disponible jusqu'à épuisement des stocks | Verfügbar solange der Vorrat reicht

Materiali ceramici prodotti con differenti tecnologie, con risultati estetici differenziati che non consentono la miscelazione tra i diversi spessori | Ceramics manufactured using a range of technologies, with different effects, which do not allow materials with different thicknesses to be used together

## SURFACES

**Natural / Grip**  
 Rettificato | Rectified |  
 Rectifié | Rektifiziert

## TECH INFO

BS EN 16165\_C >  
 Dry & Wet rubber 4S: ≥ 36  
 AS 4586 > P3  
 UNE-ENV 12633 > Class 2

Outdoor

BS EN 16165\_C >  
 Dry & Wet rubber 4S: ≥ 36  
 AS 4586 > P3  
 UNE-ENV 12633 > Class 2

## COLORS



JORDAN

HOOD

TABOR

HELEN

LASSEN









104 PORTLAND\_CONCRETE EFFECT

JORDAN



105 PORTLAND\_CONCRETE EFFECT

TABOR MOOD





106 PORTLAND CONCRETE EFFECT

107 PORTLAND CONCRETE EFFECT







# portland

110 PORTLAND\_CONCRETE EFFECT



## SIZES & SURFACES

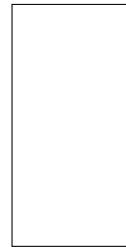

**160x320\***  
62,99"x125,98"



**120x278\*\***  
47,24"x109,45"



**120x120**  
47,24"x47,24"



**60x120**  
23,62"x47,24"



**80x80**  
31,50"x31,50"



**40x80**  
15,75"x31,50"

**Natural**  
Rettificato | Rectified |  
Rectifié | Rektifiziert

### 6,5 mm

- **160x320** . 62,99"x125,98"  
**PTL099**

**120x278** . 47,24"x109,45"  
**PTL215**

**120x120** . 47,24"x47,24"  
**PTL057**

**60x120** . 23,62"x47,24"  
**PTL170**

### 8,5 mm

**60x120** . 23,62"x47,24"  
**PTL368**

**80x80** . 31,50"x31,50"  
**PTL372**

**40x80** . 15,75"x31,50"  
**PTL384**

**Grip**  
Rettificato | Rectified |  
Rectifié | Rektifiziert

## 2.OUT 2 cm

**Outdoor**  
**80x80** . 31,50"x31,50"  
**PTL299**

Per pose multiformato e con decorazioni si prega di richiedere abbinamenti in fase di ordine | If your design includes different-sized tiles and/or decorative tiles, please specify the combinations required when placing your order | Pour les poses multiformat et avec des décorations, veuillez demander les associations à la commande | Bei Mehrformatverlegungen und mit Dekorationen bitten wir Sie, bei Bestellung die Kombinationen anzufagen

**Natural**  
Rettificato | Rectified |  
Rectifié | Rektifiziert

### 10 mm\*\*

**60x120** . 23,62"x47,24"  
**PTL110**

**80x80** . 31,50"x31,50"  
**PTL117**

**40x80** . 15,75"x31,50"  
**PTL118**

## LAYING EXAMPLE



111 PORTLAND\_CONCRETE EFFECT

## JORDAN

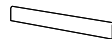

**6,5 mm PTL111**  
**8x120** . 3,15"x47,24"  
battiscopa



**6,5 mm PTL112**  
**33x120x5** . 12,99"x47,24"x1,97"  
gradino lineare LL



**6,5 mm PTL113**  
**33x120x5** . 12,99"x47,24"x1,97"  
gradino angolare LL

**8,5 mm PTL143A**  
**10 mm PTL143\*\***  
**8x80** . 3,15"x31,50"  
battiscopa

• Disponibile su richiesta | Available on request | Disponible sur demande | Auf Anfrage erhältlich

•• Disponibile fino ad esaurimento scorte | Available while stocks last | Disponible jusqu'à épuisement des stocks | Verfügbar solange der Vorrat reicht

### Suggested grout

130 . Jasmine





# portland



112 PORTLAND\_CONCRETE EFFECT

## SIZES & SURFACES



**160x320\***  
62,99"x125,98"



**120x278\*\***  
47,24"x109,45"



**120x120**  
47,24"x47,24"



**60x120**  
23,62"x47,24"



**80x80**  
31,50"x31,50"



**40x80**  
15,75"x31,50"



**60x60**  
23,62"x23,62"



**30x60**  
11,81"x23,62"

## HOOD

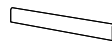

**6,5 mm PTL008**  
8x120 . 3,15"x47,24"  
battiscopa



**6,5 mm PTL006**  
33x120x5 . 12,99"x47,24"x1,97"  
gradino lineare LL



**6,5 mm PTL007**  
33x120x5 . 12,99"x47,24"x1,97"  
gradino angolare LL

**8,5 mm PTL275A**  
10 mm PTL275\*\*  
8x80 . 3,15"x31,50"  
battiscopa

**8,5 mm PTL283A**  
10 mm PTL283\*\*  
40x80x5 . 15,75"x31,50"x1,97"  
gradino lineare M

**8,5 mm PTL287A**  
10 mm PTL287\*\*  
40x80x5 . 15,75"x31,50"x1,97"  
gradino angolare M

**8,5 mm PTL279A**  
10 mm PTL279\*\*  
8x60 . 3,15"x23,62"  
battiscopa

**Natural**  
Rettificato | Rectified |  
Rectifié | Rektifiziert

### 6,5 mm

• **160x320** . 62,99"x125,98"  
**PTL091**

**120x278** . 47,24"x109,45"  
**PTL216**

**120x120** . 47,24"x47,24"  
**PTL004**

**60x120** . 23,62"x47,24"  
**PTL169**

### 8,5 mm

**60x120** . 23,62"x47,24"  
**PTL367**

**80x80** . 31,50"x31,50"  
**PTL371**

**40x80** . 15,75"x31,50"  
**PTL383**

**60x60** . 23,62"x23,62"  
**PTL388**

**30x60** . 11,81"x23,62"  
**PTL396**

**Grip**  
Rettificato | Rectified |  
Rectifié | Rektifiziert

## 2.OUT 2 cm

**Outdoor**  
**80x80** . 31,50"x31,50"  
**PTL298**

Per pose multiformato e con decorazioni si prega di richiedere abbinamenti in fase di ordine | If your design includes different-sized tiles and/or decorative tiles, please specify the combinations required when placing your order | Pour les poses multiformat et avec des décorations, veuillez demander les associations à la commande | Bei Mehrformatverlegungen und mit Dekorationen bitten wir Sie, bei Bestellung die Kombinationen anzufagen

**Natural**  
Rettificato | Rectified |  
Rectifié | Rektifiziert

### 10 mm\*\*

**60x120** . 23,62"x47,24"  
**PTL104**

**80x80** . 31,50"x31,50"  
**PTL206**

**40x80** . 15,75"x31,50"  
**PTL198**

**60x60** . 23,62"x23,62"  
**PTL179**

**30x60** . 11,81"x23,62"  
**PTL180**

• Disponibile su richiesta | Available on request | Disponible sur demande | Auf Anfrage erhältlich

•• Disponibile fino ad esaurimento scorte | Available while stocks last | Disponible jusqu'à épuisement des stocks | Verfügbar solange der Vorrat reicht

**Suggested grout**  
110 . Manhattan 2000



## LAYING EXAMPLE



113 PORTLAND\_CONCRETE EFFECT



# portland

114 PORTLAND\_CONCRETE EFFECT



## HOOD DECORATO

8,5 mm PTL376  
10 mm PTL202\*\*  
80x80 . 31,50"x31,50"

8,5 mm PTL392  
10 mm PTL178\*\*  
60x60 . 23,62"x23,62"



## HOOD MOOD

6,5 mm PTL034  
120x120 . 47,24"x47,24"  
decoro



8,5 mm PTL400  
10 mm PTL267\*\*  
30x60 . 11,81"x23,62"  
mix size



8,5 mm PTL271A  
10 mm PTL271\*\*  
30x30 . 11,81"x11,81"  
mosaico (36 pcs)

115 PORTLAND\_CONCRETE EFFECT

\*\* Disponibile fino ad esaurimento scorte | Available while stocks last |  
Disponibile jusqu'à épuisement des stocks | Verfügbar solange der  
Vorrat reicht



# portland



116 PORTLAND\_CONCRETE EFFECT

## SIZES & SURFACES



**160x320\***  
62,99"x125,98"

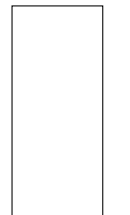

**120x278\*\***  
47,24"x109,45"



**120x120**  
47,24"x47,24"

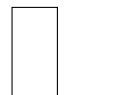

**60x120**  
23,62"x47,24"



**80x80**  
31,50"x31,50"



**40x80**  
15,75"x31,50"



**60x60**  
23,62"x23,62"



**30x60**  
11,81"x23,62"

## TABOR

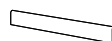

**6,5 mm PTL016**  
8x120 . 3,15"x47,24"  
battiscopa



**6,5 mm PTL014**  
33x120x5 . 12,99"x47,24"x1,97"  
gradino lineare LL



**6,5 mm PTL015**  
33x120x5 . 12,99"x47,24"x1,97"  
gradino angolare LL

**8,5 mm PTL277A**  
10 mm PTL277\*\*  
8x80 . 3,15"x31,50"  
battiscopa

**8,5 mm PTL285A**  
10 mm PTL285\*\*  
40x80x5 . 15,75"x31,50"x1,97"  
gradino lineare M

**8,5 mm PTL289A**  
10 mm PTL289\*\*  
40x80x5 . 15,75"x31,50"x1,97"  
gradino angolare M

**8,5 mm PTL281A**  
10 mm PTL281\*\*  
8x60 . 3,15"x23,62"  
battiscopa

**Natural**  
Rettificato | Rectified |  
Rectifié | Rektifiziert

### 6,5 mm

• **160x320** . 62,99"x125,98"  
**PTL095**

**120x278** . 47,24"x109,45"  
**PTL217**

**120x120** . 47,24"x47,24"  
**PTL012**

**60x120** . 23,62"x47,24"  
**PTL171**

### 8,5 mm

**60x120** . 23,62"x47,24"  
**PTL369**

**80x80** . 31,50"x31,50"  
**PTL374**

**40x80** . 15,75"x31,50"  
**PTL386**

**60x60** . 23,62"x23,62"  
**PTL390**

**30x60** . 11,81"x23,62"  
**PTL398**

Per pose multiformato e con decorazioni si prega di richiedere abbinamenti in fase di ordine | If your design includes different-sized tiles and/or decorative tiles, please specify the combinations required when placing your order | Pour les poses multiformat et avec des décorations, veuillez demander les associations à la commande | Bei Mehrformatverlegungen und mit Dekorationen bitten wir Sie, bei Bestellung die Kombinationen anzufagen

**Natural**  
Rettificato | Rectified |  
Rectifié | Rektifiziert

### 10 mm\*\*

**60x120** . 23,62"x47,24"  
**PTL107**

**80x80** . 31,50"x31,50"  
**PTL208**

**40x80** . 15,75"x31,50"  
**PTL200**

**60x60** . 23,62"x23,62"  
**PTL185**

**30x60** . 11,81"x23,62"  
**PTL193**

• Disponibile su richiesta | Available on request | Disponible sur demande | Auf Anfrage erhältlich

•• Disponibile fino ad esaurimento scorte | Available while stocks last | Disponible jusqu'à épuisement des stocks | Verfügbar solange der Vorrat reicht

**Suggested grout**  
119 . London Grey



## LAYING EXAMPLE



117 PORTLAND\_CONCRETE EFFECT



# portland

118 PORTLAND\_CONCRETE EFFECT



## TABOR DECORATO

8,5 mm PTL378  
10 mm PTL204\*\*  
80x80 . 31,50"x31,50"

8,5 mm PTL394  
10 mm PTL186\*\*  
60x60 . 23,62"x23,62"



## TABOR MOOD

6,5 mm PTL036  
120x120 . 47,24"x47,24"  
decoro



8,5 mm PTL402  
10 mm PTL269\*\*  
30x60 . 11,81"x23,62"  
mix size

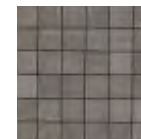

8,5 mm PTL273A  
10 mm PTL273\*\*  
30x30 . 11,81"x11,81"  
mosaico (36 pcs)

119 PORTLAND\_CONCRETE EFFECT

\*\* Disponibile fino ad esaurimento scorte | Available while stocks last |  
Disponibile jusqu'à épuisement des stocks | Verfügbar solange der  
Vorrat reicht



# portland

120 PORTLAND\_CONCRETE EFFECT



## SIZES & SURFACES



**120x278\*\***  
47,24"x109,45"



**120x120**  
47,24"x47,24"



**60x120**  
23,62"x47,24"



**80x80**  
31,50"x31,50"



**40x80**  
15,75"x31,50"



**60x60**  
23,62"x23,62"



**30x60**  
11,81"x23,62"

**Natural**  
Rettificato | Rectified |  
Rectifié | Rektifiziert

### 6,5 mm

**120x278** . 47,24"x109,45"  
**PTL218**

**120x120** . 47,24"x47,24"  
**PTL020**

**60x120** . 23,62"x47,24"  
**PTL172**

### 8,5 mm

**80x80** . 31,50"x31,50"  
**PTL370**

**40x80** . 15,75"x31,50"  
**PTL382**

**60x60** . 23,62"x23,62"  
**PTL387**

**30x60** . 11,81"x23,62"  
**PTL395**

Per pose multiformato e con decorazioni si prega di richiedere abbinamenti in fase di ordine | If your design includes different-sized tiles and/or decorative tiles, please specify the combinations required when placing your order | Pour les poses multiformat et avec des décorations, veuillez demander les associations à la commande | Bei Mehrformatverlegungen und mit Dekorationen bitten wir Sie, bei Bestellung die Kombinationen anzufagen

**Natural**  
Rettificato | Rectified |  
Rectifié | Rektifiziert

### 10 mm\*\*

**80x80** . 31,50"x31,50"  
**PTL205**

**40x80** . 15,75"x31,50"  
**PTL197**

**60x60** . 23,62"x23,62"  
**PTL181**

**30x60** . 11,81"x23,62"  
**PTL191**

## LAYING EXAMPLE



121 PORTLAND\_CONCRETE EFFECT

## HELEN

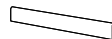

**6,5 mm PTL024**  
**8x120** . 3,15"x47,24"  
battiscopa



**6,5 mm PTL022**  
**33x120x5** . 12,99"x47,24"x1,97"  
gradino lineare LL



**6,5 mm PTL023**  
**33x120x5** . 12,99"x47,24"x1,97"  
gradino angolare LL

**8,5 mm PTL274A**  
**10 mm PTL274\*\***  
**8x80** . 3,15"x31,50"  
battiscopa

**8,5 mm PTL282A**  
**10 mm PTL282\*\***  
**40x80x5** . 15,75"x31,50"x1,97"  
gradino lineare M

**8,5 mm PTL286A**  
**10 mm PTL286\*\***  
**40x80x5** . 15,75"x31,50"x1,97"  
gradino angolare M

**8,5 mm PTL278A**  
**10 mm PTL278\*\***  
**8x60** . 3,15"x23,62"  
battiscopa

\*\* Disponibile fino ad esaurimento scorte | Available while stocks last |  
Disponibile jusqu'à épuisement des stocks | Verfügbar solange der  
Vorrat reicht

**Suggested grout**  
132 . Beige 2000





# portland

122 PORTLAND\_CONCRETE EFFECT



## HELEN DECORATO

**8,5 mm PTL375**  
**10 mm PTL201\*\***  
80x80 . 31,50"x31,50"

**8,5 mm PTL391**  
**10 mm PTL182\*\***  
60x60 . 23,62"x23,62"

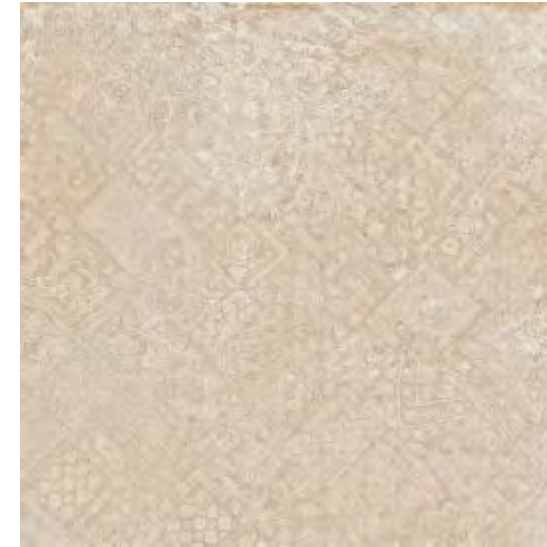

## HELEN MOOD

**6,5 mm PTL038**  
120x120 . 47,24"x47,24"  
decoro

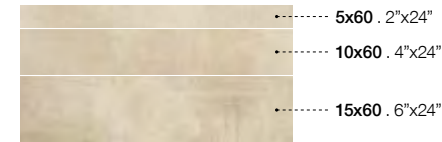

**8,5 mm PTL399**  
**10 mm PTL266\*\***  
30x60 . 11,81"x23,62"  
mix size



**8,5 mm PTL270A**  
**10 mm PTL270\*\***  
30x30 . 11,81"x11,81"  
mosaico (36 pcs)

123 PORTLAND\_CONCRETE EFFECT

\*\* Disponibile fino ad esaurimento scorte | Available while stocks last |  
Disponibile jusqu'à épuisement des stocks | Verfügbar solange der  
Vorrat reicht



# portland

124 PORTLAND\_CONCRETE EFFECT



## SIZES & SURFACES



**120x278\*\***  
47,24"x109,45"



**120x120**  
47,24"x47,24"



**60x120**  
23,62"x47,24"



**80x80**  
31,50"x31,50"



**40x80**  
15,75"x31,50"



**60x60**  
23,62"x23,62"



**30x60**  
11,81"x23,62"

**Natural**  
Rettificato | Rectified |  
Rectifié | Rektifiziert

### 6,5 mm

**120x278** . 47,24"x109,45"  
**PTL219**

**120x120** . 47,24"x47,24"  
**PTL028**

**60x120** . 23,62"x47,24"  
**PTL173**

### 8,5 mm

**80x80** . 31,50"x31,50"  
**PTL373**

**40x80** . 15,75"x31,50"  
**PTL385**

**60x60** . 23,62"x23,62"  
**PTL389**

**30x60** . 11,81"x23,62"  
**PTL397**

**Grip**  
Rettificato | Rectified |  
Rectifié | Rektifiziert

## 2.OUT 2 cm

**Outdoor**  
**80x80** . 31,50"x31,50"  
**PTL300**

Per pose multiformato e con decorazioni si prega di richiedere abbinamenti in fase di ordine | If your design includes different-sized tiles and/or decorative tiles, please specify the combinations required when placing your order | Pour les poses multiformat et avec des décorations, veuillez demander les associations à la commande | Bei Mehrformatverlegungen und mit Dekorationen bitten wir Sie, bei Bestellung die Kombinationen anzufagen

**Natural**  
Rettificato | Rectified |  
Rectifié | Rektifiziert

### 10 mm\*\*

**80x80** . 31,50"x31,50"  
**PTL207**

**40x80** . 15,75"x31,50"  
**PTL199**

**60x60** . 23,62"x23,62"  
**PTL183**

**30x60** . 11,81"x23,62"  
**PTL192**

## LAYING EXAMPLE



125 PORTLAND\_CONCRETE EFFECT

## LASSEN

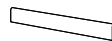

**6,5 mm PTL032**  
**8x120** . 3,15"x47,24"  
battiscopa



**6,5 mm PTL030**  
**33x120x5** . 12,99"x47,24"x1,97"  
gradino lineare LL



**6,5 mm PTL031**  
**33x120x5** . 12,99"x47,24"x1,97"  
gradino angolare LL

**8,5 mm PTL276A**  
**10 mm PTL276\*\***  
**8x80** . 3,15"x31,50"  
battiscopa

**8,5 mm PTL284A**  
**10 mm PTL284\*\***  
**40x80x5** . 15,75"x31,50"x1,97"  
gradino lineare M

**8,5 mm PTL288A**  
**10 mm PTL288\*\***  
**40x80x5** . 15,75"x31,50"x1,97"  
gradino angolare M

**8,5 mm PTL280A**  
**10 mm PTL280\*\***  
**8x60** . 3,15"x23,62"  
battiscopa

\*\* Disponibile fino ad esaurimento scorte | Available while stocks last |  
Disponibile jusqu'à épuisement des stocks | Verfügbar solange der  
Vorrat reicht

**Suggested grout**

134 . Silk





# portland

126 PORTLAND\_CONCRETE EFFECT



## LASSEN DECORATO

8,5 mm PTL377  
10 mm PTL203\*\*  
80x80 . 31,50"x31,50"

8,5 mm PTL393  
10 mm PTL184\*\*  
60x60 . 23,62"x23,62"



## LASSEN MOOD

6,5 mm PTL040  
120x120 . 47,24"x47,24"  
decoro



8,5 mm PTL401  
10 mm PTL268\*\*  
30x60 . 11,81"x23,62"  
mix size

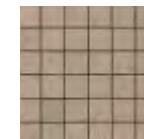

8,5 mm PTL272A  
10 mm PTL272\*\*  
30x30 . 11,81"x11,81"  
mosaico (36 pcs)

127 PORTLAND\_CONCRETE EFFECT

\*\* Disponibile fino ad esaurimento scorte | Available while stocks last |  
Disponibile jusqu'à épuisement des stocks | Verfügbar solange der  
Vorrat reicht



# pezzi speciali

Special trims | Pièces spéciales | Formteile

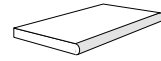

**2 cm**  
40x80x2 . 15,75"x31,50"x0,78"  
gradone toro lineare  
PTL321 *Jordan*  
PTL303 *Hood*  
PTL340 *Lassen*

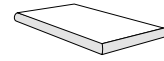

**2 cm**  
40x80x2 . 15,75"x31,50"x0,78"  
gradone toro angolare dx  
PTL322 *Jordan*  
PTL304 *Hood*  
PTL341 *Lassen*

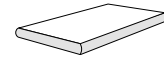

**2 cm**  
40x80x2 . 15,75"x31,50"x0,78"  
gradone toro angolare sx  
PTL323 *Jordan*  
PTL305 *Hood*  
PTL342 *Lassen*

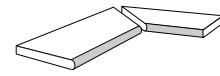

**2 cm**  
40x80x2 . 15,75"x31,50"x0,78"  
comp. gradone toro ang. interno  
PTL324 *Jordan*  
PTL302 *Hood*  
PTL343 *Lassen*

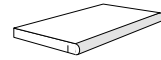

**2 cm**  
40x80x2 . 15,75"x31,50"x0,78"  
gradone toro lineare nodrip  
PTL325 *Jordan*  
PTL306 *Hood*  
PTL344 *Lassen*

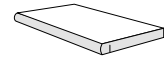

**2 cm**  
40x80x2 . 15,75"x31,50"x0,78"  
gradone toro angolare dx nodrip  
PTL326 *Jordan*  
PTL307 *Hood*  
PTL345 *Lassen*

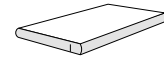

**2 cm**  
40x80x2 . 15,75"x31,50"x0,78"  
gradone toro angolare sx nodrip  
PTL327 *Jordan*  
PTL308 *Hood*  
PTL346 *Lassen*

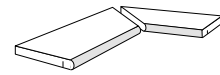

**2 cm**  
40x80x2 . 15,75"x31,50"x0,78"  
comp. gradone toro ang. interno nodrip  
PTL328 *Jordan*  
PTL309 *Hood*  
PTL347 *Lassen*

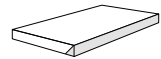

**2 cm**  
40x80x2 . 15,75"x31,50"x0,78"  
gradone cover lineare  
PTL332 *Jordan*  
PTL313 *Hood*  
PTL351 *Lassen*

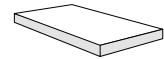

**2 cm**  
40x80x2 . 15,75"x31,50"x0,78"  
gradone cover angolare dx  
PTL333 *Jordan*  
PTL314 *Hood*  
PTL352 *Lassen*

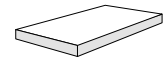

**2 cm**  
40x80x2 . 15,75"x31,50"x0,78"  
gradone cover angolare sx  
PTL334 *Jordan*  
PTL315 *Hood*  
PTL353 *Lassen*

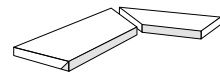

**2 cm**  
40x80x2 . 15,75"x31,50"x0,78"  
comp. gradone cover ang. interno  
PTL335 *Jordan*  
PTL316 *Hood*  
PTL354 *Lassen*

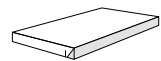

**2 cm**  
40x80x2 . 15,75"x31,50"x0,78"  
gradone cover lineare nodrip  
PTL336 *Jordan*  
PTL317 *Hood*  
PTL355 *Lassen*

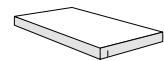

**2 cm**  
40x80x2 . 15,75"x31,50"x0,78"  
gradone cover angolare dx nodrip  
PTL337 *Jordan*  
PTL318 *Hood*  
PTL356 *Lassen*

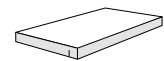

**2 cm**  
40x80x2 . 15,75"x31,50"x0,78"  
gradone cover angolare sx nodrip  
PTL338 *Jordan*  
PTL319 *Hood*  
PTL357 *Lassen*

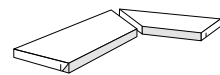

**2 cm**  
40x80x2 . 15,75"x31,50"x0,78"  
comp. gradone cover ang. interno nodrip  
PTL339 *Jordan*  
PTL320 *Hood*  
PTL358 *Lassen*

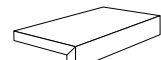

**2 cm**  
40x80x5 . 15,75"x31,50"x1,97  
elemento L lineare  
PTL329 *Jordan*  
PTL310 *Hood*  
PTL348 *Lassen*

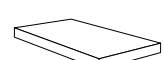

**2 cm**  
40x80x5 . 15,75"x31,50"x1,97  
elemento L angolare dx  
PTL330 *Jordan*  
PTL311 *Hood*  
PTL349 *Lassen*



**2 cm**  
40x80x5 . 15,75"x31,50"x1,97  
elemento L angolare sx  
PTL331 *Jordan*  
PTL312 *Hood*  
PTL350 *Lassen*

## 2.0UT







# action

Lastre di ceramica in gres porcellanato - Gruppo Bla UGL  
Porcelain stoneware slabs - Gruppe Bla UGL  
Dalles en céramique en grès cérame - Group Bla UGL  
Keramikplatten aus Feinsteinzeug - Gruppe Bla UGL

### THICKNESS



**6,5 mm**  
SELF LEVELING

### SURFACES

**Natural**  
Rettificato | Rectified |  
Rectifié | Rektifiziert

### TECH INFO

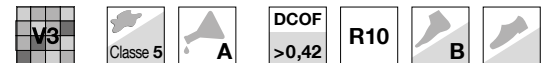

BS EN 16165\_C >  
Dry & Wet rubber 4S: ≥ 36  
AS 4586 > P3  
UNE-ENV 12633 > Class 2

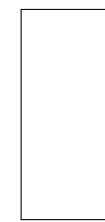

**120x278\***  
47,24"x109,45"

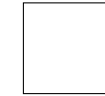

**120x120**  
47,24"x47,24"



**60x120**  
23,62"x47,24"

\* Lastre realizzate attraverso impasti colorati con colori standard | Slabs produced using coloured body mix available in standard shades

### COLORS



LIGHT



DARK





132 ACTION\_CONCRETE EFFECT

133 ACTION\_CONCRETE EFFECT





134 ACTION CONCRETE EFFECT

LIGHT

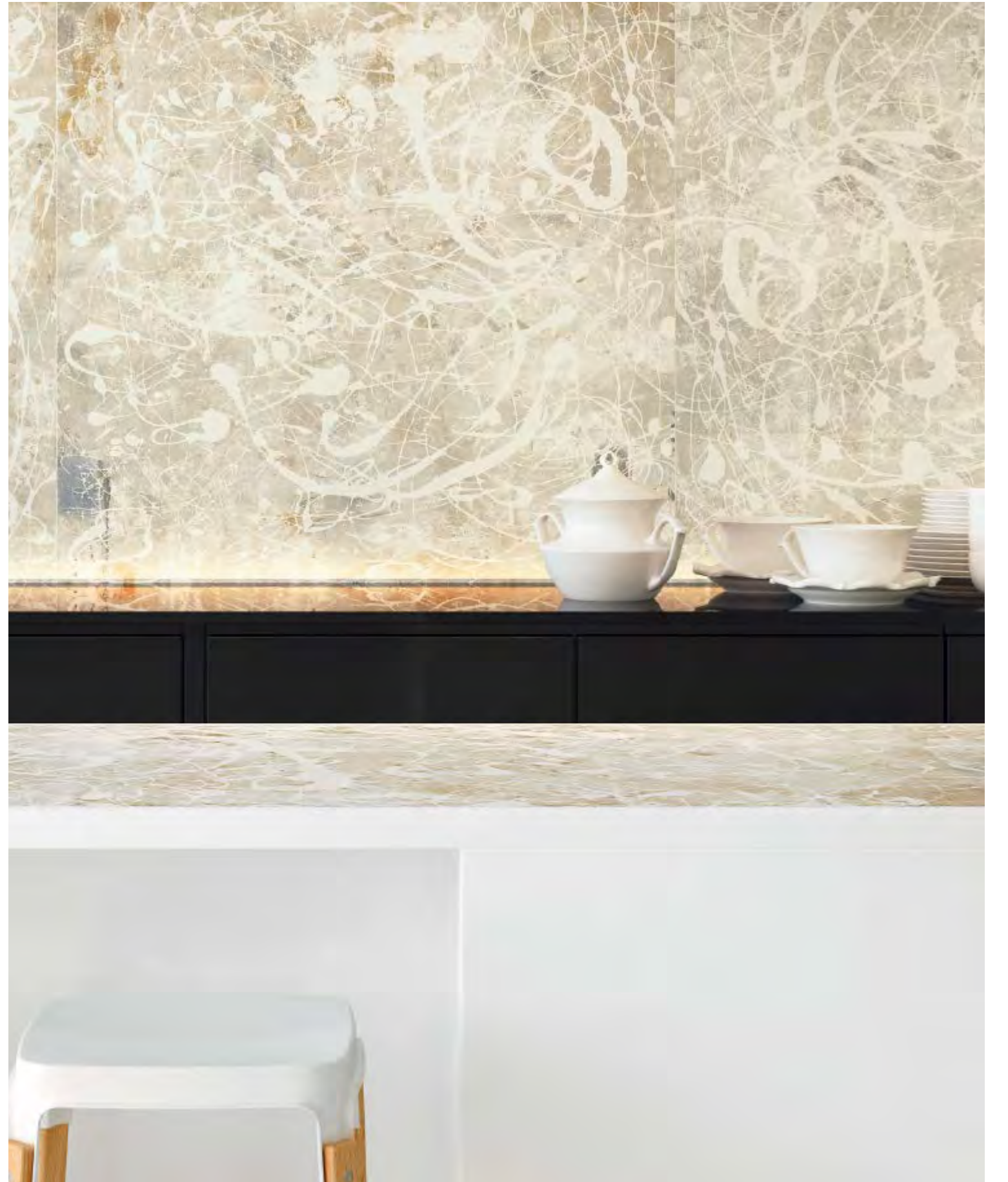

135 ACTION CONCRETE EFFECT

PAINT LIGHT WHITE



# action

REGISTERED DESIGN

## SIZES & SURFACES



**120x278\***  
47,24"x109,45"



**120x120**  
47,24"x47,24"



**60x120**  
23,62"x47,24"

**Natural**  
Rettificato | Rectified |  
Rectifié | Rektifiziert

**6,5 mm**

**120x278** . 47,24"x109,45"  
**ACT066**

**120x120** . 47,24"x47,24"  
**ACT014**

**60x120** . 23,62"x47,24"  
**ACT063**



**PAINT LIGHT WHITE**

**6,5 mm**  
**120x120** . 47,24"x47,24"  
deco  
**ACT018**

**Suggested grout**  
137 . Caribbean



**LIGHT**

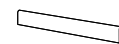

**6,5 mm**  
**8x120** . 3,15"x47,24"  
battiscopa  
**ACT009**



**6,5 mm**  
**33x120x5** . 12,99"x47,24"x1,97"  
gradino lineare LL  
**ACT010**

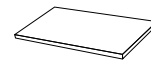

**6,5 mm**  
**33x120x5** . 12,99"x47,24"x1,97"  
gradino angolare LL  
**ACT016**

## LAYING EXAMPLE





# action

REGISTERED DESIGN

SIZES & SURFACES



**120x278\***  
47,24"x109,45"



**120x120**  
47,24"x47,24"



**60x120**  
23,62"x47,24"

**Natural**  
Rettificato | Rectified |  
Rectifié | Rektifiziert

**6,5 mm**

**120x278** . 47,24"x109,45"  
**ACT067**

**120x120** . 47,24"x47,24"  
**ACT004**

**60x120** . 23,62"x47,24"  
**ACT062**



**PAINT DARK WHITE**

**6,5 mm**  
**120x120** . 47,24"x47,24"  
deco  
**ACT008**

**Suggested grout**  
116 . Musk Grey



LAYING EXAMPLE



**DARK**

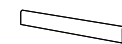

**6,5 mm**  
**8x120** . 3,15"x47,24"  
battiscopa  
**ACT019**



**6,5 mm**  
**33x120x5** . 12,99"x47,24"x1,97"  
gradino lineare LL  
**ACT020**



**6,5 mm**  
**33x120x5** . 12,99"x47,24"x1,97"  
gradino angolare LL  
**ACT006**





Effetto Resina  
Effet Résine  
Harz-Effekt

**resin  
effect**

142 Res Art



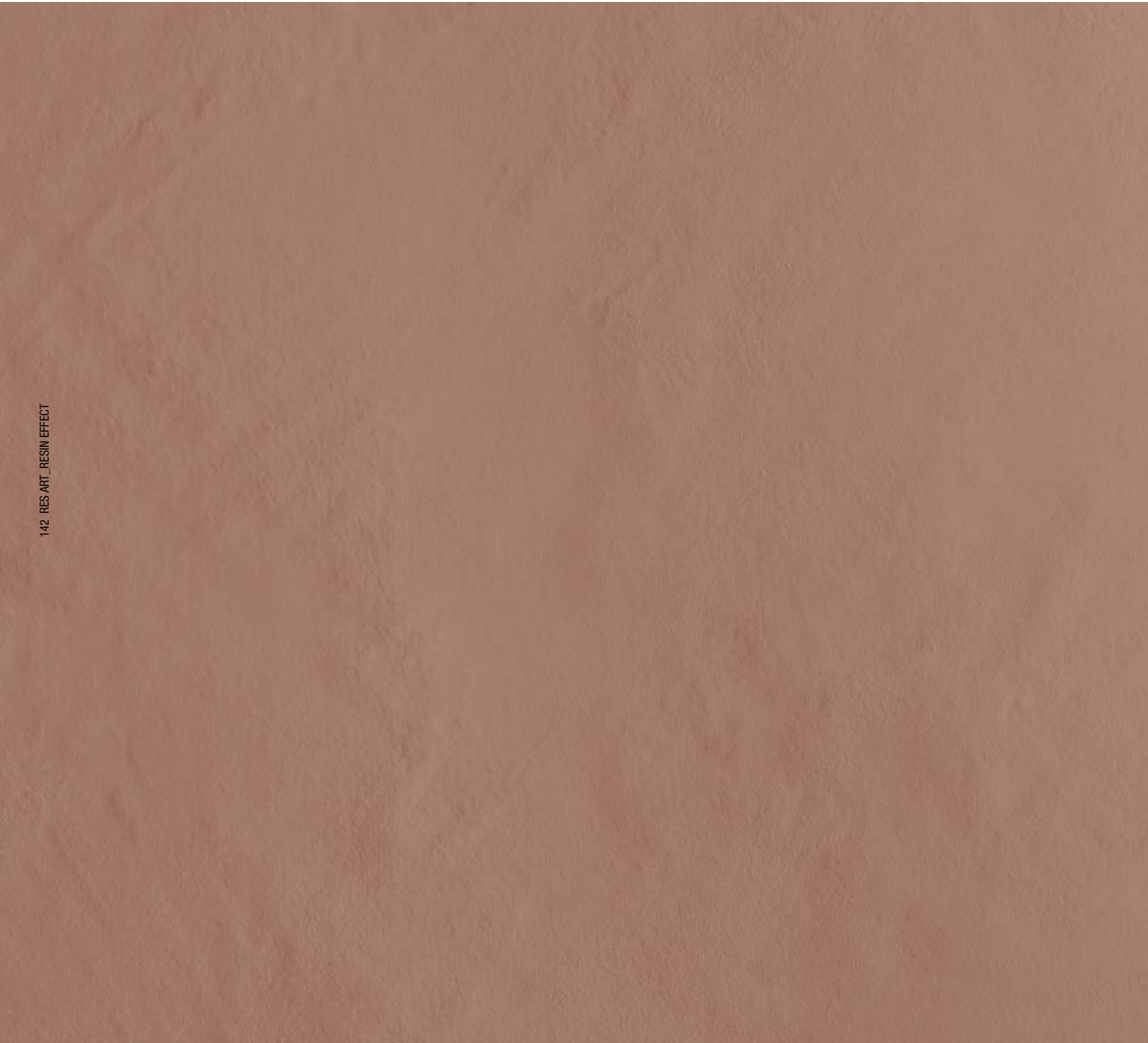

# res art

Lastre di ceramica in gres porcellanato - Gruppo Bla UGL  
 Porcelain stoneware slabs - Gruppe Bla UGL  
 Dalles en céramique en grès cérame - Group Bla UGL  
 Keramikplatten aus Feinsteinzeug - Gruppe Bla UGL

## THICKNESS



6,5 mm  
 SELF LEVELING

## SURFACES

**Natural**  
 Rettificato | Rectified |  
 Rectifié | Rektifiziert

## TECH INFO



BS EN 16165\_C >  
 Dry & Wet rubber 4S:  
 on request ≥ 36  
 AS 4586 > P3: on request  
 UNE-ENV 12633 >  
 Class 2: on request



120x278\*  
 47,24"x109,45"



120x120  
 47,24"x47,24"



60x120  
 23,62"x47,24"

\* Lastre realizzate attraverso impasti colorati con colori standard | Slabs produced using coloured body mix available in standard shades

## COLORS



TALC

ASH

POWDER

MUD

LAVA

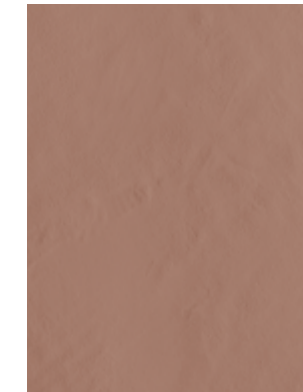

POTTERY



OLIVE



AVIO



CAMEO









146 RES ART\_RESIN EFFECT

CAMEO



147 RES ART\_RESIN EFFECT

TALC / LAVA









151 RES ART \_ RESIN EFFECT

OLIVE



151 RES ART \_ RESIN EFFECT

POWDER



# res art

152 RES ART\_RESIN EFFECT



## SIZES & SURFACES



**120x278\***  
47,24"x109,45"



**120x120**  
47,24"x47,24"



**60x120**  
23,62"x47,24"

**Natural**  
Rettificato | Rectified |  
Rectifié | Rektifiziert

**6,5 mm**

**120x278** . 47,24"x109,45"  
**RES217**

**120x120** . 47,24"x47,24"  
**RES178**

**60x120** . 23,62"x47,24"  
**RES192**



**6,5 mm**  
**5x30** . 1,97"x11,81"  
listello  
**RES259**

**Suggested grout**  
103 . Moon White

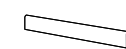

**6,5 mm**  
**8x120** . 3,15"x47,24"  
battiscopa  
**RES199**



**6,5 mm**  
**33x120x5** . 12,99"x47,24"x1,97"  
gradino lineare LL  
**RES078**



**6,5 mm**  
**33x120x5** . 12,99"x47,24"x1,97"  
gradino angolare LL  
**RES085**



## SIZES & SURFACES



**120x278\***  
47,24"x109,45"



**120x120**  
47,24"x47,24"



**60x120**  
23,62"x47,24"

**Natural**  
Rettificato | Rectified |  
Rectifié | Rektifiziert

**6,5 mm**

**120x278** . 47,24"x109,45"  
**RES218**

**120x120** . 47,24"x47,24"  
**RES179**

**60x120** . 23,62"x47,24"  
**RES193**



**6,5 mm**  
**5x30** . 1,97"x11,81"  
listello  
**RES260**

**Suggested grout**  
112 . Medium Grey

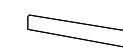

**6,5 mm**  
**8x120** . 3,15"x47,24"  
battiscopa  
**RES200**



**6,5 mm**  
**33x120x5** . 12,99"x47,24"x1,97"  
gradino lineare LL  
**RES079**

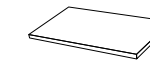

**6,5 mm**  
**33x120x5** . 12,99"x47,24"x1,97"  
gradino angolare LL  
**RES086**

153 RES ART\_RESIN EFFECT



# res art

154 RES ART\_RESIN EFFECT

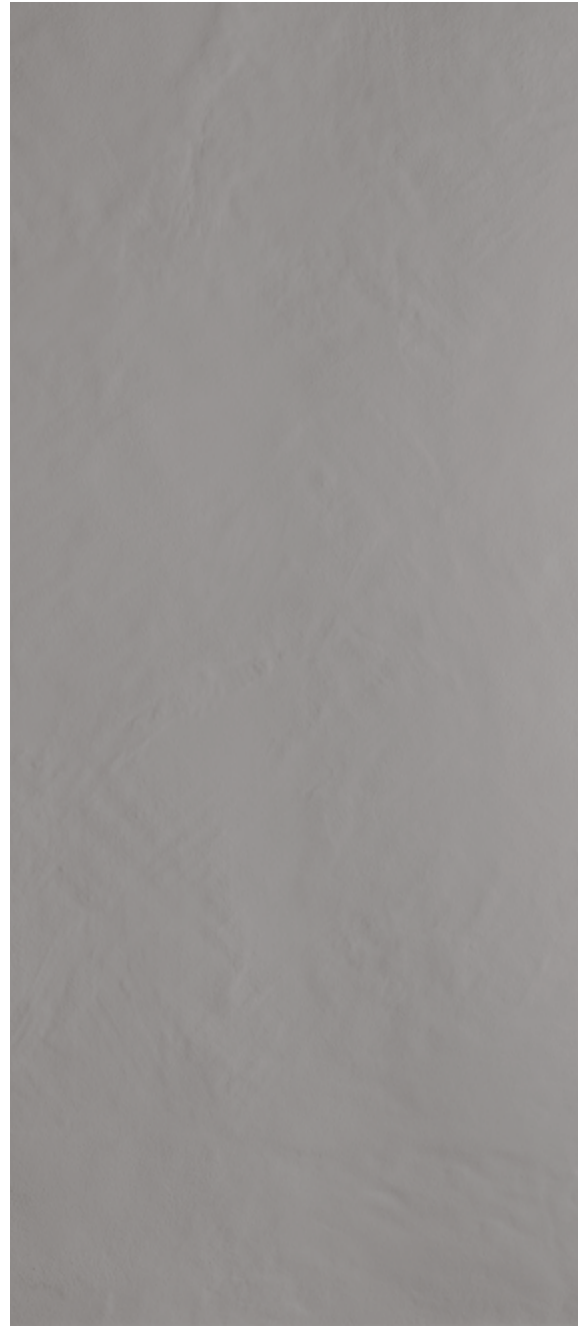

## SIZES & SURFACES



**120x278\***  
47,24"x109,45"



**120x120**  
47,24"x47,24"



**60x120**  
23,62"x47,24"

**Natural**  
Rettificato | Rectified |  
Rectifié | Rektifiziert

**6,5 mm**

**120x278** . 47,24"x109,45"  
**RES219**

**120x120** . 47,24"x47,24"  
**RES180**

**60x120** . 23,62"x47,24"  
**RES194**



**6,5 mm**  
**5x30** . 1,97"x11,81"  
listello  
**RES261**

**Suggested grout**  
119 . London Grey

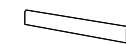

**6,5 mm**  
**8x120** . 3,15"x47,24"  
battiscopa  
**RES201**



**6,5 mm**  
**33x120x5** . 12,99"x47,24"x1,97"  
gradino lineare LL  
**RES080**



**6,5 mm**  
**33x120x5** . 12,99"x47,24"x1,97"  
gradino angolare LL  
**RES087**



## SIZES & SURFACES



**120x278\***  
47,24"x109,45"



**120x120**  
47,24"x47,24"



**60x120**  
23,62"x47,24"

**Natural**  
Rettificato | Rectified |  
Rectifié | Rektifiziert

**6,5 mm**

**120x278** . 47,24"x109,45"  
**RES220**

**120x120** . 47,24"x47,24"  
**RES181**

**60x120** . 23,62"x47,24"  
**RES195**



**6,5 mm**  
**5x30** . 1,97"x11,81"  
listello  
**RES262**

**Suggested grout**  
113 . Cement Grey

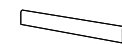

**6,5 mm**  
**8x120** . 3,15"x47,24"  
battiscopa  
**RES202**

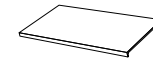

**6,5 mm**  
**33x120x5** . 12,99"x47,24"x1,97"  
gradino lineare LL  
**RES081**

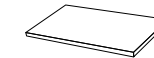

**6,5 mm**  
**33x120x5** . 12,99"x47,24"x1,97"  
gradino angolare LL  
**RES088**

155 RES ART\_RESIN EFFECT



# res art

156 RES ART\_RESIN EFFECT

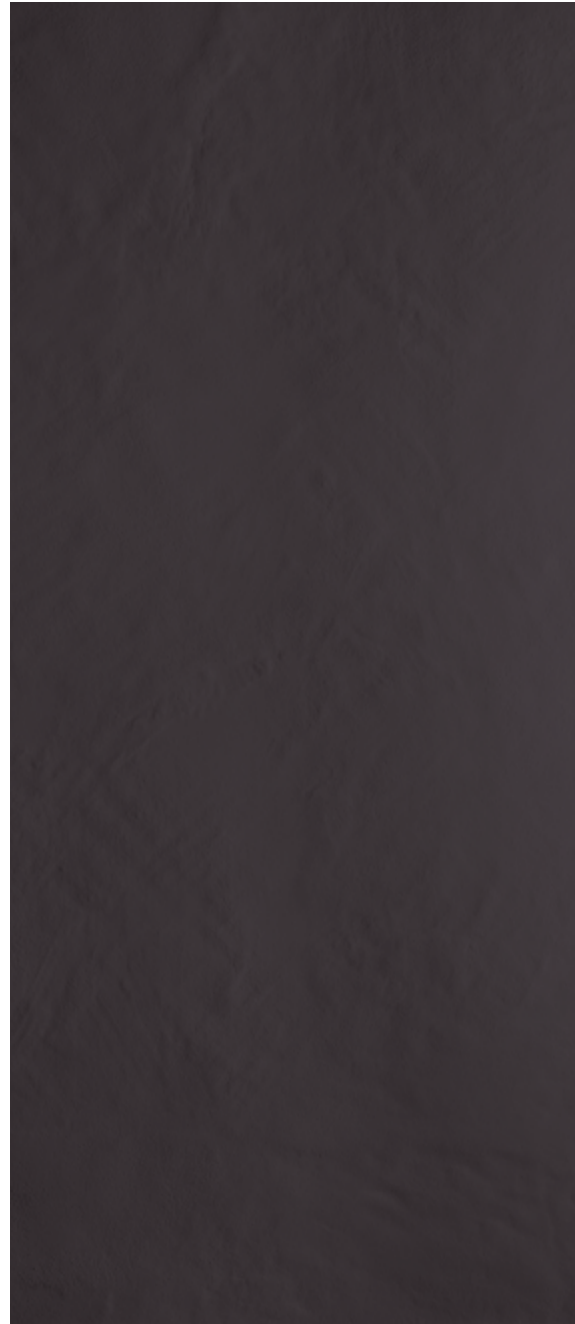

## SIZES & SURFACES



**120x278\***  
47,24"x109,45"



**120x120**  
47,24"x47,24"



**60x120**  
23,62"x47,24"

**Natural**  
Rettificato | Rectified |  
Rectifié | Rektifiziert

**6,5 mm**

**120x278** . 47,24"x109,45"  
**RES221**

**120x120** . 47,24"x47,24"  
**RES182**

**60x120** . 23,62"x47,24"  
**RES196**



**6,5 mm**  
5x30 . 1,97"x11,81"  
listello  
**RES263**

**Suggested grout**  
120 . Black

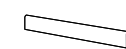

**6,5 mm**  
8x120 . 3,15"x47,24"  
battiscopa  
**RES203**



**6,5 mm**  
33x120x5 . 12,99"x47,24"x1,97"  
gradino lineare LL  
**RES082**



**6,5 mm**  
33x120x5 . 12,99"x47,24"x1,97"  
gradino angolare LL  
**RES089**



## SIZES & SURFACES



**120x278\***  
47,24"x109,45"



**120x120**  
47,24"x47,24"



**60x120**  
23,62"x47,24"

**Natural**  
Rettificato | Rectified |  
Rectifié | Rektifiziert

**6,5 mm**

**120x278** . 47,24"x109,45"  
**RES222**

**120x120** . 47,24"x47,24"  
**RES183**

**60x120** . 23,62"x47,24"  
**RES197**



**6,5 mm**  
5x30 . 1,97"x11,81"  
listello  
**RES264**

**Suggested grout**  
134 . Silk

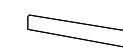

**6,5 mm**  
8x120 . 3,15"x47,24"  
battiscopa  
**RES204**

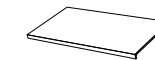

**6,5 mm**  
33x120x5 . 12,99"x47,24"x1,97"  
gradino lineare LL  
**RES206**

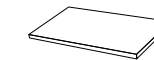

**6,5 mm**  
33x120x5 . 12,99"x47,24"x1,97"  
gradino angolare LL  
**RES207**

157 RES ART\_RESIN EFFECT



# res art

158 RES ART\_RESIN EFFECT



## SIZES & SURFACES



**120x278\***  
47,24"x109,45"



**120x120**  
47,24"x47,24"



**60x120**  
23,62"x47,24"

**Natural**  
Rettificato | Rectified |  
Rectifié | Rektifiziert

**6,5 mm**

**120x278** . 47,24"x109,45"  
**RES238**

**120x120** . 47,24"x47,24"  
**RES232**

**60x120** . 23,62"x47,24"  
**RES234**

**6,5 mm**  
5x30 . 1,97"x11,81"  
listello  
**RES266**

**Suggested grout**  
115 . River Grey



**6,5 mm**  
8x120 . 3,15"x47,24"  
battiscopa  
**RES248**

**6,5 mm**  
33x120x5 . 12,99"x47,24"x1,97"  
gradino lineare LL  
**RES250**

**6,5 mm**  
33x120x5 . 12,99"x47,24"x1,97"  
gradino angolare LL  
**RES252**

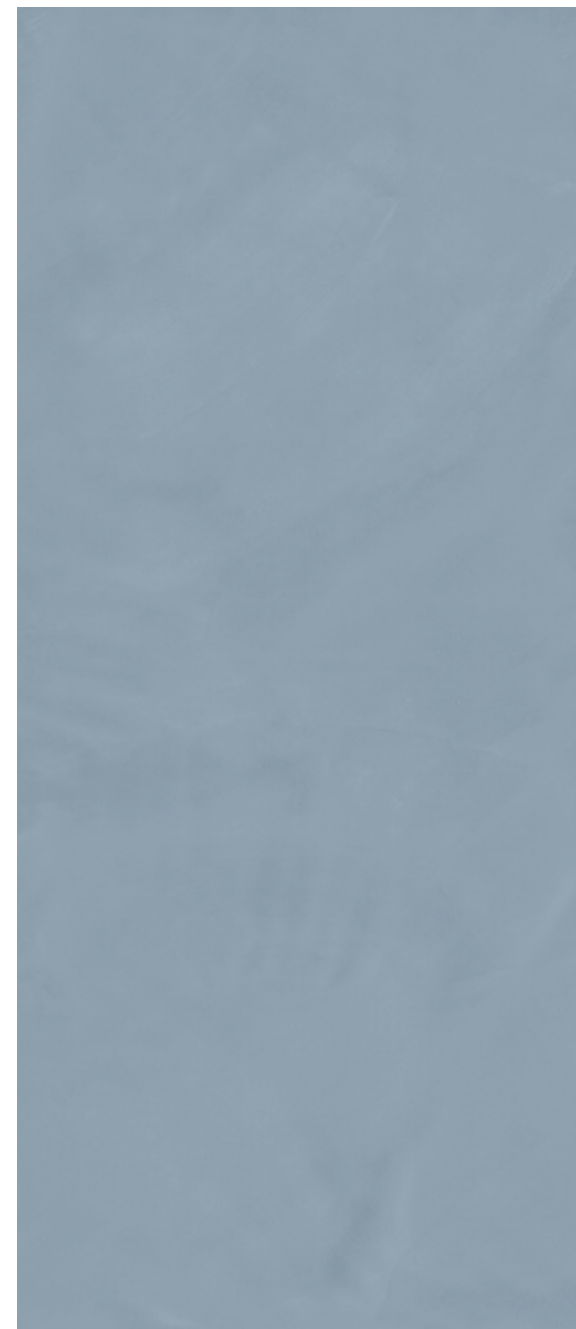

## SIZES & SURFACES



**120x278\***  
47,24"x109,45"



**120x120**  
47,24"x47,24"



**60x120**  
23,62"x47,24"

**Natural**  
Rettificato | Rectified |  
Rectifié | Rektifiziert

**6,5 mm**

**120x278** . 47,24"x109,45"  
**RES239**

**120x120** . 47,24"x47,24"  
**RES233**

**60x120** . 23,62"x47,24"  
**RES235**

**6,5 mm**  
5x30 . 1,97"x11,81"  
listello  
**RES267**

**Suggested grout**  
170 . Crocus Blue



**6,5 mm**  
8x120 . 3,15"x47,24"  
battiscopa  
**RES249**

**6,5 mm**  
33x120x5 . 12,99"x47,24"x1,97"  
gradino lineare LL  
**RES251**

**6,5 mm**  
33x120x5 . 12,99"x47,24"x1,97"  
gradino angolare LL  
**RES253**

159 RES ART\_RESIN EFFECT



# res art

160 RES ART\_RESIN EFFECT



## SIZES & SURFACES



**120x278\***  
47,24"x109,45"



**120x120**  
47,24"x47,24"



**60x120**  
23,62"x47,24"

**Natural**  
Rettificato | Rectified |  
Rectifié | Rektifiziert

**6,5 mm**

**120x278** . 47,24"x109,45"  
**RES295**

**120x120** . 47,24"x47,24"  
**RES292**

**60x120** . 23,62"x47,24"  
**RES293**



**6,5 mm**  
5x30 . 1,97"x11,81"  
listello  
**RES300**

**Suggested grout**  
132 . Beige 2000



**CAMEO**

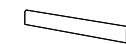

**6,5 mm**  
8x120 . 3,15"x47,24"  
battiscopa  
**RES296**

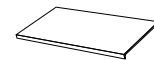

**6,5 mm**  
33x120x5 . 12,99"x47,24"x1,97"  
gradino lineare LL  
**RES297**



**6,5 mm**  
33x120x5 . 12,99"x47,24"x1,97"  
gradino angolare LL  
**RES298**

## MOSAICO BALL



**TALC**  
6,5 mm  
28,8x31,2 . 11,34"x12,28"  
**RES171**



**ASH**  
6,5 mm  
28,8x31,2 . 11,34"x12,28"  
**RES172**



**POWDER**  
6,5 mm  
28,8x31,2 . 11,34"x12,28"  
**RES173**

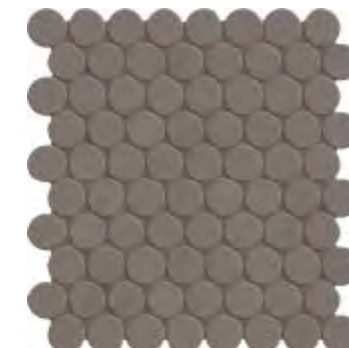

**MUD**  
6,5 mm  
28,8x31,2 . 11,34"x12,28"  
**RES174**



**LAVA**  
6,5 mm  
28,8x31,2 . 11,34"x12,28"  
**RES175**



**POTTERY**  
6,5 mm  
28,8x31,2 . 11,34"x12,28"  
**RES176**

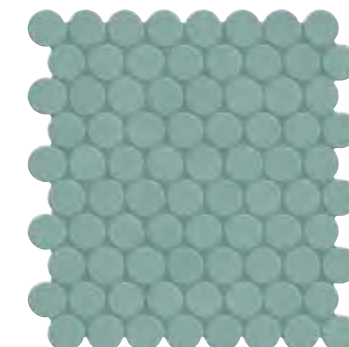

**OLIVE**  
6,5 mm  
28,8x31,2 . 11,34"x12,28"  
**RES254**

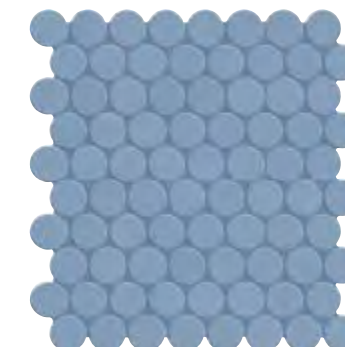

**AVIO**  
6,5 mm  
28,8x31,2 . 11,34"x12,28"  
**RES255**



**CAMEO**  
6,5 mm  
28,8x31,2 . 11,34"x12,28"  
**RES299**

161 RES ART\_RESIN EFFECT



# res art

## LISTELLO

Il listello Res Art si abbinata armoniosamente con le superfici Keynote attraverso l'accostamento di colori differenti delle 2 collezioni secondo schemi di posa variabili. | The Res Art strips pair perfectly with Keynote, with the different colours from the two collections put together in a variety of arrangements to stunning effect. | Le listel Rex Art se combine harmonieusement avec les surfaces Keynote grâce à la combinaison de différentes couleurs des 2 collections selon des schémas de pose variables. | Die Leiste Res Art passt durch die Kombination mit verschiedenen Farben der 2 Kollektionen entsprechend der variablen Verlegemuster auf harmonische Weise zu den Oberflächen Keynote.

Abbinamenti consigliati | Suggested mix and match | Assortiments conseillés | Empfohlene Kombinationen

### KEYNOTE COLORS

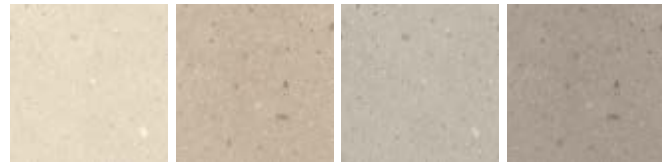

PEARL

AMBER

ARCTIC

COOL GREY

Alcuni suggerimenti di posa | Laying suggestions | Quelques conseils de pose | Einige Empfehlungen zur Verlegung

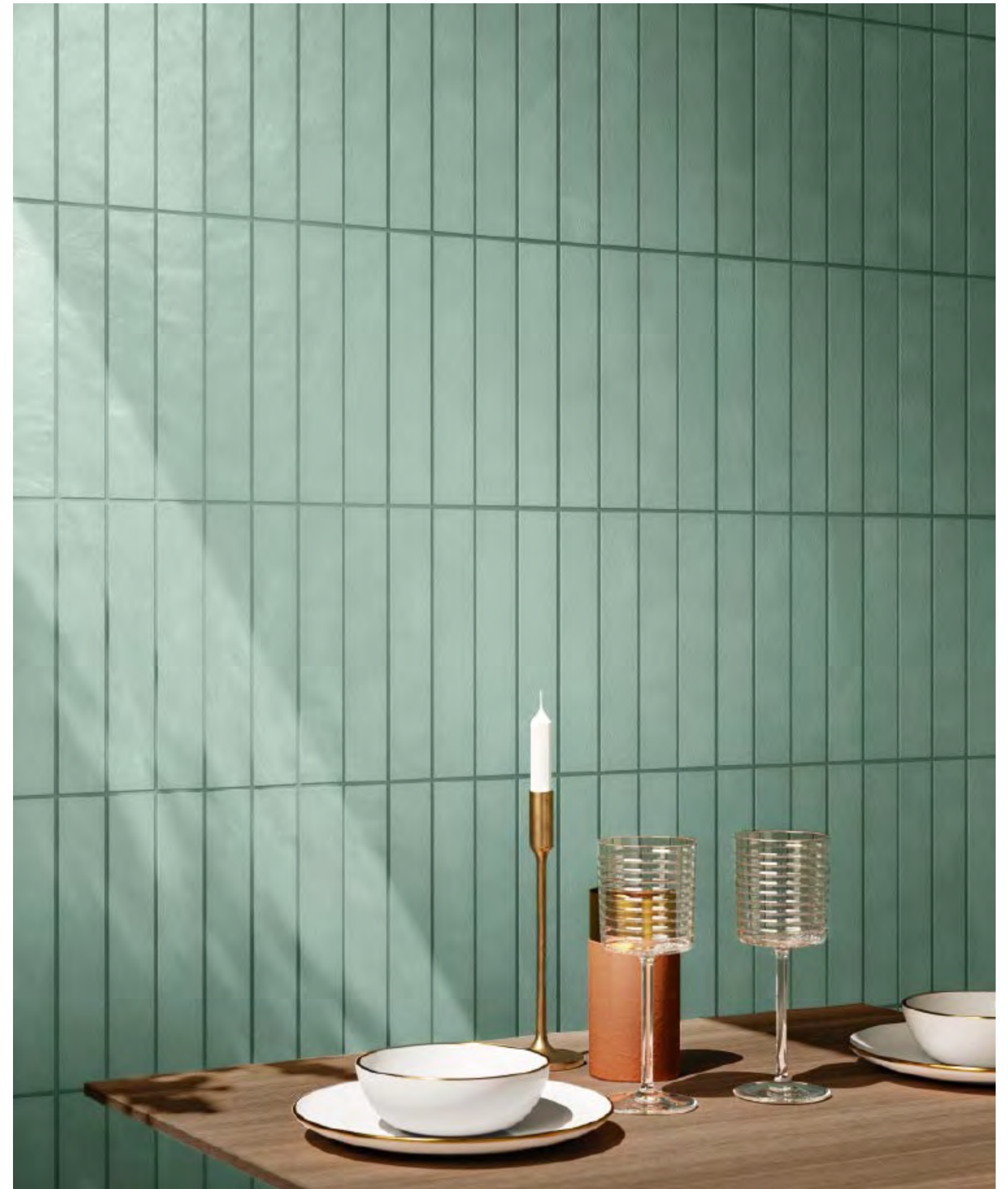
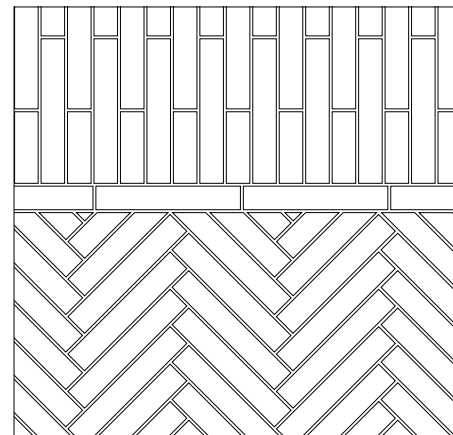
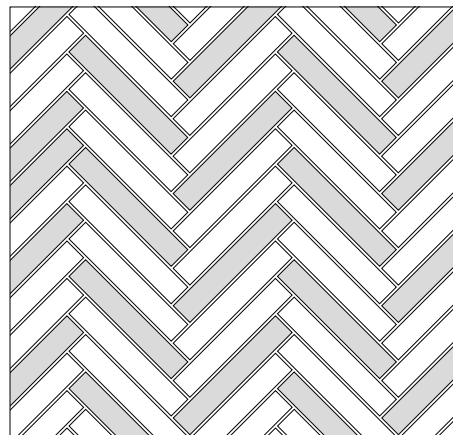
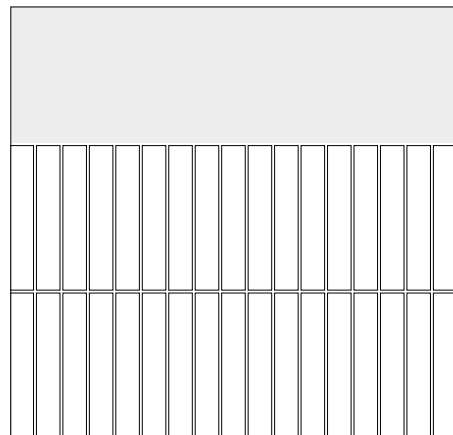
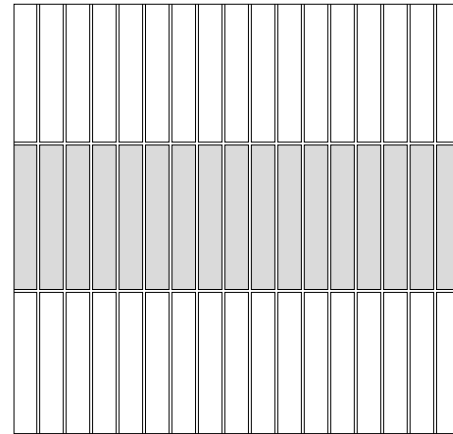
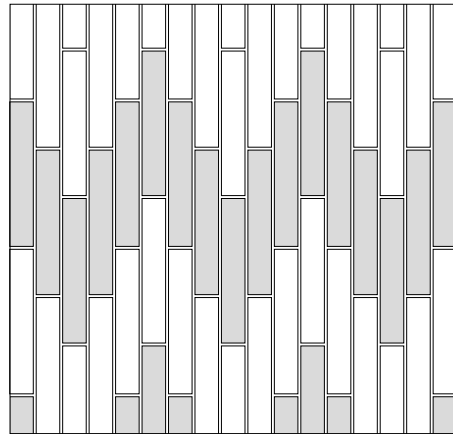
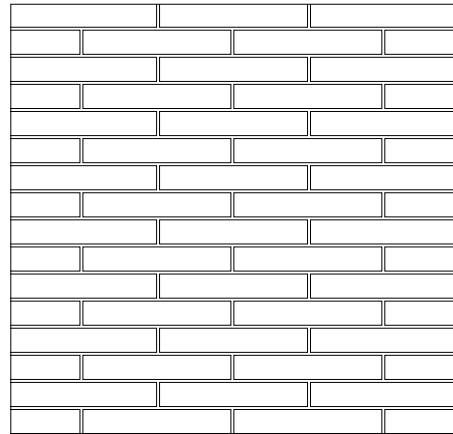





Effetto Marmo  
Effet Marbre  
Marmor-Effekt

# marble effect

166 Infinito 2.0





# infinito 2.0

Lastre di ceramica in gres porcellanato - Gruppo Bla UGL  
 Porcelain stoneware slabs - Gruppe Bla UGL  
 Dalles en céramique en grès céram - Group Bla UGL  
 Keramikplatten aus Feinsteinzeug - Groupe Bla UGL

## THICKNESS



6,5 mm  
SELF LEVELING

## SURFACES

Glossy / Honed / Natural  
 Rettificato | Rectified |  
 Rectifié | Rektifiziert

## TECH INFO

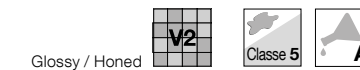

Glossy / Honed

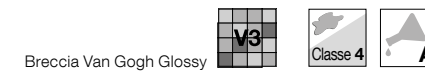

Breccia Van Gogh Glossy



Natural

BS EN 16165\_C >  
 Dry & Wet rubber 4S:  
 on request ≥ 36  
 AS 4586 > P3: on request  
 UNE-ENV 12633 >  
 Class 2: on request

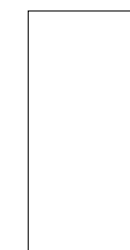

160x320\*  
62,99"x125,98"



120x278\*\*  
47,24"x109,45"



60x120  
23,62"x47,24"

\* Lastre realizzate attraverso impasti tecnici colorati con colori dedicati | Slabs produced using coloured body mix with technical features available in dedicated shades  
 \*\* Lastre realizzate attraverso impasti colorati con colori standard | Slabs produced using coloured body mix available in standard shades

## COLORS

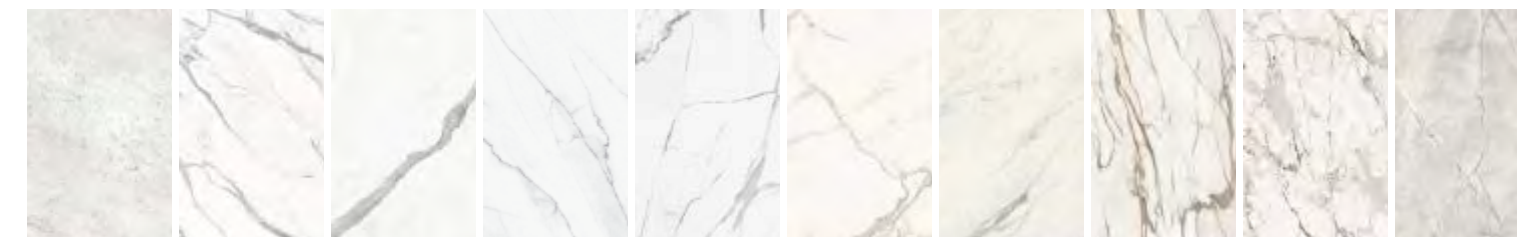

CARRARA C STATUARIO EXTRA STATUARIO LINCOLN CALACATTA WHITE CALACATTA LIGHT ELEGANT WHITE CALACATTA GOLD CAPRAIA SUPER WHITE

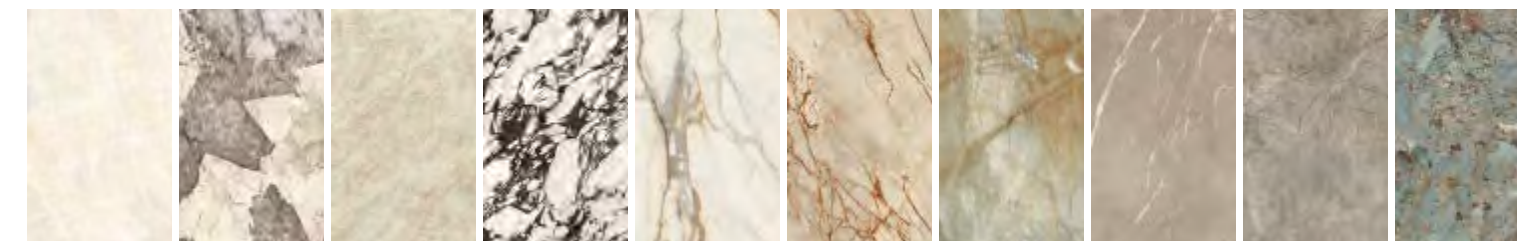

ONICE WHITE PATAGONIA TAJ MAHAL CALACATTA VIOLA CALACATTA MACCHIA VECCHIA GOLD RIVER BRECCIA VAN GOGH ROYAL CREAMY FIOR DI BOSCO AMAZZONITE

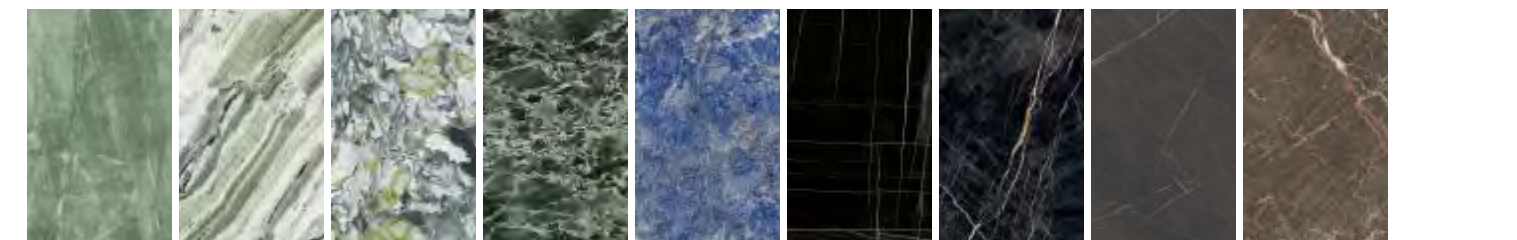

EMERALD GREEN RIVER JADE WHITE BEAUTY GREEN DENIS SODALITE BLUE SAHARA NOIR PORT LAURENT PIETRA GREY OMBRA DI CARAVAGGIO







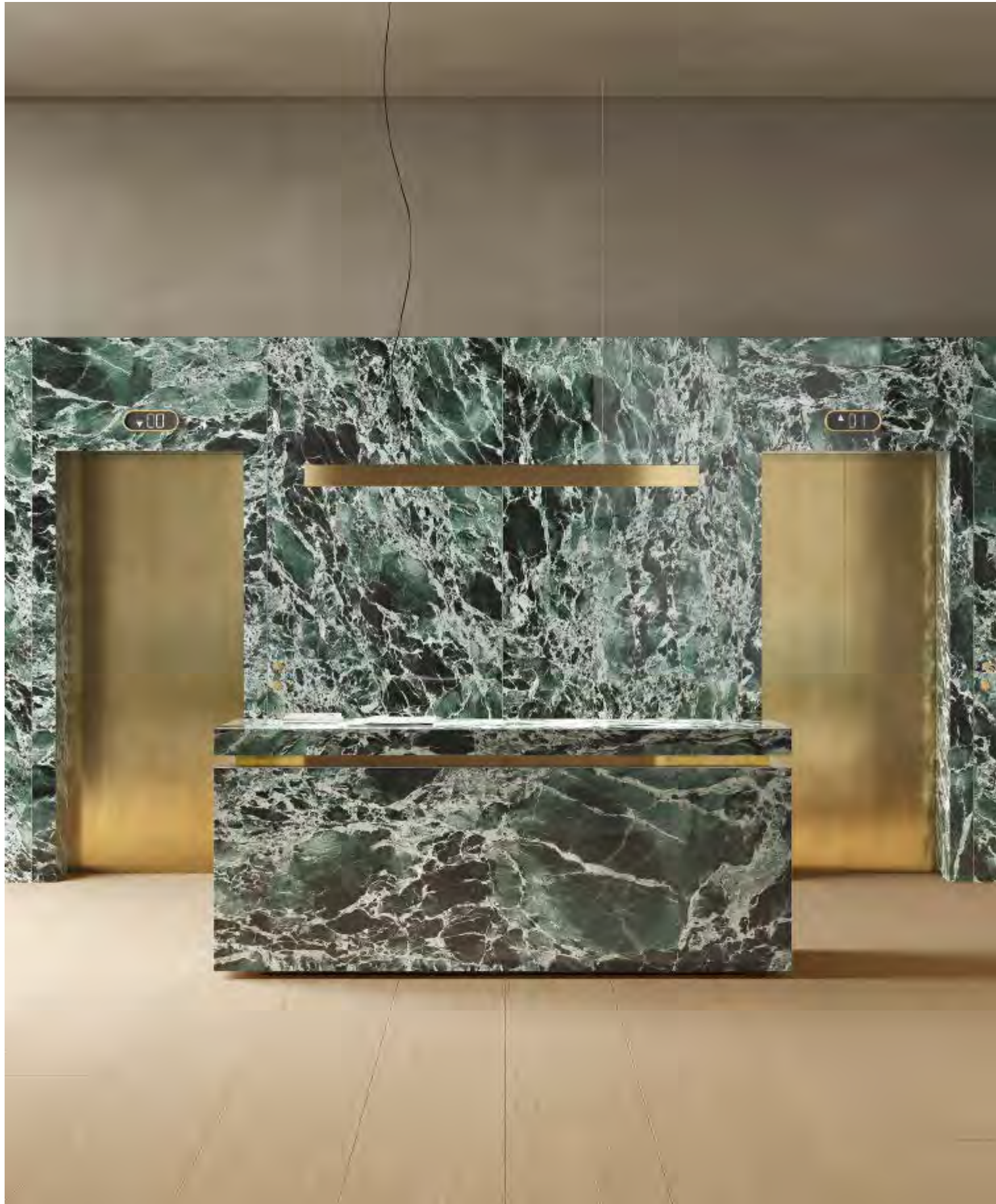

GREEN DENIS



CALACATTA VIOLA



172 INFINITO 2.0\_MARBLE EFFECT



173 INFINITO 2.0\_MARBLE EFFECT





174 INFINITO 2.0\_MARBLE EFFECT

RIVER JADE



175 INFINITO 2.0\_MARBLE EFFECT

PIETRA GREY















182 INFINITO 2.0\_MARBLE EFFECT



183 INFINITO 2.0\_MARBLE EFFECT







186 THE BRAND



187 THE BRAND



STATUARIO EXTRA









CALACATTA MACCHIA VECCHIA



STATUARIO





















200 INFINITO 2.0\_MARBLE EFFECT

201 INFINITO 2.0\_MARBLE EFFECT





# infinito 2.0

REGISTERED DESIGN

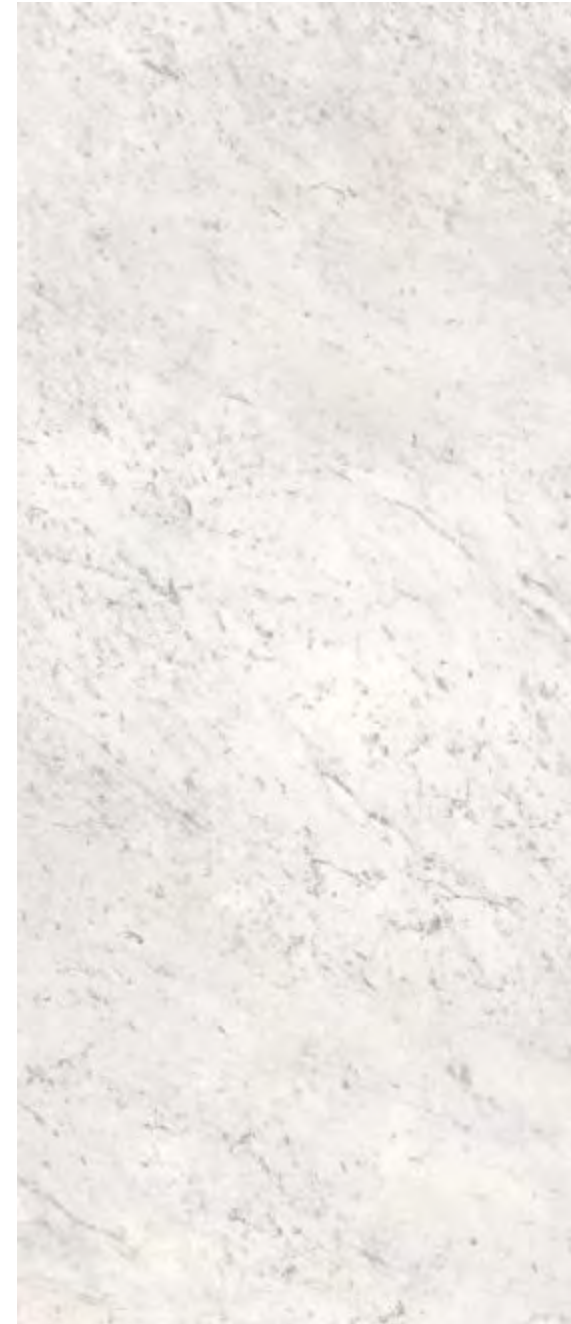

SIZES & SURFACES



**160x320\***  
62,99"x125,98"



**120x278\*\***  
47,24"x109,45"



**60x120**  
23,62"x47,24"

**6,5 mm**

**Glossy**  
Rettificato | Rectified |  
Rectifié | Rektifiziert

- **160x320** . 62,99"x125,98"  
**INF1096**

**120x278** . 47,24"x109,45"  
**INF1138**

**60x120** . 23,62"x47,24"  
**INF1101**

**Honed**  
Rettificato | Rectified |  
Rectifié | Rektifiziert

- **160x320** . 62,99"x125,98"  
**INF1095**

**120x278** . 47,24"x109,45"  
**INF1137**

• Disponibile su richiesta | Available on request | Disponible sur demande |  
Auf Anfrage erhältlich

**CARRARA C**

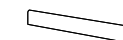

**6,5 mm**  
**8x120** . 3,15"x47,24"  
battiscopa  
**INF1103** glossy



**6,5 mm**  
**33x120x5** . 12,99"x47,24"x1,97"  
gradino lineare LL  
**INF1106** glossy

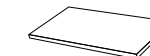

**6,5 mm**  
**33x120x5** . 12,99"x47,24"x1,97"  
gradino angolare LL  
**INF1107** glossy

**Wall suggested grout**  
103 . Moon White



**Floor suggested grout**  
110 . Manhattan 2000





# infinito 2.0

REGISTERED DESIGN

GRAPHICS 120x278



204 INFINITO 2.0\_MARBLE EFFECT

205 INFINITO 2.0\_MARBLE EFFECT

CARRARA C

Nel formato 120x278 il "Carrara C" è prodotto in 5 differenti facce per accentuare l'effetto naturale tipico del marmo. In fase di approntamento dell'ordine, la selezione delle facce è random, pertanto la venatura continuativa fra i diversi pezzi non è garantita. Rispettare la successione raffigurata per ricreare la sincronizzazione. La prima lastra raffigurata si aggancia alla quinta per garantire una soluzione infinita. L'effetto vena continua fra i diversi pezzi è soggetta alla tolleranza tipica del prodotto lapideo. | In the 120x278 size, "Carrara C" is available with five different faces, to accentuate the natural look so typical of marble. When preparing the order, the different versions are chosen randomly, which means continuous veining between the different pieces is not guaranteed. Follow the sequence shown to recreate the synchronised effect. To ensure an endless finish, the sequence must be repeated continually, with the first slab placed after the fifth. The continuous veining effect across the various tiles is subject to the typical tolerance of stone products. | Dans le format 120x278 le "Carrara C" est produit en 5 faces différentes pour accentuer l'effet naturel typique du marbre. Au moment de la préparation de la commande,

la sélection des faces est fortuite ; la continuité des veines entre les différentes pièces n'est donc pas garantie. Respecter la succession représentée pour recréer la synchronisation. La première dalle représentée s'accroche à la cinquième pour garantir une solution infinie. L'effet de la veine continue entre les différentes pièces est soumis à la tolérance typique du produit en pierre. | Beim Format 120x278 wird der "Carrara C" in 5 verschiedenen Oberflächen hergestellt, um den natürlichen Effekt hervorzuheben, der für den Marmor typisch ist. Bei der Vorbereitung des Auftrags erfolgt die Auswahl der Oberflächen nach Zufall, weshalb die durchgehende Aderung zwischen den verschiedenen Teilen nicht garantiert ist. Halten Sie die dargestellte Reihenfolge ein, um die Synchronisierung nachzubilden. Die erste dargestellte Platte schließt sich an die fünfte an, um eine unendliche Lösung zu garantieren. Der Effekt der durchgehenden Aderung zwischen den verschiedenen Teilen unterliegt der typischen Toleranz des Produktes aus Stein.



# infinito 2.0

REGISTERED DESIGN

GRAPHICS 160x320



206 INFINITO 2.0\_MARBLE EFFECT

207 INFINITO 2.0\_MARBLE EFFECT

CARRARA C

Nel formato 160x320 il "Carrara C." è prodotto in 4 differenti facce per accentuare l'effetto naturale tipico del marmo. In fase di approntamento dell'ordine, la selezione delle facce è random, pertanto la venatura continuativa fra i diversi pezzi non è garantita. Rispettare la successione raffigurata per ricreare la sincronizzazione. La prima lastra raffigurata si aggancia alla quarta per garantire una soluzione infinita. L'effetto vena continua fra i diversi pezzi è soggetta alla tolleranza tipica del prodotto lapideo. | In the 160x320 size, "Carrara C." is available with four different faces, to accentuate the natural look so typical of marble. When preparing the order, the different versions are chosen randomly, which means continuous veining between the different pieces is not guaranteed. Follow the sequence shown to recreate the synchronised effect. To ensure an endless finish, the sequence must be repeated continually, with the first slab placed after the fourth. The continuous veining effect across the various tiles is subject to the typical tolerance of stone products. | Dans le format 160x320 le "Carrara C." est produit en 4 faces différentes pour accentuer l'effet naturel typique du marbre. Au moment de la préparation de la commande, la sélection des faces est fortuite ; la continuité des

veines entre les différentes pièces n'est donc pas garantie. Respecter la succession représentée pour recréer la synchronisation. La première dalle représentée s'accroche à la quatrième pour garantir une solution infinie. L'effet de la veine continue entre les différentes pièces est soumis à la tolérance typique du produit en pierre. | Beim Format 160x320 wird der "Carrara C." in 4 verschiedenen Oberflächen hergestellt, um den natürlichen Effekt hervorzuheben, der für den Marmor typisch ist. Bei der Vorbereitung des Auftrags erfolgt die Auswahl der Oberflächen nach Zufall, weshalb die durchgehende Aderung zwischen den verschiedenen Teilen nicht garantiert ist. Halten Sie die dargestellte Reihenfolge ein, um die Synchronisierung nachzubilden. Die erste dargestellte Platte schließt sich an die vierte an, um eine unendliche Lösung zu garantieren. Der Effekt der durchgehenden Aderung zwischen den verschiedenen Teilen unterliegt der typischen Toleranz des Produktes aus Stein.



# infinito 2.0

REGISTERED DESIGN

## SIZES & SURFACES



**160x320\***  
62,99"x125,98"



**120x278\*\***  
47,24"x109,45"



**60x120**  
23,62"x47,24"

### 6,5 mm

**Glossy**  
Rettificato | Rectified |  
Rectifié | Rektifiziert

- **160x320** . 62,99"x125,98"  
**INF1042**

**120x278** . 47,24"x109,45"  
**INF1165**

**60x120** . 23,62"x47,24"  
**INF1058**

**Honed**  
Rettificato | Rectified |  
Rectifié | Rektifiziert

- **160x320** . 62,99"x125,98"  
**INF1041**

**120x278** . 47,24"x109,45"  
**INF1164**

**Natural**  
Rettificato | Rectified |  
Rectifié | Rektifiziert

**120x278** . 47,24"x109,45"  
**INF1909**

- Disponibile su richiesta | Available on request | Disponible sur demande | Auf Anfrage erhältlich



STATUARIO EXTRA

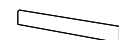

**6,5 mm**  
**8x120** . 3,15"x47,24"  
battiscopa  
**INF1060** glossy



**6,5 mm**  
**33x120x5** . 12,99"x47,24"x1,97"  
gradino lineare LL  
**INF1062** glossy



**6,5 mm**  
**33x120x5** . 12,99"x47,24"x1,97"  
gradino angolare LL  
**INF1064** glossy

**Wall suggested grout**  
103 . Moon White



**Floor suggested grout**  
110 . Manhattan 2000

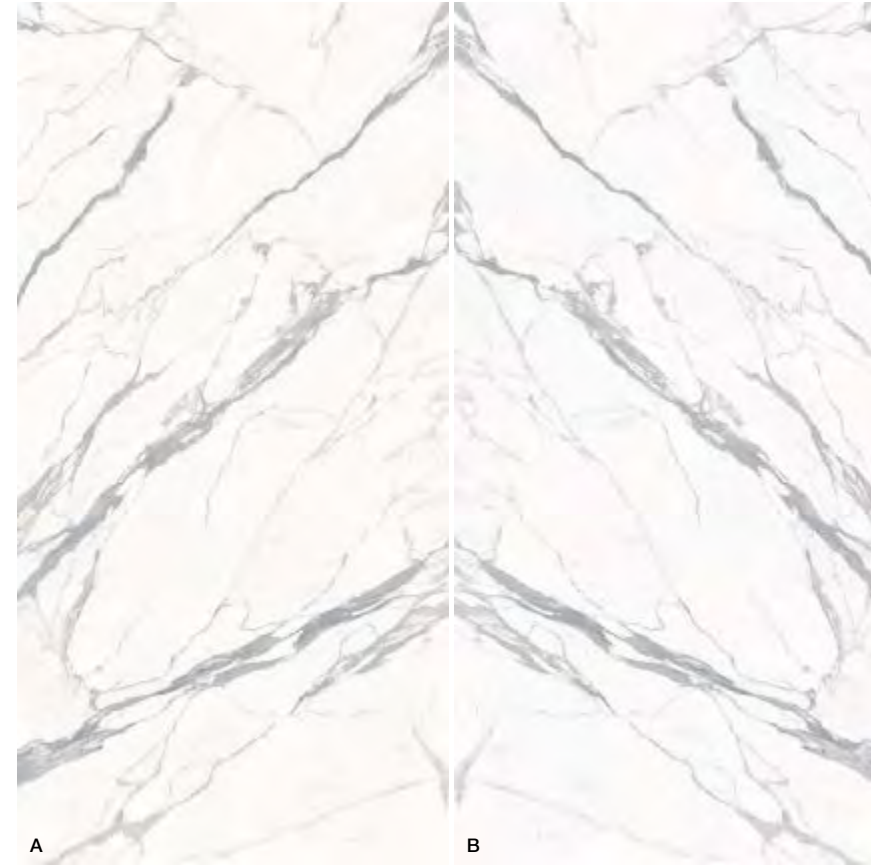

STATUARIO EXTRA

## LAYING EXAMPLE

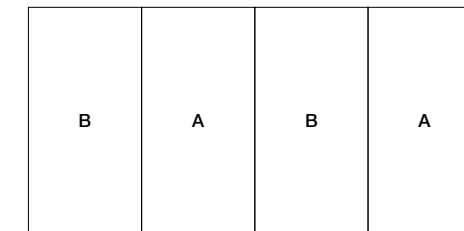
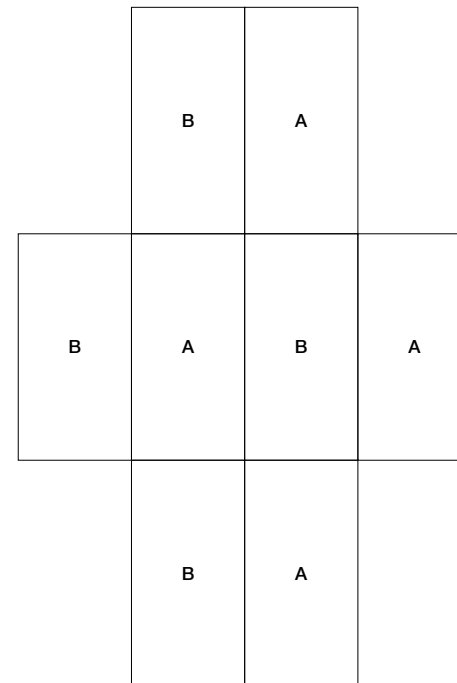

La grafica dello Statuario Extra Bookmatch consente di ricreare delle composizioni infinite perchè le venature combaciano sia verticalmente che orizzontalmente. Per ottenere questi effetti speculari, è importante seguire la successione delle lettere come nel disegno proposto. L'effetto Bookmatch tra le diverse lastre è soggetto alla tolleranza tipica del prodotto lapideo. | The aesthetic features of Statuario Extra Bookmatch allow users to recreate endless designs since the veining matches both horizontally and vertically. To ensure this seamless effect, it is important to follow the sequence of letters shown in the design given. The bookmatching effect created by placing different slabs together is subject to the usual joint specifications of stone tiles. | Le graphisme du Statuario Extra Bookmatch permet de recréer des compositions infinies parce que les veines coïncident verticalement et horizontalement. Pour obtenir ces effets spéculaire, il est important de suivre la succession des lettres d'après le dessin proposé. L'effet Bookmatch entre différentes dalles est soumis à la tolérance typique du produit en pierre. | Die Grafik des Statuario Extra Bookmatch ermöglicht die Bildung von unendlich vielen Zusammenstellungen, da die Aderungen sowohl vertikal als auch horizontal aneinander passen. Zur Erzielung dieser spiegelbildlichen Effekte ist es wichtig, die Buchstaben nacheinander auszuführen, wie in der vorgeschlagenen Zeichnung. Der Effekt des Bookmatching zwischen den verschiedenen Platten unterliegt der typischen Toleranz des Produktes aus Stein.



# infinito 2.0

REGISTERED DESIGN

GRAPHICS 120x278

210 INFINITO 2.0\_MARBLE EFFECT



STATUARIO EXTRA

211 INFINITO 2.0\_MARBLE EFFECT

Nel formato 120x278 lo "Statuario Extra" è prodotto in 5 differenti facce per accentuare l'effetto naturale tipico del marmo. In fase di approntamento dell'ordine, la selezione delle facce è random, pertanto la venatura continuativa fra i diversi pezzi non è garantita. Rispettare la successione raffigurata per ricreare la sincronizzazione. La prima lastra raffigurata si aggancia alla quinta per garantire una soluzione infinita. L'effetto vena continua fra i diversi pezzi è soggetta alla tolleranza tipica del prodotto lapideo. | In the 120x278 size, "Statuario Extra" is available with five different faces, to accentuate the natural look so typical of marble. When preparing the order, the different versions are chosen randomly, which means continuous veining between the different pieces is not guaranteed. Follow the sequence shown to recreate the synchronised effect. To ensure an endless finish, the sequence must be repeated continually, with the first slab placed after the fifth. The continuous veining effect across the various tiles is subject to the typical tolerance of stone products. | Dans le format 120x278 le "Statuario Extra" est produit en 5 faces différentes pour accentuer l'effet naturel typique du marbre. Au moment de la préparation de la commande,

la sélection des faces est fortuite ; la continuité des veines entre les différentes pièces n'est donc pas garantie. Respecter la succession représentée pour recréer la synchronisation. La première dalle représentée s'accroche à la cinquième pour garantir une solution infinie. L'effet de la veine continue entre les différentes pièces est soumis à la tolérance typique du produit en pierre. | Beim Format 120x278 wird der "Statuario Extra" in 5 verschiedenen Oberflächen hergestellt, um den natürlichen Effekt hervorzuheben, der für den Marmor typisch ist. Bei der Vorbereitung des Auftrags erfolgt die Auswahl der Oberflächen nach Zufall, weshalb die durchgehende Aderung zwischen den verschiedenen Teilen nicht garantiert ist. Halten Sie die dargestellte Reihenfolge ein, um die Synchronisierung nachzubilden. Die erste dargestellte Platte schließt sich an die fünfte an, um eine unendliche Lösung zu garantieren. Der Effekt der durchgehenden Aderung zwischen den verschiedenen Teilen unterliegt der typischen Toleranz des Produktes aus Stein.



# infinito 2.0

REGISTERED DESIGN

GRAPHICS 160x320



212 INFINITO 2.0\_MARBLE EFFECT

213 INFINITO 2.0\_MARBLE EFFECT

## STATUARIO EXTRA

Nel formato 160x320 lo "Statuario Extra" è prodotto in 4 differenti facce per accentuare l'effetto naturale tipico del marmo. In fase di approntamento dell'ordine, la selezione delle facce è random, pertanto la venatura continuativa fra i diversi pezzi non è garantita. Rispettare la successione raffigurata per ricreare la sincronizzazione. La prima lastra raffigurata si aggancia alla quarta per garantire una soluzione infinita. L'effetto vena continua fra i diversi pezzi è soggetta alla tolleranza tipica del prodotto lapideo. | In the 160x320 size, "Statuario Extra" is available with four different faces, to accentuate the natural look so typical of marble. When preparing the order, the different versions are chosen randomly, which means continuous veining between the different pieces is not guaranteed. Follow the sequence shown to recreate the synchronised effect. To ensure an endless finish, the sequence must be repeated continually, with the first slab placed after the fourth. The continuous veining effect across the various tiles is subject to the typical tolerance of stone products. | Dans le format 160x320 le "Statuario Extra" est produit en 4 faces différentes pour accentuer l'effet naturel typique du marbre. Au moment de la préparation de la commande, la sélection

des faces est fortuite ; la continuité des veines entre les différentes pièces n'est donc pas garantie. Respecter la succession représentée pour recréer la synchronisation. La première dalle représentée s'accroche à la quatrième pour garantir une solution infinie. L'effet de la veine continue entre les différentes pièces est soumis à la tolérance typique du produit en pierre. | Beim Format 160x320 wird der "Statuario Extra" in 4 verschiedenen Oberflächen hergestellt, um den natürlichen Effekt hervorzuheben, der für den Marmor typisch ist. Bei der Vorbereitung des Auftrags erfolgt die Auswahl der Oberflächen nach Zufall, weshalb die durchgehende Aderung zwischen den verschiedenen Teilen nicht garantiert ist. Halten Sie die dargestellte Reihenfolge ein, um die Synchronisierung nachzubilden. Die erste dargestellte Platte schließt sich an die vierte an, um eine unendliche Lösung zu garantieren. Der Effekt der durchgehenden Aderung zwischen den verschiedenen Teilen unterliegt der typischen Toleranz des Produktes aus Stein.



# infinito 2.0



214 INFINITO 2.0\_MARBLE EFFECT

## SIZES & SURFACES



**160x320\***  
62,99"x125,98"



**120x278\*\***  
47,24"x109,45"



**60x120**  
23,62"x47,24"

### 6,5 mm

**Glossy**  
Rettificato | Rectified |  
Rectifié | Rektifiziert

- **160x320** . 62,99"x125,98"  
**INF749**

**120x278** . 47,24"x109,45"  
**INF1156**

**60x120** . 23,62"x47,24"  
**INF864**

**Honed**  
Rettificato | Rectified |  
Rectifié | Rektifiziert

- **160x320** . 62,99"x125,98"  
**INF748**

**120x278** . 47,24"x109,45"  
**INF1155**

• Disponibile su richiesta | Available on request | Disponible sur demande |  
Auf Anfrage erhältlich

## STATUARIO

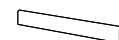

**6,5 mm**  
**8x120** . 3,15"x47,24"  
battiscopa  
**INF765** glossy



**6,5 mm**  
**33x120x5** . 12,99"x47,24"x1,97"  
gradino lineare LL  
**INF768** glossy



**6,5 mm**  
**33x120x5** . 12,99"x47,24"x1,97"  
gradino angolare LL  
**INF771** glossy

**Wall suggested grout**  
103 . Moon White



**Floor suggested grout**  
110 . Manhattan 2000

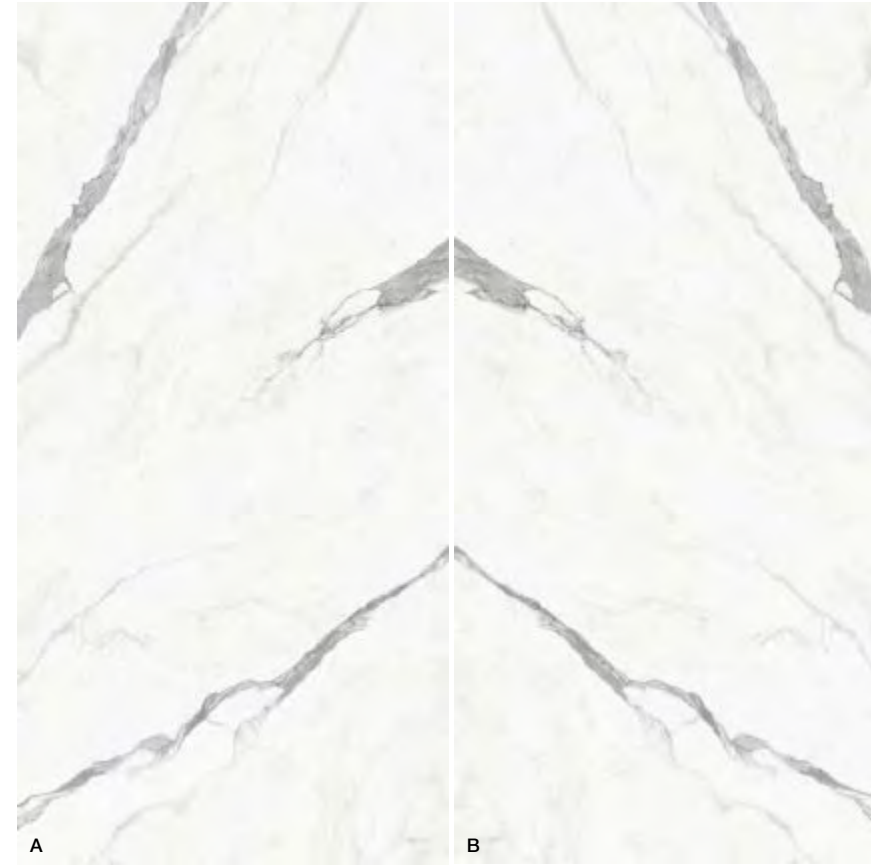

## STATUARIO

### LAYING EXAMPLE

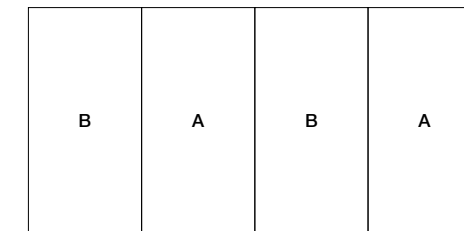
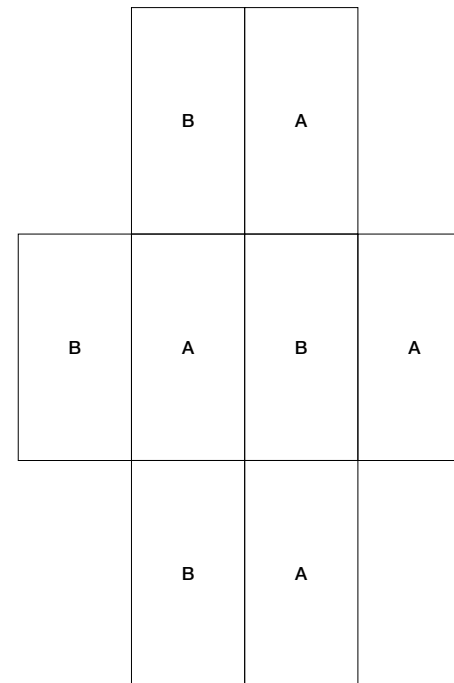

La grafica dello Statuario Bookmatch consente di ricreare delle composizioni infinite perchè le venature combaciano sia verticalmente che orizzontalmente. Per ottenere questi effetti speculari, è importante seguire la successione delle lettere come nel disegno proposto. L'effetto Bookmatch tra le diverse lastre è soggetto alla tolleranza tipica del prodotto lapideo. | The aesthetic features of Statuario Bookmatch allow users to recreate endless designs since the veining matches both horizontally and vertically. To ensure this seamless effect, it is important to follow the sequence of letters shown in the design given. The bookmatching effect created by placing different slabs together is subject to the usual joint specifications of stone tiles. | Le graphisme du Statuario Bookmatch permet de recréer des compositions infinies parce que les veines coïncident verticalement et horizontalement. Pour obtenir ces effets spéculaire, il est important de suivre la succession des lettres d'après le dessin proposé. L'effet Bookmatch entre différentes dalles est soumis à la tolérance typique du produit en pierre. | Die Grafik des Statuario Bookmatch ermöglicht die Bildung von unendlich vielen Zusammenstellungen, da die Aderungen sowohl vertikal als auch horizontal aneinander passen. Zur Erzielung dieser spiegelbildlichen Effekte ist es wichtig, die Buchstaben nacheinander auszuführen, wie in der vorgeschlagenen Zeichnung. Der Effekt des Bookmatching zwischen den verschiedenen Platten unterliegt der typischen Toleranz des Produktes aus Stein.

215 INFINITO 2.0\_MARBLE EFFECT



# infinito 2.0

GRAPHICS 120x278

216 INFINITO 2.0\_MARBLE EFFECT



STATUARIO

217 INFINITO 2.0\_MARBLE EFFECT

Nel formato 120x278 lo "Statuario" è prodotto in 5 differenti facce per accentuare l'effetto naturale tipico del marmo. In fase di approntamento dell'ordine, la selezione delle facce è random, pertanto la venatura continuativa fra i diversi pezzi non è garantita. Rispettare la successione raffigurata per ricreare la sincronizzazione. La prima lastra raffigurata si aggancia alla quinta per garantire una soluzione infinita. L'effetto vena continua fra i diversi pezzi è soggetto alla tolleranza tipica del prodotto lapideo. | In the 120x278 size, "Statuario" is available with five different faces, to accentuate the natural look so typical of marble. When preparing the order, the different versions are chosen randomly, which means continuous veining between the different pieces is not guaranteed. Follow the sequence shown to recreate the synchronised effect. To ensure an endless finish, the sequence must be repeated continually, with the first slab placed after the fifth. The continuous veining effect across the various tiles is subject to the typical tolerance of stone products. | Dans le format 120x278 le "Statuario" est produit en 5 faces différentes pour accentuer l'effet naturel typique du marbre. Au moment de la préparation de la commande,

la sélection des faces est fortuite ; la continuité des veines entre les différentes pièces n'est donc pas garantie. Respecter la succession représentée pour recréer la synchronisation. La première dalle représentée s'accroche à la cinquième pour garantir une solution infinie. L'effet de la veine continue entre les différentes pièces est soumis à la tolérance typique du produit en pierre. | Beim Format 120x278 wird der "Statuario" in 5 verschiedenen Oberflächen hergestellt, um den natürlichen Effekt hervorzuheben, der für den Marmor typisch ist. Bei der Vorbereitung des Auftrags erfolgt die Auswahl der Oberflächen nach Zufall, weshalb die durchgehende Aderung zwischen den verschiedenen Teilen nicht garantiert ist. Halten Sie die dargestellte Reihenfolge ein, um die Synchronisierung nachzubilden. Die erste dargestellte Platte schließt sich an die fünfte an, um eine unendliche Lösung zu garantieren. Der Effekt der durchgehenden Aderung zwischen den verschiedenen Teilen unterliegt der typischen Toleranz des Produktes aus Stein.



# infinito 2.0

GRAPHICS 160x320



218 INFINITO 2.0\_MARBLE EFFECT

219 INFINITO 2.0\_MARBLE EFFECT

## STATUARIO

Nel formato 160x320 lo "Statuario" è prodotto in 4 differenti facce per accentuare l'effetto naturale tipico del marmo. In fase di approntamento dell'ordine, la selezione delle facce è random, pertanto la venatura continuativa fra i diversi pezzi non è garantita. Rispettare la successione raffigurata per ricreare la sincronizzazione. La prima lastra raffigurata si aggancia alla quarta per garantire una soluzione infinita. L'effetto vena continua fra i diversi pezzi è soggetta alla tolleranza tipica del prodotto lapideo. | In the 160x320 size, "Statuario" is available with four different faces, to accentuate the natural look so typical of marble. When preparing the order, the different versions are chosen randomly, which means continuous veining between the different pieces is not guaranteed. Follow the sequence shown to recreate the synchronised effect. To ensure an endless finish, the sequence must be repeated continually, with the first slab placed after the fourth. The continuous veining effect across the various tiles is subject to the typical tolerance of stone products. | Dans le format 160x320 le "Statuario" est produit en 4 faces différentes pour accentuer l'effet naturel typique du marbre. Au moment de la préparation de la commande, la sélection des faces est fortuite ; la

continuité des veines entre les différentes pièces n'est donc pas garantie. Respecter la succession représentée pour recréer la synchronisation. La première dalle représentée s'accroche à la quatrième pour garantir une solution infinie. L'effet de la veine continue entre les différentes pièces est soumis à la tolérance typique du produit en pierre. | Beim Format 160x320 wird der "Statuario" in 4 verschiedenen Oberflächen hergestellt, um den natürlichen Effekt hervorzuheben, der für den Marmor typisch ist. Bei der Vorbereitung des Auftrags erfolgt die Auswahl der Oberflächen nach Zufall, weshalb die durchgehende Aderung zwischen den verschiedenen Teilen nicht garantiert ist. Halten Sie die dargestellte Reihenfolge ein, um die Synchronisierung nachzubilden. Die erste dargestellte Platte schließt sich an die vierte an, um eine unendliche Lösung zu garantieren. Der Effekt der durchgehenden Aderung zwischen den verschiedenen Teilen unterliegt der typischen Toleranz des Produktes aus Stein.





# infinito 2.0

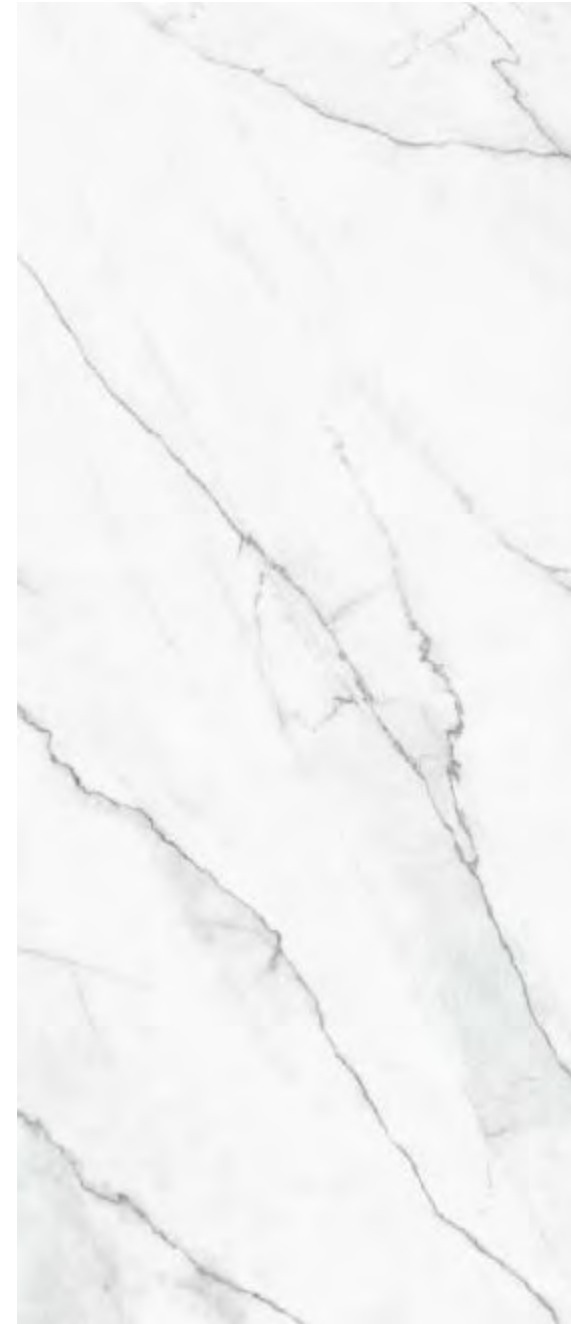

SIZES & SURFACES



**160x320\***  
62,99"x125,98"



**120x278\*\***  
47,24"x109,45"



**60x120**  
23,62"x47,24"

**6,5 mm**

**Glossy**  
Rettificato | Rectified |  
Rectifié | Rektifiziert

- **160x320** . 62,99"x125,98"  
**INF467**

**120x278** . 47,24"x109,45"  
**INF1153**

**60x120** . 23,62"x47,24"  
**INF824**

**Honed**  
Rettificato | Rectified |  
Rectifié | Rektifiziert

- **160x320** . 62,99"x125,98"  
**INF466**

**120x278** . 47,24"x109,45"  
**INF1152**

• Disponibile su richiesta | Available on request | Disponible sur demande |  
Auf Anfrage erhältlich

**LINCOLN**

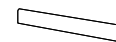

**6,5 mm**  
**8x120** . 3,15"x47,24"  
battiscopa  
**INF318** glossy

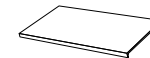

**6,5 mm**  
**33x120x5** . 12,99"x47,24"x1,97"  
gradino lineare LL  
**INF596** glossy

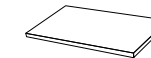

**6,5 mm**  
**33x120x5** . 12,99"x47,24"x1,97"  
gradino angolare LL  
**INF598** glossy

**Wall suggested grout**  
103 . Moon White



**Floor suggested grout**  
110 . Manhattan 2000





# infinito 2.0

GRAPHICS 120x278

222 INFINITO 2.0\_MARBLE EFFECT



LINCOLN

223 INFINITO 2.0\_MARBLE EFFECT

Nel formato 120x278 il "Lincoln" è prodotto in 5 differenti facce per accentuare l'effetto naturale tipico del marmo. In fase di approntamento dell'ordine, la selezione delle facce è random, pertanto la venatura continuativa fra i diversi pezzi non è garantita. Rispettare la successione raffigurata per ricreare la sincronizzazione. La prima lastra raffigurata si aggancia alla quinta per garantire una soluzione infinita. L'effetto vena continua fra i diversi pezzi è soggetta alla tolleranza tipica del prodotto lapideo. | In the 120x278 size, "Lincoln" is available with five different faces, to accentuate the natural look so typical of marble. When preparing the order, the different versions are chosen randomly, which means continuous veining between the different pieces is not guaranteed. Follow the sequence shown to recreate the synchronised effect. To ensure an endless finish, the sequence must be repeated continually, with the first slab placed after the fifth. The continuous veining effect across the various tiles is subject to the typical tolerance of stone products. | Dans le format 120x278 le "Lincoln" est produit en 5 faces différentes pour accentuer l'effet naturel typique du marbre. Au moment de la préparation de la commande, la

sélection des faces est fortuite ; la continuité des veines entre les différentes pièces n'est donc pas garantie. Respecter la succession représentée pour recréer la synchronisation. La première dalle représentée s'accroche à la cinquième pour garantir une solution infinie. L'effet de la veine continue entre les différentes pièces est soumis à la tolérance typique du produit en pierre. | Beim Format 120x278 wird der "Lincoln" in 5 verschiedenen Oberflächen hergestellt, um den natürlichen Effekt hervorzuheben, der für den Marmor typisch ist. Bei der Vorbereitung des Auftrags erfolgt die Auswahl der Oberflächen nach Zufall, weshalb die durchgehende Aderung zwischen den verschiedenen Teilen nicht garantiert ist. Halten Sie die dargestellte Reihenfolge ein, um die Synchronisierung nachzubilden. Die erste dargestellte Platte schließt sich an die fünfte an, um eine unendliche Lösung zu garantieren. Der Effekt der durchgehenden Aderung zwischen den verschiedenen Teilen unterliegt der typischen Toleranz des Produktes aus Stein.



# infinito 2.0

GRAPHICS 160x320



224 INFINITO 2.0\_MARBLE EFFECT

225 INFINITO 2.0\_MARBLE EFFECT

## LINCOLN

Nel formato 160x320 il "Lincoln" è prodotto in 4 differenti facce per accentuare l'effetto naturale tipico del marmo. In fase di approntamento dell'ordine, la selezione delle facce è random, pertanto la venatura continuativa fra i diversi pezzi non è garantita. Rispettare la successione raffigurata per ricreare la sincronizzazione. La prima lastra raffigurata si aggancia alla quarta per garantire una soluzione infinita. L'effetto vena continua fra i diversi pezzi è soggetta alla tolleranza tipica del prodotto lapideo. | In the 160x320 size, "Lincoln" is available with four different faces, to accentuate the natural look so typical of marble. When preparing the order, the different versions are chosen randomly, which means continuous veining between the different pieces is not guaranteed. Follow the sequence shown to recreate the synchronised effect. To ensure an endless finish, the sequence must be repeated continually, with the first slab placed after the fourth. The continuous veining effect across the various tiles is subject to the typical tolerance of stone products. | Dans le format 160x320 le "Lincoln" est produit en 4 faces différentes pour accentuer l'effet naturel typique du marbre. Au moment de la préparation de la commande, la sélection des faces est fortuite ; la continuité

des veines entre les différentes pièces n'est donc pas garantie. Respecter la succession représentée pour recréer la synchronisation. La première dalle représentée s'accroche à la quatrième pour garantir une solution infinie. L'effet de la veine continue entre les différentes pièces est soumis à la tolérance typique du produit en pierre. | Beim Format 160x320 wird der "Lincoln" in 4 verschiedenen Oberflächen hergestellt, um den natürlichen Effekt hervorzuheben, der für den Marmor typisch ist. Bei der Vorbereitung des Auftrags erfolgt die Auswahl der Oberflächen nach Zufall, weshalb die durchgehende Aderung zwischen den verschiedenen Teilen nicht garantiert ist. Halten Sie die dargestellte Reihenfolge ein, um die Synchronisierung nachzubilden. Die erste dargestellte Platte schließt sich an die vierte an, um eine unendliche Lösung zu garantieren. Der Effekt der durchgehenden Aderung zwischen den verschiedenen Teilen unterliegt der typischen Toleranz des Produktes aus Stein.



# infinito 2.0



226 INFINITO 2.0\_MARBLE EFFECT

## SIZES & SURFACES



**160x320\***  
62,99"x125,98"



**120x278\*\***  
47,24"x109,45"



**60x120**  
23,62"x47,24"

### 6,5 mm

**Glossy**  
Rettificato | Rectified |  
Rectifié | Rektifiziert

- **160x320** . 62,99"x125,98"  
**INF416**

**120x278** . 47,24"x109,45"  
**INF1183**

**60x120** . 23,62"x47,24"  
**INF818**

**Honed**  
Rettificato | Rectified |  
Rectifié | Rektifiziert

- **160x320** . 62,99"x125,98"  
**INF415**

**120x278** . 47,24"x109,45"  
**INF1182**

- Disponibile su richiesta | Available on request | Disponible sur demande | Auf Anfrage erhältlich

## CALACATTA WHITE

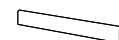

**6,5 mm**  
**8x120** . 3,15"x47,24"  
battiscopa  
**INF698** glossy



**6,5 mm**  
**33x120x5** . 12,99"x47,24"x1,97"  
gradino lineare LL  
**INF591** glossy



**6,5 mm**  
**33x120x5** . 12,99"x47,24"x1,97"  
gradino angolare LL  
**INF593** glossy

**Wall suggested grout**  
103 . Moon White



**Floor suggested grout**  
110 . Manhattan 2000

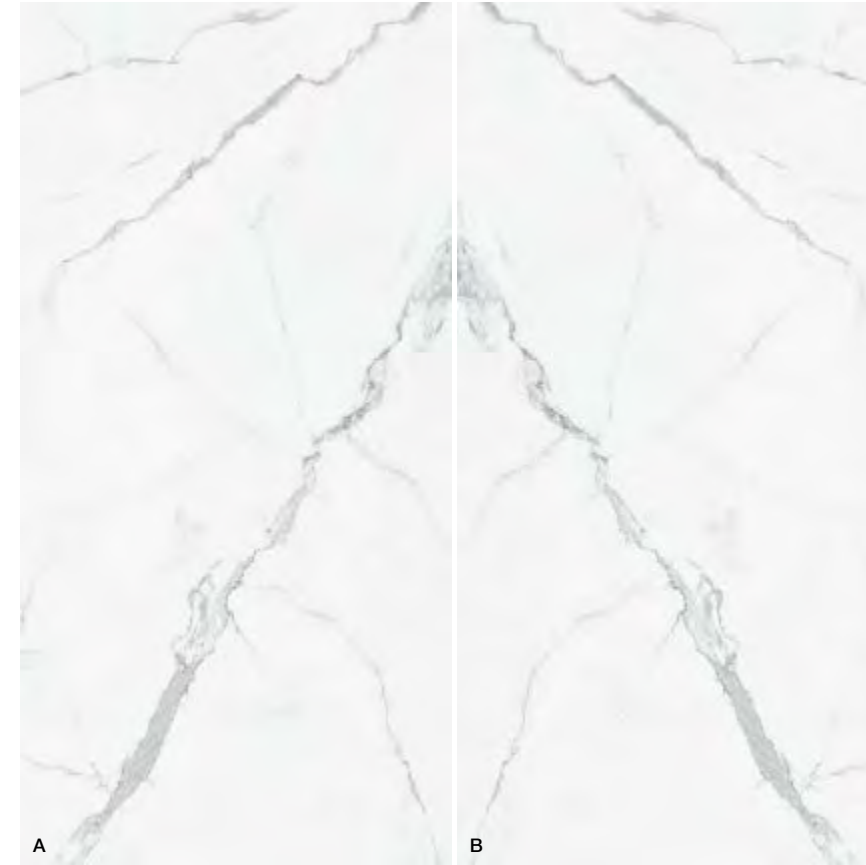

## CALACATTA WHITE

### LAYING EXAMPLE

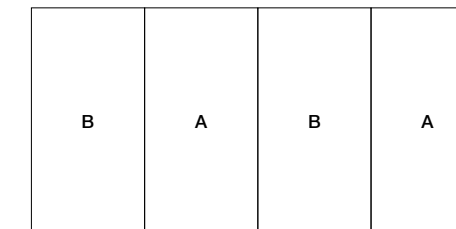
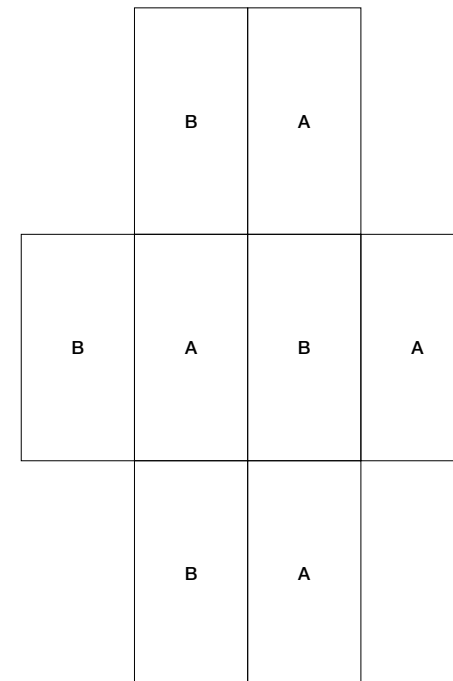

La grafica del Calacatta White Bookmatch consente di ricreare delle composizioni infinite perchè le venature combaciano sia verticalmente che orizzontalmente. Per ottenere questi effetti speculari, è importante seguire la successione delle lettere come nel disegno proposto. L'effetto Bookmatch tra le diverse lastre è soggetto alla tolleranza tipica del prodotto lapideo. | The aesthetic features of Calacatta White Bookmatch allow users to recreate endless designs since the veining matches both horizontally and vertically. To ensure this seamless effect, it is important to follow the sequence of letters shown in the design given. The bookmatching effect created by placing different slabs together is subject to the usual joint specifications of stone tiles. | Le graphisme du Calacatta White Bookmatch permet de recréer des compositions infinies parce que les veines coïncident verticalement et horizontalement. Pour obtenir ces effets spéculaire, il est important de suivre la succession des lettres d'après le dessin proposé. L'effet Bookmatch entre différentes dalles est soumis à la tolérance typique du produit en pierre. | Die Grafik des Calacatta White Bookmatch ermöglicht die Bildung von unendlich vielen Zusammenstellungen, da die Aderungen sowohl vertikal als auch horizontal aneinander passen. Zur Erzielung dieser spiegelbildlichen Effekte ist es wichtig, die Buchstaben nacheinander auszuführen, wie in der vorgeschlagenen Zeichnung. Der Effekt des Bookmatching zwischen den verschiedenen Platten unterliegt der typischen Toleranz des Produktes aus Stein.

227 INFINITO 2.0\_MARBLE EFFECT



# infinito 2.0

GRAPHICS 120x278



CALACATTA WHITE

228 INFINITO 2.0\_MARBLE EFFECT

229 INFINITO 2.0\_MARBLE EFFECT

Nel formato 120x278 il "Calacatta White" è prodotto in 5 differenti facce per accentuare l'effetto naturale tipico del marmo. In fase di approntamento dell'ordine, la selezione delle facce è random, pertanto la venatura continuativa fra i diversi pezzi non è garantita. Rispettare la successione raffigurata per ricreare la sincronizzazione. La prima lastra raffigurata si aggancia alla quinta per garantire una soluzione infinita. L'effetto vena continua fra i diversi pezzi è soggetto alla tolleranza tipica del prodotto lapideo. | In the 120x278 size, "Calacatta White" is available with five different faces, to accentuate the natural look so typical of marble. When preparing the order, the different versions are chosen randomly, which means continuous veining between the different pieces is not guaranteed. Follow the sequence shown to recreate the synchronised effect. To ensure an endless finish, the sequence must be repeated continually, with the first slab placed after the fifth. The continuous veining effect across the various tiles is subject to the typical tolerance of stone products. | Dans le format 120x278 le "Calacatta White" est produit en 5 faces différentes pour accentuer l'effet naturel typique du marbre. Au moment de la préparation

de la commande, la sélection des faces est fortuite ; la continuité des veines entre les différentes pièces n'est donc pas garantie. Respecter la succession représentée pour recréer la synchronisation. La première dalle représentée s'accroche à la cinquième pour garantir une solution infinie. L'effet de la veine continue entre les différentes pièces est soumis à la tolérance typique du produit en pierre. | Beim Format 120x278 wird der "Calacatta White" in 5 verschiedenen Oberflächen hergestellt, um den natürlichen Effekt hervorzuheben, der für den Marmor typisch ist. Bei der Vorbereitung des Auftrags erfolgt die Auswahl der Oberflächen nach Zufall, weshalb die durchgehende Aderung zwischen den verschiedenen Teilen nicht garantiert ist. Halten Sie die dargestellte Reihenfolge ein, um die Synchronisierung nachzubilden. Die erste dargestellte Platte schließt sich an die fünfte an, um eine unendliche Lösung zu garantieren. Der Effekt der durchgehenden Aderung zwischen den verschiedenen Teilen unterliegt der typischen Toleranz des Produktes aus Stein.



# infinito 2.0

GRAPHICS 160x320



230 INFINITO 2.0\_MARBLE EFFECT

231 INFINITO 2.0\_MARBLE EFFECT

## CALACATTA WHITE

Nel formato 160x320 il "Calacatta White" è prodotto in 4 differenti facce per accentuare l'effetto naturale tipico del marmo. In fase di approntamento dell'ordine, la selezione delle facce è random, pertanto la venatura continuativa fra i diversi pezzi non è garantita. Rispettare la successione raffigurata per ricreare la sincronizzazione. La prima lastra raffigurata si aggancia alla quarta per garantire una soluzione infinita. L'effetto vena continua fra i diversi pezzi è soggetta alla tolleranza tipica del prodotto lapideo. | In the 160x320 size, "Calacatta White" is available with four different faces, to accentuate the natural look so typical of marble. When preparing the order, the different versions are chosen randomly, which means continuous veining between the different pieces is not guaranteed. Follow the sequence shown to recreate the synchronised effect. To ensure an endless finish, the sequence must be repeated continually, with the first slab placed after the fourth. The continuous veining effect across the various tiles is subject to the typical tolerance of stone products. | Dans le format 160x320 le "Calacatta White" est produit en 4 faces différentes pour accentuer l'effet naturel typique du marbre. Au moment de la préparation de la commande, la sélection

des faces est fortuite ; la continuité des veines entre les différentes pièces n'est donc pas garantie. Respecter la succession représentée pour recréer la synchronisation. La première dalle représentée s'accroche à la quatrième pour garantir une solution infinie. L'effet de la veine continue entre les différentes pièces est soumis à la tolérance typique du produit en pierre. | Beim Format 160x320 wird der "Calacatta White" in 4 verschiedenen Oberflächen hergestellt, um den natürlichen Effekt hervorzuheben, der für den Marmor typisch ist. Bei der Vorbereitung des Auftrags erfolgt die Auswahl der Oberflächen nach Zufall, weshalb die durchgehende Aderung zwischen den verschiedenen Teilen nicht garantiert ist. Halten Sie die dargestellte Reihenfolge ein, um die Synchronisierung nachzubilden. Die erste dargestellte Platte schließt sich an die vierte an, um eine unendliche Lösung zu garantieren. Der Effekt der durchgehenden Aderung zwischen den verschiedenen Teilen unterliegt der typischen Toleranz des Produktes aus Stein.



# infinito 2.0

REGISTERED DESIGN

## SIZES & SURFACES



**160x320\***  
62,99"x125,98"



**120x278\*\***  
47,24"x109,45"



**60x120**  
23,62"x47,24"

### 6,5 mm

**Glossy**  
Rettificato | Rectified |  
Rectifié | Rektifiziert

- **160x320** . 62,99"x125,98"  
**INF1300**

**120x278** . 47,24"x109,45"  
**INF1281**

**60x120** . 23,62"x47,24"  
**INF1534**

**Honed**  
Rettificato | Rectified |  
Rectifié | Rektifiziert

- **160x320** . 62,99"x125,98"  
**INF1299**

**120x278** . 47,24"x109,45"  
**INF1280**

- Disponibile su richiesta | Available on request | Disponible sur demande | Auf Anfrage erhältlich

**Wall suggested grout**  
103 . Moon White



**Floor suggested grout**  
110 . Manhattan 2000



CALACATTA LIGHT

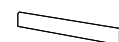

**6,5 mm**  
**8x120** . 3,15"x47,24"  
battiscopa  
**INF1312** glossy



**6,5 mm**  
**33x120x5** . 12,99"x47,24"x1,97"  
gradino lineare LL  
**INF1315** glossy



**6,5 mm**  
**33x120x5** . 12,99"x47,24"x1,97"  
gradino angolare LL  
**INF1318** glossy



CALACATTA LIGHT

## LAYING EXAMPLE

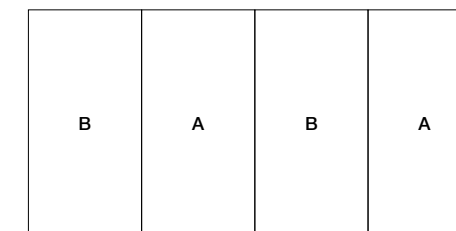
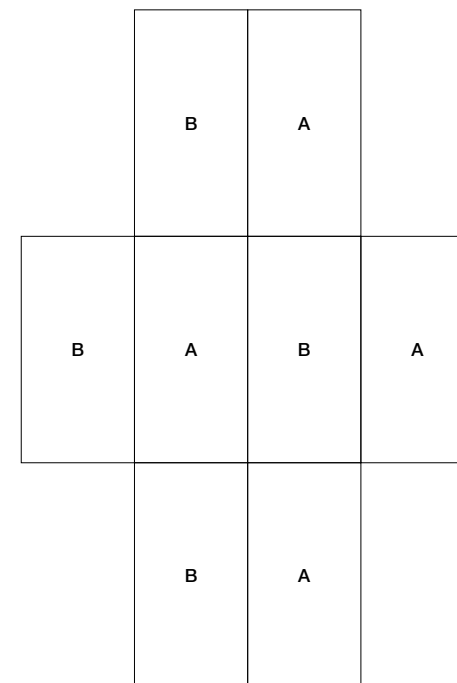

La grafica del Calacatta Light Bookmatch consente di ricreare delle composizioni infinite perchè le venature combaciano sia verticalmente che orizzontalmente. Per ottenere questi effetti speculari, è importante seguire la successione delle lettere come nel disegno proposto. L'effetto Bookmatch tra le diverse lastre è soggetto alla tolleranza tipica del prodotto lapideo. | The aesthetic features of Calacatta Light Bookmatch allow users to recreate endless designs since the veining matches both horizontally and vertically. To ensure this seamless effect, it is important to follow the sequence of letters shown in the design given. The bookmatching effect created by placing different slabs together is subject to the usual joint specifications of stone tiles. | Le graphisme du Calacatta Light Bookmatch permet de recréer des compositions infinies parce que les veines coïncident verticalement et horizontalement. Pour obtenir ces effets spéculaire, il est important de suivre la succession des lettres d'après le dessin proposé. L'effet Bookmatch entre différentes dalles est soumis à la tolérance typique du produit en pierre. | Die Grafik des Calacatta Light Bookmatch ermöglicht die Bildung von unendlich vielen Zusammenstellungen, da die Aderungen sowohl vertikal als auch horizontal aneinander passen. Zur Erzielung dieser spiegelbildlichen Effekte ist es wichtig, die Buchstaben nacheinander auszuführen, wie in der vorgeschlagenen Zeichnung. Der Effekt des Bookmatching zwischen den verschiedenen Platten unterliegt der typischen Toleranz des Produktes aus Stein.



# infinito 2.0

REGISTERED DESIGN

GRAPHICS 120x278



234 INFINITO 2.0\_MARBLE EFFECT

235 INFINITO 2.0\_MARBLE EFFECT

CALACATTA LIGHT

Nel formato 120x278 il "Calacatta Light" è prodotto in 5 differenti facce per accentuare l'effetto naturale tipico del marmo. In fase di approntamento dell'ordine, la selezione delle facce è random, pertanto la venatura continuativa fra i diversi pezzi non è garantita. Rispettare la successione raffigurata per ricreare la sincronizzazione. La prima lastra raffigurata si aggancia alla quinta per garantire una soluzione infinita. L'effetto vena continua fra i diversi pezzi è soggetta alla tolleranza tipica del prodotto lapideo. | In the 120x278 size, "Calacatta Light" is available with five different faces, to accentuate the natural look so typical of marble. When preparing the order, the different versions are chosen randomly, which means continuous veining between the different pieces is not guaranteed. Follow the sequence shown to recreate the synchronised effect. To ensure an endless finish, the sequence must be repeated continually, with the first slab placed after the fifth. The continuous veining effect across the various tiles is subject to the typical tolerance of stone products. | Dans le format 120x278 le "Calacatta Light" est produit en 5 faces différentes pour accentuer l'effet naturel typique du marbre. Au moment de la préparation de

la commande, la sélection des faces est fortuite ; la continuité des veines entre les différentes pièces n'est donc pas garantie. Respecter la succession représentée pour recréer la synchronisation. La première dalle représentée s'accroche à la cinquième pour garantir une solution infinie. L'effet de la veine continue entre les différentes pièces est soumis à la tolérance typique du produit en pierre. | Beim Format 120x278 wird der "Calacatta Light" in 5 verschiedenen Oberflächen hergestellt, um den natürlichen Effekt hervorzuheben, der für den Marmor typisch ist. Bei der Vorbereitung des Auftrags erfolgt die Auswahl der Oberflächen nach Zufall, weshalb die durchgehende Aderung zwischen den verschiedenen Teilen nicht garantiert ist. Halten Sie die dargestellte Reihenfolge ein, um die Synchronisierung nachzubilden. Die erste dargestellte Platte schließt sich an die fünfte an, um eine unendliche Lösung zu garantieren. Der Effekt der durchgehenden Aderung zwischen den verschiedenen Teilen unterliegt der typischen Toleranz des Produktes aus Stein.



# infinito 2.0

REGISTERED DESIGN

GRAPHICS 160x320



236 INFINITO 2.0\_MARBLE EFFECT

237 INFINITO 2.0\_MARBLE EFFECT

## CALACATTA LIGHT

Nel formato 160x320 il "Calacatta Light" è prodotto in 4 differenti facce per accentuare l'effetto naturale tipico del marmo. In fase di approntamento dell'ordine, la selezione delle facce è random, pertanto la venatura continuativa fra i diversi pezzi non è garantita. Rispettare la successione raffigurata per ricreare la sincronizzazione. La prima lastra raffigurata si aggancia alla quarta per garantire una soluzione infinita. L'effetto vena continua fra i diversi pezzi è soggetta alla tolleranza tipica del prodotto lapideo. | In the 160x320 size, "Calacatta Light" is available with four different faces, to accentuate the natural look so typical of marble. When preparing the order, the different versions are chosen randomly, which means continuous veining between the different pieces is not guaranteed. Follow the sequence shown to recreate the synchronised effect. To ensure an endless finish, the sequence must be repeated continually, with the first slab placed after the fourth. The continuous veining effect across the various tiles is subject to the typical tolerance of stone products. | Dans le format 160x320 le "Calacatta Light" est produit en 4 faces différentes pour accentuer l'effet naturel typique du marbre. Au moment de la préparation de la commande, la sélection

des faces est fortuite ; la continuité des veines entre les différentes pièces n'est donc pas garantie. Respecter la succession représentée pour recréer la synchronisation. La première dalle représentée s'accroche à la quatrième pour garantir une solution infinie. L'effet de la veine continue entre les différentes pièces est soumis à la tolérance typique du produit en pierre. | Beim Format 160x320 wird der "Calacatta Light" in 4 verschiedenen Oberflächen hergestellt, um den natürlichen Effekt hervorzuheben, der für den Marmor typisch ist. Bei der Vorbereitung des Auftrags erfolgt die Auswahl der Oberflächen nach Zufall, weshalb die durchgehende Aderung zwischen den verschiedenen Teilen nicht garantiert ist. Halten Sie die dargestellte Reihenfolge ein, um die Synchronisierung nachzubilden. Die erste dargestellte Platte schließt sich an die vierte an, um eine unendliche Lösung zu garantieren. Der Effekt der durchgehenden Aderung zwischen den verschiedenen Teilen unterliegt der typischen Toleranz des Produktes aus Stein.





# infinito 2.0

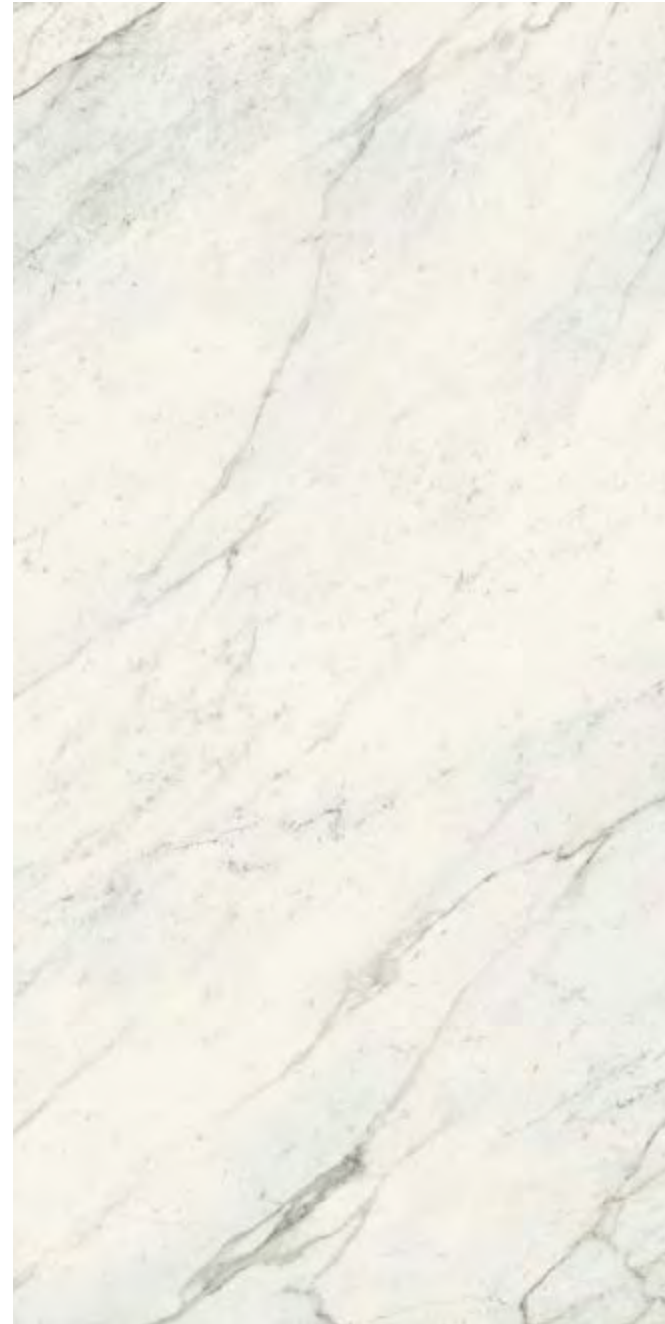

ELEGANT WHITE

SIZES & SURFACES



160x320\*  
62,99"x125,98"

**6,5 mm**

**Natural**  
Rettificato | Rectified |  
Rectifié | Rektifiziert

- 160x320 . 62,99"x125,98"  
**INF2192**

• Disponibile su richiesta | Available on request | Disponible sur demande |  
Auf Anfrage erhältlich

**Wall suggested grout**  
103 . Moon White



**Floor suggested grout**  
110 . Manhattan 2000





# infinito 2.0

GRAPHICS 160x320

240 INFINITO 2.0\_MARBLE EFFECT



1

ELEGANT WHITE



2



3

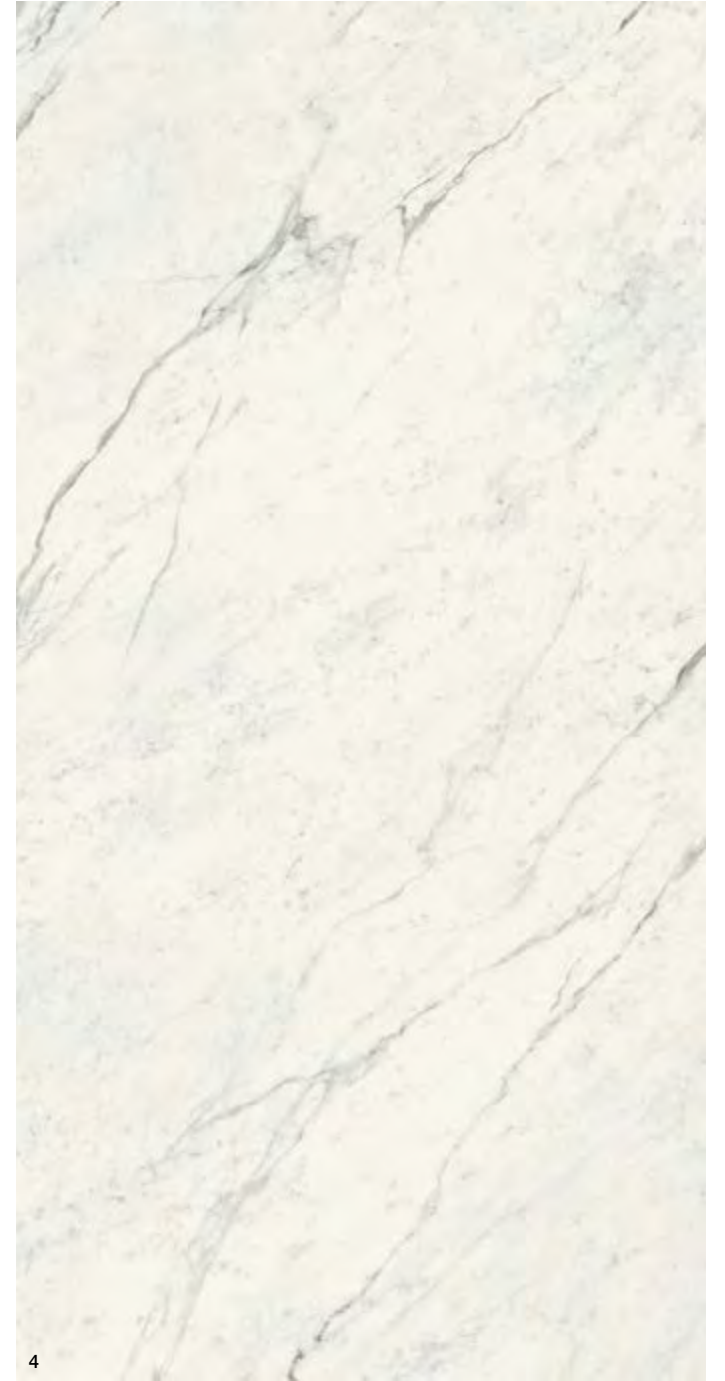

4

241 INFINITO 2.0\_MARBLE EFFECT

160x320\_Prodotto con 4 diverse grafiche confezionate in modo casuale | Produced with a variety of a range of 4 different graphic designs which are randomly combined and then packed | Produit avec 4 différents graphismes conditionnés de façon fortuite | Mit 4 unterschiedlichen Graphiken hergestellt und mit einer zufälliger Auswahl verpackt



# infinito 2.0



242 INFINITO 2.0\_MARBLE EFFECT

## SIZES & SURFACES



**160x320\***  
62,99"x125,98"



**120x278\*\***  
47,24"x109,45"



**60x120**  
23,62"x47,24"

### 6,5 mm

**Glossy**  
Rettificato | Rectified |  
Rectifié | Rektifiziert

- **160x320** . 62,99"x125,98"  
**INF501**

**120x278** . 47,24"x109,45"  
**INF1174**

**60x120** . 23,62"x47,24"  
**INF821**

**Honed**  
Rettificato | Rectified |  
Rectifié | Rektifiziert

- **160x320** . 62,99"x125,98"  
**INF500**

**120x278** . 47,24"x109,45"  
**INF1173**

**Natural**  
Rettificato | Rectified |  
Rectifié | Rektifiziert

**120x278** . 47,24"x109,45"  
**INF1917**

- Disponibile su richiesta | Available on request | Disponible sur demande | Auf Anfrage erhältlich

## CALACATTA GOLD

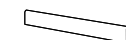

**6,5 mm**  
**8x120** . 3,15"x47,24"  
battiscopa  
**INF610** glossy



**6,5 mm**  
**33x120x5** . 12,99"x47,24"x1,97"  
gradino lineare LL  
**INF613** glossy



**6,5 mm**  
**33x120x5** . 12,99"x47,24"x1,97"  
gradino angolare LL  
**INF616** glossy

**Suggested grout**  
130 . Jasmine



## CALACATTA GOLD

### LAYING EXAMPLE

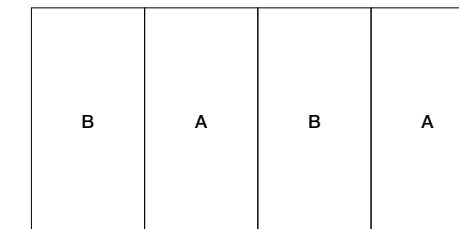
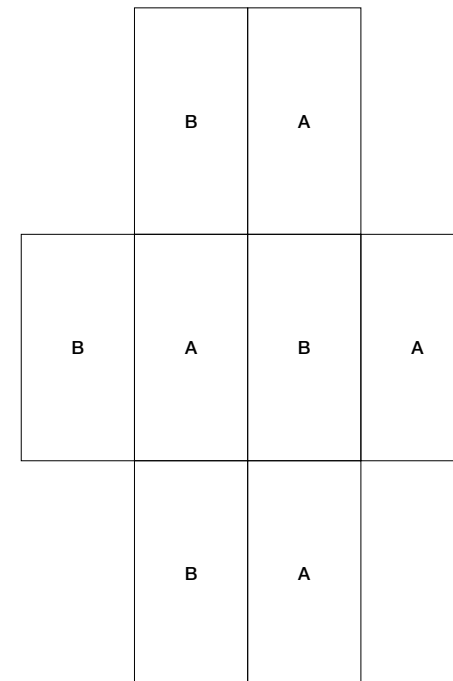

La grafica del Calacatta Gold Bookmatch consente di ricreare delle composizioni infinite perchè le venature combaciano sia verticalmente che orizzontalmente. Per ottenere questi effetti speculari, è importante seguire la successione delle lettere come nel disegno proposto. L'effetto Bookmatch tra le diverse lastre è soggetto alla tolleranza tipica del prodotto lapideo. | The aesthetic features of Calacatta Gold Bookmatch allow users to recreate endless designs since the veining matches both horizontally and vertically. To ensure this seamless effect, it is important to follow the sequence of letters shown in the design given. The bookmatching effect created by placing different slabs together is subject to the usual joint specifications of stone tiles. | Le graphisme du Calacatta Gold Bookmatch permet de recréer des compositions infinies parce que les veines coïncident verticalement et horizontalement. Pour obtenir ces effets spéculaire, il est important de suivre la succession des lettres d'après le dessin proposé. L'effet Bookmatch entre différentes dalles est soumis à la tolérance typique du produit en pierre. | Die Grafik des Calacatta Gold Bookmatch ermöglicht die Bildung von unendlich vielen Zusammenstellungen, da die Aderungen sowohl vertikal als auch horizontal aneinander passen. Zur Erzielung dieser spiegelbildlichen Effekte ist es wichtig, die Buchstaben nacheinander auszuführen, wie in der vorgeschlagenen Zeichnung. Der Effekt des Bookmatching zwischen den verschiedenen Platten unterliegt der typischen Toleranz des Produktes aus Stein.

243 INFINITO 2.0\_MARBLE EFFECT



# infinito 2.0

GRAPHICS 120x278



244 INFINITO 2.0\_MARBLE EFFECT

245 INFINITO 2.0\_MARBLE EFFECT

CALACATTA GOLD

Nel formato 120x278 il "Calacatta Gold" è prodotto in 5 differenti facce per accentuare l'effetto naturale tipico del marmo. In fase di approntamento dell'ordine, la selezione delle facce è random, pertanto la venatura continuativa fra i diversi pezzi non è garantita. Rispettare la successione raffigurata per ricreare la sincronizzazione. La prima lastra raffigurata si aggancia alla quinta per garantire una soluzione infinita. L'effetto vena continua fra i diversi pezzi è soggetta alla tolleranza tipica del prodotto lapideo. | In the 120x278 size, "Calacatta Gold" is available with five different faces, to accentuate the natural look so typical of marble. When preparing the order, the different versions are chosen randomly, which means continuous veining between the different pieces is not guaranteed. Follow the sequence shown to recreate the synchronised effect. To ensure an endless finish, the sequence must be repeated continually, with the first slab placed after the fifth. The continuous veining effect across the various tiles is subject to the typical tolerance of stone products. | Dans le format 120x278 le "Calacatta Gold" est produit en 5 faces différentes pour accentuer l'effet naturel typique du marbre. Au moment de la préparation de

la commande, la sélection des faces est fortuite ; la continuité des veines entre les différentes pièces n'est donc pas garantie. Respecter la succession représentée pour recréer la synchronisation. La première dalle représentée s'accroche à la cinquième pour garantir une solution infinie. L'effet de la veine continue entre les différentes pièces est soumis à la tolérance typique du produit en pierre. | Beim Format 120x278 wird der "Calacatta Gold" in 5 verschiedenen Oberflächen hergestellt, um den natürlichen Effekt hervorzuheben, der für den Marmor typisch ist. Bei der Vorbereitung des Auftrags erfolgt die Auswahl der Oberflächen nach Zufall, weshalb die durchgehende Aderung zwischen den verschiedenen Teilen nicht garantiert ist. Halten Sie die dargestellte Reihenfolge ein, um die Synchronisierung nachzubilden. Die erste dargestellte Platte schließt sich an die fünfte an, um eine unendliche Lösung zu garantieren. Der Effekt der durchgehenden Aderung zwischen den verschiedenen Teilen unterliegt der typischen Toleranz des Produktes aus Stein.



# infinito 2.0

GRAPHICS 160x320



246 INFINITO 2.0\_MARBLE EFFECT

247 INFINITO 2.0\_MARBLE EFFECT

## CALACATTA GOLD

Nel formato 160x320 il "Calacatta Gold" è prodotto in 4 differenti facce per accentuare l'effetto naturale tipico del marmo. In fase di approntamento dell'ordine, la selezione delle facce è random, pertanto la venatura continuativa fra i diversi pezzi non è garantita. Rispettare la successione raffigurata per ricreare la sincronizzazione. La prima lastra raffigurata si aggancia alla quarta per garantire una soluzione infinita. L'effetto vena continua fra i diversi pezzi è soggetta alla tolleranza tipica del prodotto lapideo. | In the 160x320 size, "Calacatta Gold" is available with four different faces, to accentuate the natural look so typical of marble. When preparing the order, the different versions are chosen randomly, which means continuous veining between the different pieces is not guaranteed. Follow the sequence shown to recreate the synchronised effect. To ensure an endless finish, the sequence must be repeated continually, with the first slab placed after the fourth. The continuous veining effect across the various tiles is subject to the typical tolerance of stone products. | Dans le format 160x320 le "Calacatta Gold" est produit en 4 faces différentes pour accentuer l'effet naturel typique du marbre. Au moment de la préparation de la commande, la sélection

des faces est fortuite ; la continuité des veines entre les différentes pièces n'est donc pas garantie. Respecter la succession représentée pour recréer la synchronisation. La première dalle représentée s'accroche à la quatrième pour garantir une solution infinie. L'effet de la veine continue entre les différentes pièces est soumis à la tolérance typique du produit en pierre. | Beim Format 160x320 wird der "Calacatta Gold" in 4 verschiedenen Oberflächen hergestellt, um den natürlichen Effekt hervorzuheben, der für den Marmor typisch ist. Bei der Vorbereitung des Auftrags erfolgt die Auswahl der Oberflächen nach Zufall, weshalb die durchgehende Aderung zwischen den verschiedenen Teilen nicht garantiert ist. Halten Sie die dargestellte Reihenfolge ein, um die Synchronisierung nachzubilden. Die erste dargestellte Platte schließt sich an die vierte an, um eine unendliche Lösung zu garantieren. Der Effekt der durchgehenden Aderung zwischen den verschiedenen Teilen unterliegt der typischen Toleranz des Produktes aus Stein.



# infinito 2.0

REGISTERED DESIGN



248 INFINITO 2.0\_MARBLE EFFECT

## SIZES & SURFACES



**160x320\***  
62,99"x125,98"



**120x278\*\***  
47,24"x109,45"



**60x120**  
23,62"x47,24"

### 6,5 mm

**Glossy**  
Rettificato | Rectified |  
Rectifié | Rektifiziert

- **160x320** . 62,99"x125,98"  
**INF1246**

**120x278** . 47,24"x109,45"  
**INF1351**

**60x120** . 23,62"x47,24"  
**INF1615**

**Honed**  
Rettificato | Rectified |  
Rectifié | Rektifiziert

- **160x320** . 62,99"x125,98"  
**INF1245**

**120x278** . 47,24"x109,45"  
**INF1484**

**Natural**  
Rettificato | Rectified |  
Rectifié | Rektifiziert

**120x278** . 47,24"x109,45"  
**INF1913**

- Disponibile su richiesta | Available on request | Disponible sur demande | Auf Anfrage erhältlich

## CAPRAIA

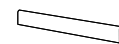

**6,5 mm**  
**8x120** . 3,15"x47,24"  
battiscopa  
**INF1616** glossy



**6,5 mm**  
**33x120x5** . 12,99"x47,24"x1,97"  
gradino lineare LL  
**INF1617** glossy



**6,5 mm**  
**33x120x5** . 12,99"x47,24"x1,97"  
gradino angolare LL  
**INF1618** glossy

**Wall suggested grout**  
103 . Moon White



**Floor suggested grout**  
110 . Manhattan 2000



## CAPRAIA

### LAYING EXAMPLE

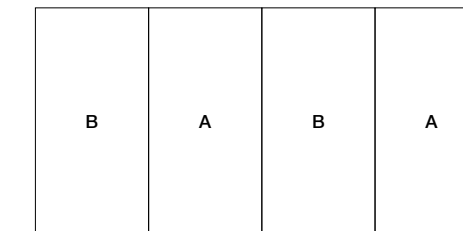
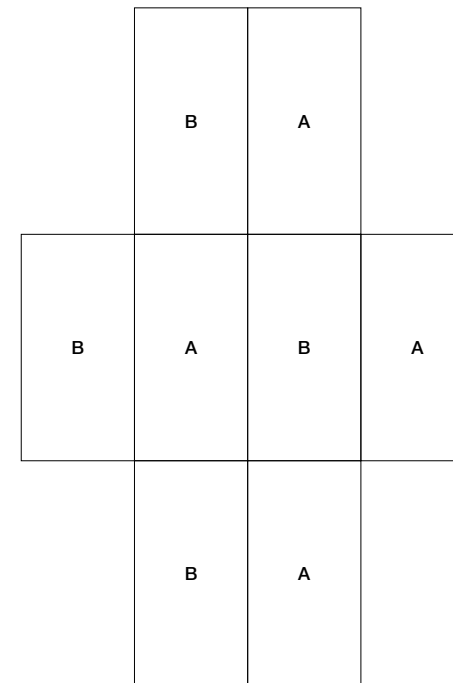

La grafica del Capraia Bookmatch consente di ricreare delle composizioni infinite perchè le venature combaciano sia verticalmente che orizzontalmente. Per ottenere questi effetti speculari, è importante seguire la successione delle lettere come nel disegno proposto. L'effetto Bookmatch tra le diverse lastre è soggetto alla tolleranza tipica del prodotto lapideo. | The aesthetic features of Capraia Bookmatch allow users to recreate endless designs since the veining matches both horizontally and vertically. To ensure this seamless effect, it is important to follow the sequence of letters shown in the design given. The bookmatching effect created by placing different slabs together is subject to the usual joint specifications of stone tiles. | Le graphisme du Capraia Bookmatch permet de recréer des compositions infinies parce que les veines coïncident verticalement et horizontalement. Pour obtenir ces effets spéculaire, il est important de suivre la succession des lettres d'après le dessin proposé. L'effet Bookmatch entre différentes dalles est soumis à la tolérance typique du produit en pierre. | Die Grafik des Capraia Bookmatch ermöglicht die Bildung von unendlich vielen Zusammenstellungen, da die Aderungen sowohl vertikal als auch horizontal aneinander passen. Zur Erzielung dieser spiegelbildlichen Effekte ist es wichtig, die Buchstaben nacheinander auszuführen, wie in der vorgeschlagenen Zeichnung. Der Effekt des Bookmatching zwischen den verschiedenen Platten unterliegt der typischen Toleranz des Produktes aus Stein.

249 INFINITO 2.0\_MARBLE EFFECT



# infinito 2.0

REGISTERED DESIGN

GRAPHICS 120x278



250 INFINITO 2.0\_MARBLE EFFECT

251 INFINITO 2.0\_MARBLE EFFECT

CAPRAIA

Nel formato 120x278 il "Capraia" è prodotto in 5 differenti facce per accentuare l'effetto naturale tipico del marmo. In fase di approntamento dell'ordine, la selezione delle facce è random, pertanto la venatura continuativa fra i diversi pezzi non è garantita. Rispettare la successione raffigurata per ricreare la sincronizzazione. La prima lastra raffigurata si aggancia alla quinta per garantire una soluzione infinita. L'effetto vena continua fra i diversi pezzi è soggetta alla tolleranza tipica del prodotto lapideo. | In the 120x278 size, "Capraia" is available with five different faces, to accentuate the natural look so typical of marble. When preparing the order, the different versions are chosen randomly, which means continuous veining between the different pieces is not guaranteed. Follow the sequence shown to recreate the synchronised effect. To ensure an endless finish, the sequence must be repeated continually, with the first slab placed after the fifth. The continuous veining effect across the various tiles is subject to the typical tolerance of stone products. | Dans le format 120x278 le "Capraia" est produit en 5 faces différentes pour accentuer l'effet naturel typique du marbre. Au moment de la préparation de la commande, la

sélection des faces est fortuite ; la continuité des veines entre les différentes pièces n'est donc pas garantie. Respecter la succession représentée pour recréer la synchronisation. La première dalle représentée s'accroche à la cinquième pour garantir une solution infinie. L'effet de la veine continue entre les différentes pièces est soumis à la tolérance typique du produit en pierre. | Beim Format 120x278 wird der "Capraia" in 5 verschiedenen Oberflächen hergestellt, um den natürlichen Effekt hervorzuheben, der für den Marmor typisch ist. Bei der Vorbereitung des Auftrags erfolgt die Auswahl der Oberflächen nach Zufall, weshalb die durchgehende Aderung zwischen den verschiedenen Teilen nicht garantiert ist. Halten Sie die dargestellte Reihenfolge ein, um die Synchronisierung nachzubilden. Die erste dargestellte Platte schließt sich an die fünfte an, um eine unendliche Lösung zu garantieren. Der Effekt der durchgehenden Aderung zwischen den verschiedenen Teilen unterliegt der typischen Toleranz des Produktes aus Stein.



# infinito 2.0

REGISTERED DESIGN

GRAPHICS 160x320



252 INFINITO 2.0\_MARBLE EFFECT

253 INFINITO 2.0\_MARBLE EFFECT

## CAPRAIA

Nel formato 160x320 il "Capraia" è prodotto in 4 differenti facce per accentuare l'effetto naturale tipico del marmo. In fase di approntamento dell'ordine, la selezione delle facce è random, pertanto la venatura continuativa fra i diversi pezzi non è garantita. Rispettare la successione raffigurata per ricreare la sincronizzazione. La prima lastra raffigurata si aggancia alla quarta per garantire una soluzione infinita. L'effetto vena continua fra i diversi pezzi è soggetta alla tolleranza tipica del prodotto lapideo. | In the 160x320 size, "Capraia" is available with four different faces, to accentuate the natural look so typical of marble. When preparing the order, the different versions are chosen randomly, which means continuous veining between the different pieces is not guaranteed. Follow the sequence shown to recreate the synchronised effect. To ensure an endless finish, the sequence must be repeated continually, with the first slab placed after the fourth. The continuous veining effect across the various tiles is subject to the typical tolerance of stone products. | Dans le format 160x320 le "Capraia" est produit en 4 faces différentes pour accentuer l'effet naturel typique du marbre. Au moment de la préparation de la commande, la sélection des faces est fortuite ; la continuité

des veines entre les différentes pièces n'est donc pas garantie. Respecter la succession représentée pour recréer la synchronisation. La première dalle représentée s'accroche à la quatrième pour garantir une solution infinie. L'effet de la veine continue entre les différentes pièces est soumis à la tolérance typique du produit en pierre. | Beim Format 160x320 wird der "Capraia" in 4 verschiedenen Oberflächen hergestellt, um den natürlichen Effekt hervorzuheben, der für den Marmor typisch ist. Bei der Vorbereitung des Auftrags erfolgt die Auswahl der Oberflächen nach Zufall, weshalb die durchgehende Aderung zwischen den verschiedenen Teilen nicht garantiert ist. Halten Sie die dargestellte Reihenfolge ein, um die Synchronisierung nachzubilden. Die erste dargestellte Platte schließt sich an die vierte an, um eine unendliche Lösung zu garantieren. Der Effekt der durchgehenden Aderung zwischen den verschiedenen Teilen unterliegt der typischen Toleranz des Produktes aus Stein.





# infinito 2.0

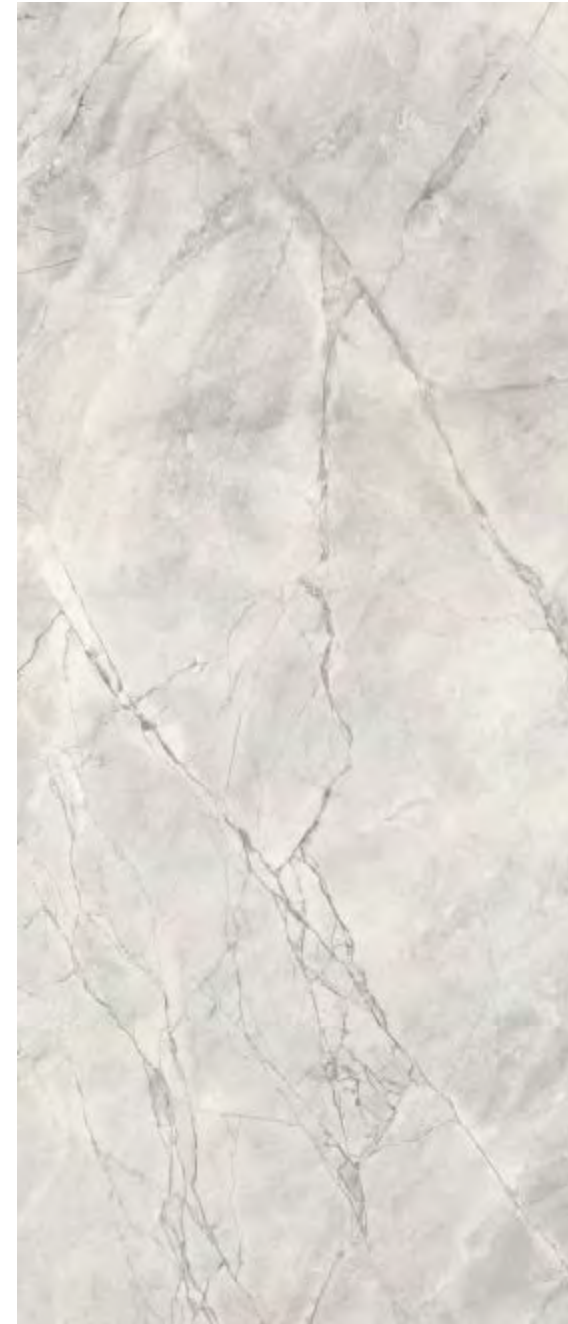

**SUPER WHITE**

**SIZES & SURFACES**

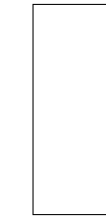

**120x278\*\***  
47,24"x109,45"



**60x120**  
23,62"x47,24"

**6,5 mm**

**Glossy**  
Rettificato | Rectified |  
Rectifié | Rektifiziert

**120x278** . 47,24"x109,45"  
**INF1747**

**60x120** . 23,62"x47,24"  
**INF1752**

**Natural**  
Rettificato | Rectified |  
Rectifié | Rektifiziert

**120x278** . 47,24"x109,45"  
**INF1905**

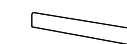

**6,5 mm**  
**8x120** . 3,15"x47,24"  
battiscopa  
**INF1753** glossy

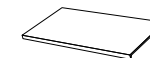

**6,5 mm**  
**33x120x5** . 12,99"x47,24"x1,97"  
gradino lineare LL  
**INF1754** glossy

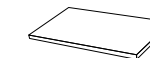

**6,5 mm**  
**33x120x5** . 12,99"x47,24"x1,97"  
gradino angolare LL  
**INF1755** glossy

**Suggested grout**  
110 . Manhattan 2000





# infinito 2.0

GRAPHICS 120x278

256 INFINITO 2.0\_MARBLE EFFECT



1

2

3

4

5

**SUPER WHITE**

257 INFINITO 2.0\_MARBLE EFFECT

Nel formato 120x278 il "Super White" è prodotto in 5 differenti facce per accentuare l'effetto naturale tipico del marmo. In fase di approntamento dell'ordine, la selezione delle facce è random, pertanto la venatura continuativa fra i diversi pezzi non è garantita. Rispettare la successione raffigurata per ricreare la sincronizzazione. La prima lastra raffigurata si aggancia alla quinta per garantire una soluzione infinita. L'effetto vena continua fra i diversi pezzi è soggetto alla tolleranza tipica del prodotto lapideo. | In the 120x278 size, "Super White" is available with five different faces, to accentuate the natural look so typical of marble. When preparing the order, the different versions are chosen randomly, which means continuous veining between the different pieces is not guaranteed. Follow the sequence shown to recreate the synchronised effect. To ensure an endless finish, the sequence must be repeated continually, with the first slab placed after the fifth. The continuous veining effect across the various tiles is subject to the typical tolerance of stone products. | Dans le format 120x278 le "Super White" est produit en 5 faces différentes pour accentuer l'effet naturel typique du marbre. Au moment de la préparation de la commande,

la sélection des faces est fortuite ; la continuité des veines entre les différentes pièces n'est donc pas garantie. Respecter la succession représentée pour recréer la synchronisation. La première dalle représentée s'accroche à la cinquième pour garantir une solution infinie. L'effet de la veine continue entre les différentes pièces est soumis à la tolérance typique du produit en pierre. | Beim Format 120x278 wird der "Super White" in 5 verschiedenen Oberflächen hergestellt, um den natürlichen Effekt hervorzuheben, der für den Marmor typisch ist. Bei der Vorbereitung des Auftrags erfolgt die Auswahl der Oberflächen nach Zufall, weshalb die durchgehende Aderung zwischen den verschiedenen Teilen nicht garantiert ist. Halten Sie die dargestellte Reihenfolge ein, um die Synchronisierung nachzubilden. Die erste dargestellte Platte schließt sich an die fünfte an, um eine unendliche Lösung zu garantieren. Der Effekt der durchgehenden Aderung zwischen den verschiedenen Teilen unterliegt der typischen Toleranz des Produktes aus Stein.





# infinito 2.0

REGISTERED DESIGN



ONICE WHITE

SIZES & SURFACES



**160x320\***  
62,99"x125,98"

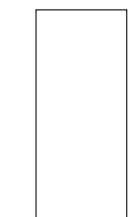

**120x278\*\***  
47,24"x109,45"



**60x120**  
23,62"x47,24"

**6,5 mm**

Glossy  
Rettificato | Rectified |  
Rectifié | Rektifiziert

• **160x320** . 62,99"x125,98"  
**INF1082**

**120x278** . 47,24"x109,45"  
**INF1135**

**60x120** . 23,62"x47,24"  
**INF1087**

• Disponibile su richiesta | Available on request | Disponible sur demande |  
Auf Anfrage erhältlich

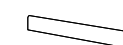

**6,5 mm**  
**8x120** . 3,15"x47,24"  
battiscopa  
**INF1088** glossy

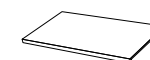

**6,5 mm**  
**33x120x5** . 12,99"x47,24"x1,97"  
gradino lineare LL  
**INF1089** glossy

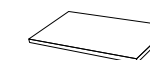

**6,5 mm**  
**33x120x5** . 12,99"x47,24"x1,97"  
gradino angolare LL  
**INF1090** glossy

**Suggested grout**  
137 . Caribbean





# infinito 2.0

REGISTERED DESIGN

GRAPHICS 120x278

260 INFINITO 2.0\_MARBLE EFFECT



1



2



3



4



5



6

261 INFINITO 2.0\_MARBLE EFFECT

ONICE WHITE

120x278 Prodotto con 6 diverse grafiche confezionate in modo casuale | Produced with a variety of a range of 6 different graphic designs which are randomly combined and then packed | Produit avec 6 différents graphismes conditionnés de façon fortuite | Mit 6 unterschiedlichen Graphiken hergestellt und mit einer zufälliger Auswahl verpackt



# infinito 2.0

GRAPHICS 160x320

REGISTERED DESIGN

262 INFINITO 2.0\_MARBLE EFFECT



1

ONICE WHITE



2



3

263 INFINITO 2.0\_MARBLE EFFECT

160x320\_Prodotto con 3 diverse grafiche confezionate in modo casuale | Produced with a variety of a range of 3 different graphic designs which are randomly combined and then packed | Produit avec 3 différents graphismes conditionnés de façon fortuite | Mit 3 unterschiedlichen Graphiken hergestellt und mit einer zufälliger Auswahl verpackt





# infinito 2.0



PATAGONIA

SIZES & SURFACES



120x278\*\*  
47,24"x109,45"

**6,5 mm**

**Glossy**  
Rettificato | Rectified |  
Rectifié | Rektifiziert

**120x278 . 47,24"x109,45"**  
**INF1629**

**Suggested grout**  
130 . Jasmine





# infinito 2.0

GRAPHICS 120x278

266 INFINITO 2.0\_MARBLE EFFECT



1



2



3



4



5

PATAGONIA

267 INFINITO 2.0\_MARBLE EFFECT

120x278 Prodotto con 5 diverse grafiche confezionate in modo casuale | Produced with a variety of a range of 5 different graphic designs which are randomly combined and then packed | Produit avec 5 différents graphismes conditionnés de façon fortuite | Mit 5 unterschiedlichen Graphiken hergestellt und mit einer zufälliger Auswahl verpackt





# infinito 2.0



TAJ MAHAL

SIZES & SURFACES



120x278\*\*  
47,24"x109,45"

**6,5 mm**

**Glossy**  
Rettificato | Rectified |  
Rectifié | Rektifiziert

**120x278** . 47,24"x109,45"  
**INF1888**

**Suggested grout**  
137 . Caribbean





# infinito 2.0

GRAPHICS 120x278

270 INFINITO 2.0\_MARBLE EFFECT



1



2



3

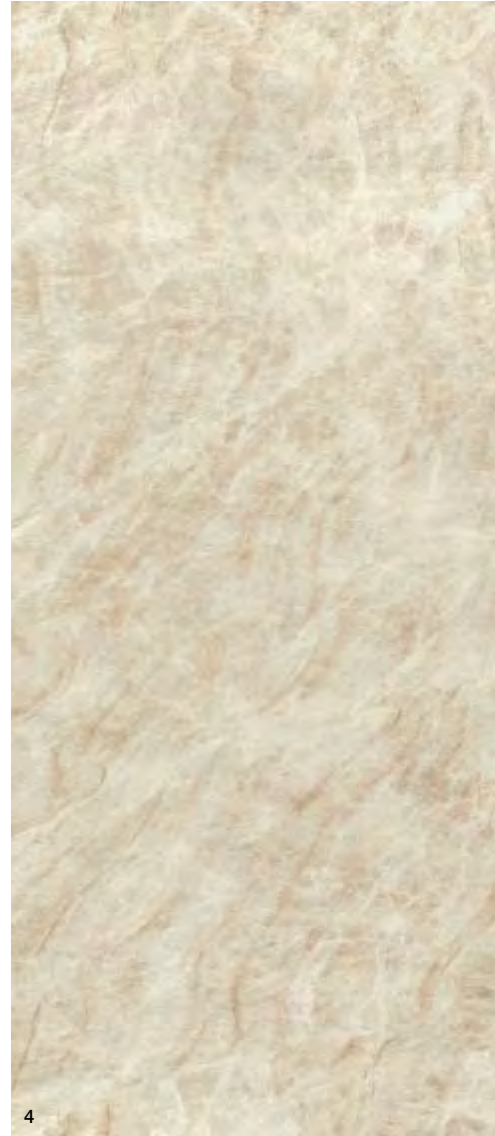

4

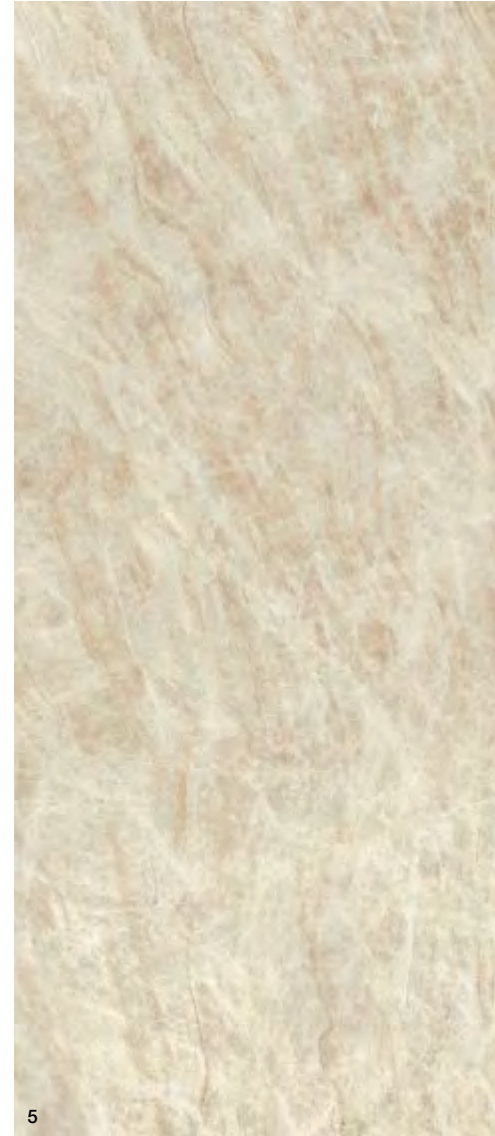

5



6

271 INFINITO 2.0\_MARBLE EFFECT

TAJ MAHAL

120x278 Prodotto con 6 diverse grafiche confezionate in modo casuale | Produced with a variety of a range of 6 different graphic designs which are randomly combined and then packed | Produit avec 6 différents graphismes conditionnés de façon fortuite | Mit 6 unterschiedlichen Graphiken hergestellt und mit einer zufälliger Auswahl verpackt





# infinito 2.0



CALACATTA VIOLA

SIZES & SURFACES



120x278\*\*  
47,24"x109,45"

**6,5 mm**

**Glossy**  
Rettificato | Rectified |  
Rectifié | Rektifiziert

**120x278 . 47,24"x109,45"**  
**INF2161**

Wall suggested grout  
103 . Moon White



Floor suggested grout  
110 . Manhattan 2000





# infinito 2.0

GRAPHICS 120x278



CALACATTA VIOLA

274 INFINITO 2.0\_MARBLE EFFECT

275 INFINITO 2.0\_MARBLE EFFECT

Nel formato 120x278 il "Calacatta Viola" è prodotto in 5 differenti facce per accentuare l'effetto naturale tipico del marmo. In fase di approntamento dell'ordine, la selezione delle facce è random, pertanto la venatura continuativa fra i diversi pezzi non è garantita. Rispettare la successione raffigurata per ricreare la sincronizzazione. La prima lastra raffigurata si aggancia alla quinta per garantire una soluzione infinita. L'effetto vena continua fra i diversi pezzi è soggetta alla tolleranza tipica del prodotto lapideo. | In the 120x278 size, "Calacatta Viola" is available with five different faces, to accentuate the natural look so typical of marble. When preparing the order, the different versions are chosen randomly, which means continuous veining between the different pieces is not guaranteed. Follow the sequence shown to recreate the synchronised effect. To ensure an endless finish, the sequence must be repeated continually, with the first slab placed after the fifth. The continuous veining effect across the various tiles is subject to the typical tolerance of stone products. | Dans le format 120x278 le "Calacatta Viola" est produit en 5 faces différentes pour accentuer l'effet naturel typique du marbre. Au moment de la préparation de

la commande, la sélection des faces est fortuite ; la continuité des veines entre les différentes pièces n'est donc pas garantie. Respecter la succession représentée pour recréer la synchronisation. La première dalle représentée s'accroche à la cinquième pour garantir une solution infinie. L'effet de la veine continue entre les différentes pièces est soumis à la tolérance typique du produit en pierre. | Beim Format 120x278 wird der "Calacatta Viola" in 5 verschiedenen Oberflächen hergestellt, um den natürlichen Effekt hervorzuheben, der für den Marmor typisch ist. Bei der Vorbereitung des Auftrags erfolgt die Auswahl der Oberflächen nach Zufall, weshalb die durchgehende Aderung zwischen den verschiedenen Teilen nicht garantiert ist. Halten Sie die dargestellte Reihenfolge ein, um die Synchronisierung nachzubilden. Die erste dargestellte Platte schließt sich an die fünfte an, um eine unendliche Lösung zu garantieren. Der Effekt der durchgehenden Aderung zwischen den verschiedenen Teilen unterliegt der typischen Toleranz des Produktes aus Stein.



# infinito 2.0



## SIZES & SURFACES



**160x320\***  
62,99"x125,98"



**120x278\*\***  
47,24"x109,45"

**6,5 mm**

**Glossy**  
Rettificato | Rectified |  
Rectifié | Rektifiziert

**120x278 . 47,24"x109,45"**  
**INF1878**

**Suggested grout**  
130 . Jasmine



**CALACATTA MACCHIA VECCHIA**

## LAYING EXAMPLE

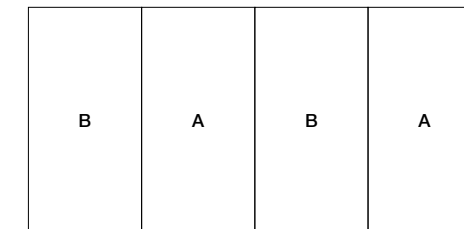
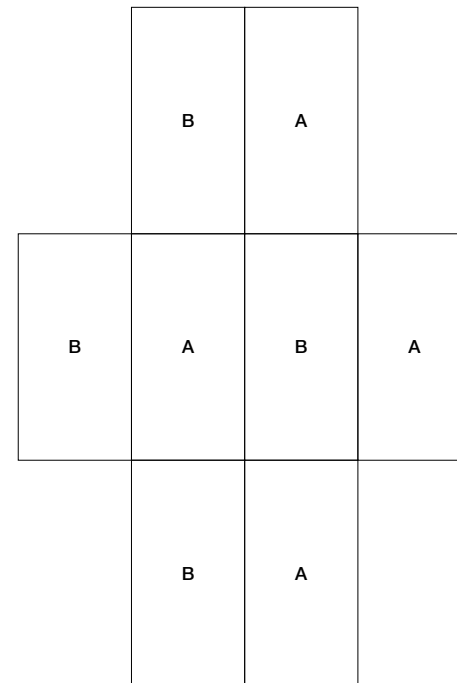

**BOOKMATCH "A" 160x320**

**6,5 mm**

**Natural**  
Rettificato | Rectified |  
Rectifié | Rektifiziert

**160x320 . 62,99"x125,98"**  
**INF2096**

**BOOKMATCH "B" 160x320**

**6,5 mm**

**Natural**  
Rettificato | Rectified |  
Rectifié | Rektifiziert

**160x320 . 62,99"x125,98"**  
**INF2097**

La grafica del Calacatta Macchia Vecchia Bookmatch consente di ricreare delle composizioni infinite perché le venature combaciano sia verticalmente che orizzontalmente. Per ottenere questi effetti speculari, è importante seguire la successione delle lettere come nel disegno proposto. L'effetto Bookmatch tra le diverse lastre è soggetto alla tolleranza tipica del prodotto lapideo. | The aesthetic features of Calacatta Macchia Vecchia Bookmatch allow users to recreate endless designs since the veining matches both horizontally and vertically. To ensure this seamless effect, it is important to follow the sequence of letters shown in the design given. The bookmatching effect created by placing different slabs together is subject to the usual joint specifications of stone tiles. | Le graphisme du Calacatta Macchia Vecchia Bookmatch permet de recréer des compositions infinies parce que les veines coincident verticalement et horizontalement. Pour obtenir ces effets spéculaire, il est important de suivre la succession des lettres d'après le dessin proposé. L'effet Bookmatch entre différentes dalles est soumis à la tolérance typique du produit en pierre. | Die Grafik des Calacatta Macchia Vecchia Bookmatch ermöglicht die Bildung von unendlich vielen Zusammenstellungen, da die Aderungen sowohl vertikal als auch horizontal aneinander passen. Zur Erzielung dieser spiegelbildlichen Effekte ist es wichtig, die Buchstaben nacheinander auszuführen, wie in der vorgeschlagenen Zeichnung. Der Effekt des Bookmatching zwischen den verschiedenen Platten unterliegt der typischen Toleranz des Produktes aus Stein.



# infinito 2.0

GRAPHICS 120x278



CALACATTA MACCHIA VECCHIA

278 INFINITO 2.0\_MARBLE EFFECT

279 INFINITO 2.0\_MARBLE EFFECT

Nel formato 120x278 il "Calacatta Macchia Vecchia" è prodotto in 5 differenti facce per accentuare l'effetto naturale tipico del marmo. In fase di approntamento dell'ordine, la selezione delle facce è random, pertanto la venatura continuativa fra i diversi pezzi non è garantita. Rispettare la successione raffigurata per ricreare la sincronizzazione. La prima lastra raffigurata si aggancia alla quinta per garantire una soluzione infinita. L'effetto vena continua fra i diversi pezzi è soggetta alla tolleranza tipica del prodotto lapideo. | In the 120x278 size, "Calacatta Macchia Vecchia" is available with five different faces, to accentuate the natural look so typical of marble. When preparing the order, the different versions are chosen randomly, which means continuous veining between the different pieces is not guaranteed. Follow the sequence shown to recreate the synchronised effect. To ensure an endless finish, the sequence must be repeated continually, with the first slab placed after the fifth. The continuous veining effect across the various tiles is subject to the typical tolerance of stone products. | Dans le format 120x278 le "Calacatta Macchia Vecchia" est produit en 5 faces différentes pour accentuer l'effet naturel typique du marbre. Au moment

de la préparation de la commande, la sélection des faces est fortuite ; la continuité des veines entre les différentes pièces n'est donc pas garantie. Respecter la succession représentée pour recréer la synchronisation. La première dalle représentée s'accroche à la cinquième pour garantir une solution infinie. L'effet de la veine continue entre les différentes pièces est soumis à la tolérance typique du produit en pierre. | Beim Format 120x278 wird der "Calacatta Macchia Vecchia" in 5 verschiedenen Oberflächen hergestellt, um den natürlichen Effekt hervorzuheben, der für den Marmor typisch ist. Bei der Vorbereitung des Auftrags erfolgt die Auswahl der Oberflächen nach Zufall, weshalb die durchgehende Aderung zwischen den verschiedenen Teilen nicht garantiert ist. Halten Sie die dargestellte Reihenfolge ein, um die Synchronisierung nachzubilden. Die erste dargestellte Platte schließt sich an die fünfte an, um eine unendliche Lösung zu garantieren. Der Effekt der durchgehenden Aderung zwischen den verschiedenen Teilen unterliegt der typischen Toleranz des Produktes aus Stein.





# infinito 2.0



GOLD RIVER

### SIZES & SURFACES

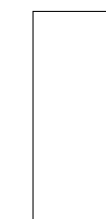

120x278\*\*  
47,24"x109,45"

6,5 mm

Glossy  
Rettificato | Rectified |  
Rectifié | Rektifiziert

120x278 . 47,24"x109,45"  
INF1882

Suggested grout  
137 . Caribbean





# infinito 2.0

GRAPHICS 120x278

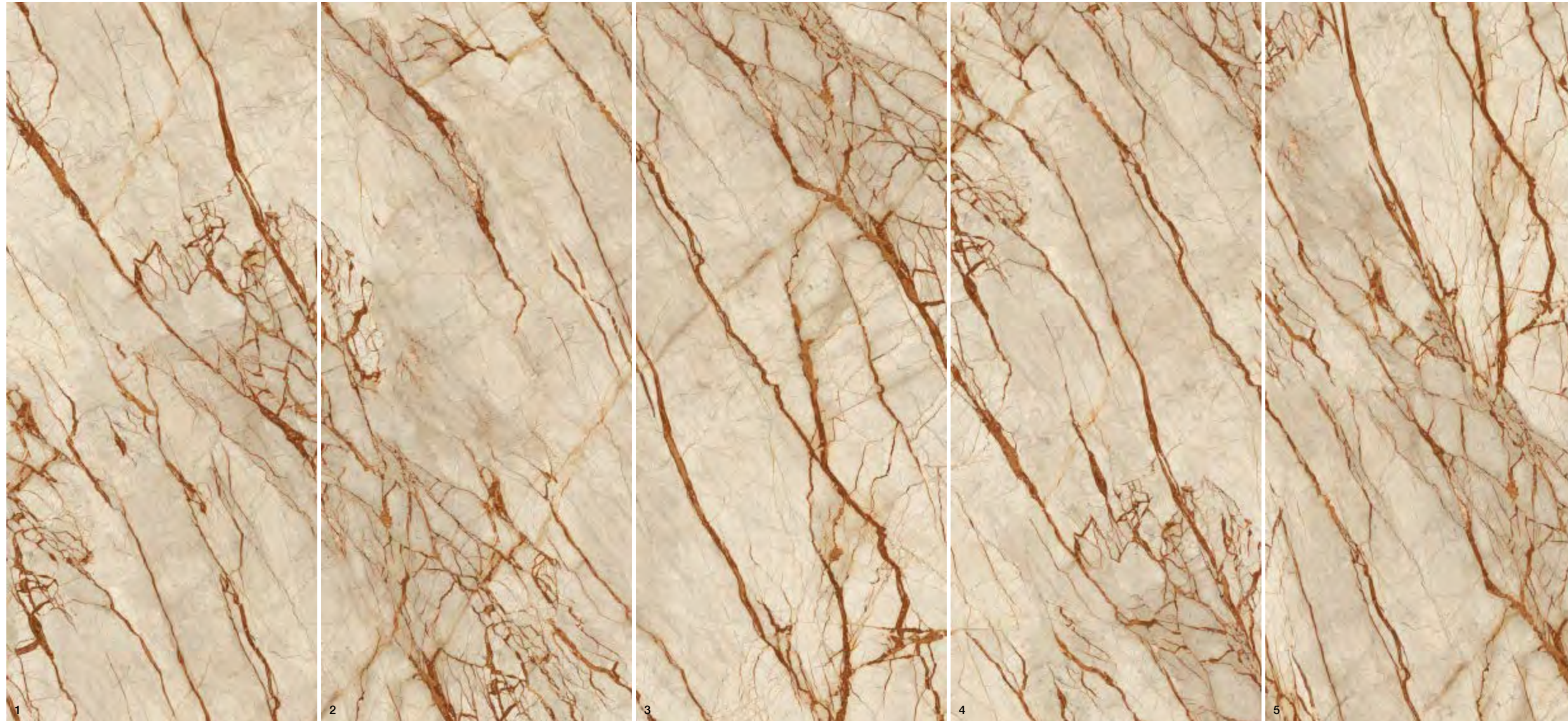

GOLD RIVER

282 INFINITO 2.0\_MARBLE EFFECT

283 INFINITO 2.0\_MARBLE EFFECT

Nel formato 120x278 il "Gold River" è prodotto in 5 differenti facce per accentuare l'effetto naturale tipico del marmo. In fase di approntamento dell'ordine, la selezione delle facce è random, pertanto la venatura continuativa fra i diversi pezzi non è garantita. Rispettare la successione raffigurata per ricreare la sincronizzazione. La prima lastra raffigurata si aggancia alla quinta per garantire una soluzione infinita. L'effetto vena continua fra i diversi pezzi è soggetta alla tolleranza tipica del prodotto lapideo. | In the 120x278 size, "Gold River" is available with five different faces, to accentuate the natural look so typical of marble. When preparing the order, the different versions are chosen randomly, which means continuous veining between the different pieces is not guaranteed. Follow the sequence shown to recreate the synchronised effect. To ensure an endless finish, the sequence must be repeated continually, with the first slab placed after the fifth. The continuous veining effect across the various tiles is subject to the typical tolerance of stone products. | Dans le format 120x278 le "Gold River" est produit en 5 faces différentes pour accentuer l'effet naturel typique du marbre. Au moment de la préparation de la commande,

la sélection des faces est fortuite ; la continuité des veines entre les différentes pièces n'est donc pas garantie. Respecter la succession représentée pour recréer la synchronisation. La première dalle représentée s'accroche à la cinquième pour garantir une solution infinie. L'effet de la veine continue entre les différentes pièces est soumis à la tolérance typique du produit en pierre. | Beim Format 120x278 wird der "Gold river" in 5 verschiedenen Oberflächen hergestellt, um den natürlichen Effekt hervorzuheben, der für den Marmor typisch ist. Bei der Vorbereitung des Auftrags erfolgt die Auswahl der Oberflächen nach Zufall, weshalb die durchgehende Aderung zwischen den verschiedenen Teilen nicht garantiert ist. Halten Sie die dargestellte Reihenfolge ein, um die Synchronisierung nachzubilden. Die erste dargestellte Platte schließt sich an die fünfte an, um eine unendliche Lösung zu garantieren. Der Effekt der durchgehenden Aderung zwischen den verschiedenen Teilen unterliegt der typischen Toleranz des Produktes aus Stein.





# infinito 2.0



BRECCIA VAN GOGH

SIZES & SURFACES



120x278\*\*  
47,24"x109,45"

**6,5 mm**

**Glossy**  
Rettificato | Rectified |  
Rectifié | Rektifiziert

**120x278 . 47,24"x109,45"**  
**INF2276**

**Suggested grout**  
113 . Cement Grey





# infinito 2.0

GRAPHICS 120x278



BRECCIA VAN GOGH

Nel formato 120x278 il "Breccia Van Gogh" è prodotto in 5 differenti facce per accentuare l'effetto naturale tipico del marmo. In fase di approntamento dell'ordine, la selezione delle facce è random, pertanto la venatura continuativa fra i diversi pezzi non è garantita. Rispettare la successione raffigurata per ricreare la sincronizzazione. La prima lastra raffigurata si aggancia alla quinta per garantire una soluzione infinita. L'effetto vena continua fra i diversi pezzi è soggetto alla tolleranza tipica del prodotto lapideo. | In the 120x278 size, "Breccia Van Gogh" is available with five different faces, to accentuate the natural look so typical of marble. When preparing the order, the different versions are chosen randomly, which means continuous veining between the different pieces is not guaranteed. Follow the sequence shown to recreate the synchronised effect. To ensure an endless finish, the sequence must be repeated continually, with the first slab placed after the fifth. The continuous veining effect across the various tiles is subject to the typical tolerance of stone products. | Dans le format 120x278 le "Breccia Van Gogh" est produit en 5 faces différentes pour accentuer l'effet naturel typique du marbre. Au moment de la préparation

de la commande, la sélection des faces est fortuite ; la continuité des veines entre les différentes pièces n'est donc pas garantie. Respecter la succession représentée pour recréer la synchronisation. La première dalle représentée s'accroche à la cinquième pour garantir une solution infinie. L'effet de la veine continue entre les différentes pièces est soumis à la tolérance typique du produit en pierre. | Beim Format 120x278 wird der "Breccia Van Gogh" in 5 verschiedenen Oberflächen hergestellt, um den natürlichen Effekt hervorzuheben, der für den Marmor typisch ist. Bei der Vorbereitung des Auftrags erfolgt die Auswahl der Oberflächen nach Zufall, weshalb die durchgehende Aderung zwischen den verschiedenen Teilen nicht garantiert ist. Halten Sie die dargestellte Reihenfolge ein, um die Synchronisierung nachzubilden. Die erste dargestellte Platte schließt sich an die fünfte an, um eine unendliche Lösung zu garantieren. Der Effekt der durchgehenden Aderung zwischen den verschiedenen Teilen unterliegt der typischen Toleranz des Produktes aus Stein.





# infinito 2.0

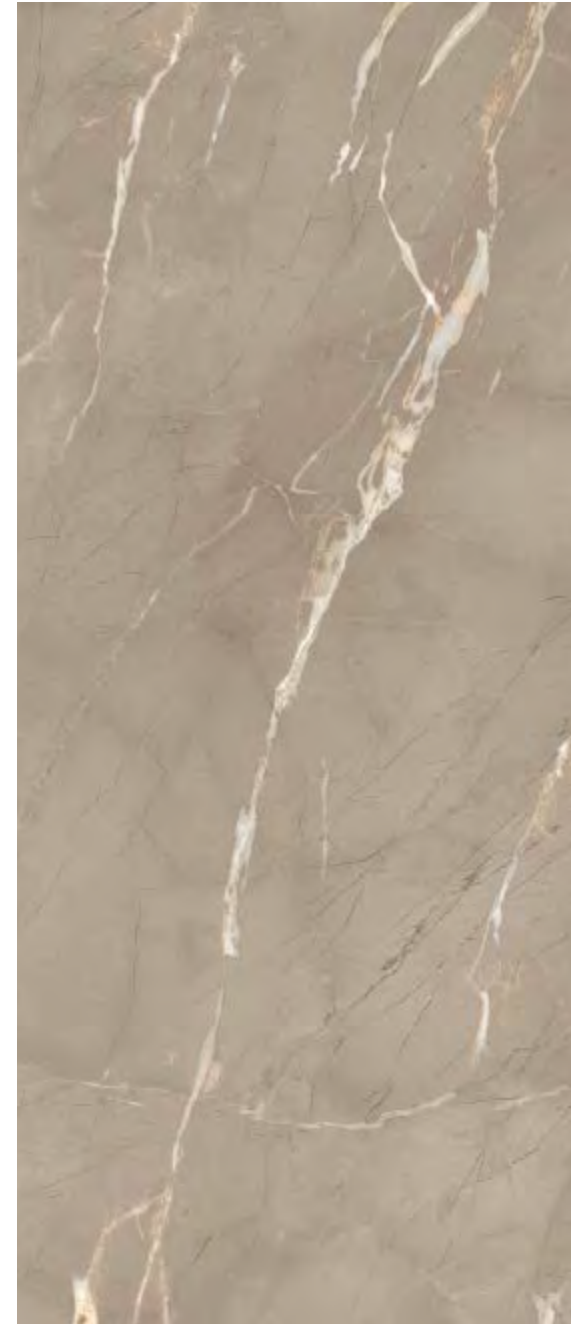

ROYAL CREAMY

SIZES & SURFACES



120x278\*\*  
47,24"x109,45"

6,5 mm

Natural  
Rettificato | Rectified |  
Rectifié | Rektifiziert

120x278 . 47,24"x109,45"  
INF1874

Suggested grout  
187 . Linen





# infinito 2.0

GRAPHICS 120x278



ROYAL CREAMY

290 INFINITO 2.0\_MARBLE EFFECT

291 INFINITO 2.0\_MARBLE EFFECT

Nel formato 120x278 il "Royal Creamy" è prodotto in 5 differenti facce per accentuare l'effetto naturale tipico del marmo. In fase di approntamento dell'ordine, la selezione delle facce è random, pertanto la venatura continuativa fra i diversi pezzi non è garantita. Rispettare la successione raffigurata per ricreare la sincronizzazione. La prima lastra raffigurata si aggancia alla quinta per garantire una soluzione infinita. L'effetto vena continua fra i diversi pezzi è soggetta alla tolleranza tipica del prodotto lapideo. | In the 120x278 size, "Royal Creamy" is available with five different faces, to accentuate the natural look so typical of marble. When preparing the order, the different versions are chosen randomly, which means continuous veining between the different pieces is not guaranteed. Follow the sequence shown to recreate the synchronised effect. To ensure an endless finish, the sequence must be repeated continually, with the first slab placed after the fifth. The continuous veining effect across the various tiles is subject to the typical tolerance of stone products. | Dans le format 120x278 le "Royal Creamy" est produit en 5 faces différentes pour accentuer l'effet naturel typique du marbre. Au moment de la préparation de la commande,

la sélection des faces est fortuite ; la continuité des veines entre les différentes pièces n'est donc pas garantie. Respecter la succession représentée pour recréer la synchronisation. La première dalle représentée s'accroche à la cinquième pour garantir une solution infinie. L'effet de la veine continue entre les différentes pièces est soumis à la tolérance typique du produit en pierre. | Beim Format 120x278 wird der "Royal Creamy" in 5 verschiedenen Oberflächen hergestellt, um den natürlichen Effekt hervorzuheben, der für den Marmor typisch ist. Bei der Vorbereitung des Auftrags erfolgt die Auswahl der Oberflächen nach Zufall, weshalb die durchgehende Aderung zwischen den verschiedenen Teilen nicht garantiert ist. Halten Sie die dargestellte Reihenfolge ein, um die Synchronisierung nachzubilden. Die erste dargestellte Platte schließt sich an die fünfte an, um eine unendliche Lösung zu garantieren. Der Effekt der durchgehenden Aderung zwischen den verschiedenen Teilen unterliegt der typischen Toleranz des Produktes aus Stein.



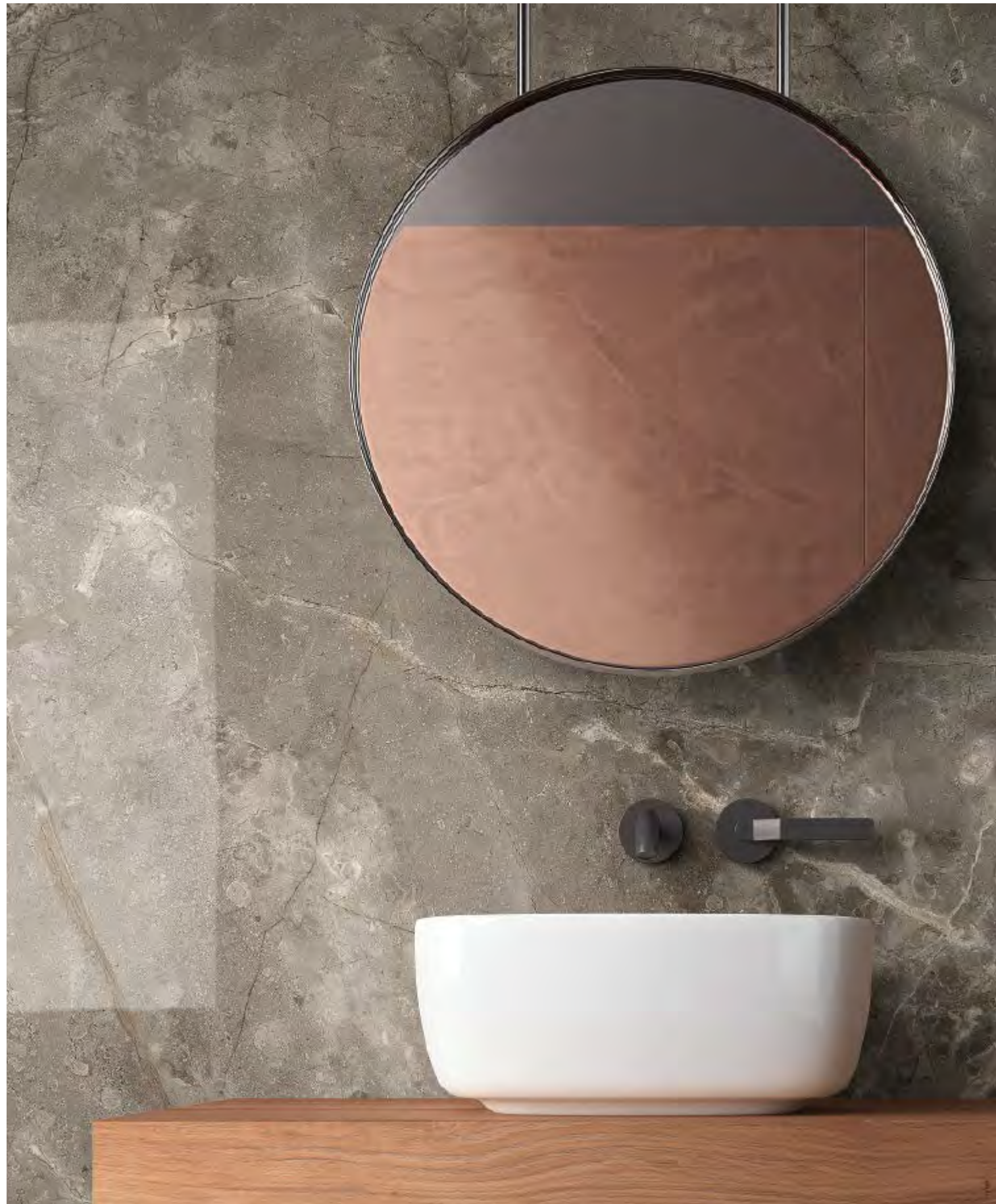

# infinito 2.0



SIZES & SURFACES

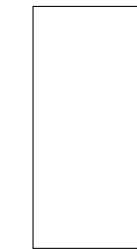

**160x320\***  
62,99"x125,98"

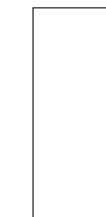

**120x278\*\***  
47,24"x109,45"



**60x120**  
23,62"x47,24"

**6,5 mm**

**Glossy**  
Rettificato | Rectified |  
Rectifié | Rektifiziert

- **160x320** . 62,99"x125,98"  
**INF552**

**120x278** . 47,24"x109,45"  
**INF1150**

**60x120** . 23,62"x47,24"  
**INF827**

**Honed**  
Rettificato | Rectified |  
Rectifié | Rektifiziert

- **160x320** . 62,99"x125,98"  
**INF551**

**120x278** . 47,24"x109,45"  
**INF1149**

**Natural**  
Rettificato | Rectified |  
Rectifié | Rektifiziert

**120x278** . 47,24"x109,45"  
**INF1921**

- Disponibile su richiesta | Available on request | Disponible sur demande | Auf Anfrage erhältlich

**FIOR DI BOSCO**

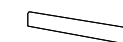

**6,5 mm**  
**8x120** . 3,15"x47,24"  
battiscopa  
**INF601** glossy



**6,5 mm**  
**33x120x5** . 12,99"x47,24"x1,97"  
gradino lineare LL  
**INF604** glossy

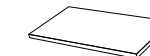

**6,5 mm**  
**33x120x5** . 12,99"x47,24"x1,97"  
gradino angolare LL  
**INF607** glossy

**Suggested grout**  
112 . Medium Grey





# infinito 2.0

GRAPHICS 120x278

294 INFINITO 2.0\_MARBLE EFFECT



FIOR DI BOSCO

295 INFINITO 2.0\_MARBLE EFFECT

Nel formato 120x278 il "Fior di Bosco" è prodotto in 5 differenti facce per accentuare l'effetto naturale tipico del marmo. In fase di approntamento dell'ordine, la selezione delle facce è random, pertanto la venatura continuativa fra i diversi pezzi non è garantita. Rispettare la successione raffigurata per ricreare la sincronizzazione. La prima lastra raffigurata si aggancia alla quinta per garantire una soluzione infinita. L'effetto vena continua fra i diversi pezzi è soggetta alla tolleranza tipica del prodotto lapideo. | In the 120x278 size, "Fior di Bosco" is available with five different faces, to accentuate the natural look so typical of marble. When preparing the order, the different versions are chosen randomly, which means continuous veining between the different pieces is not guaranteed. Follow the sequence shown to recreate the synchronised effect. To ensure an endless finish, the sequence must be repeated continually, with the first slab placed after the fifth. The continuous veining effect across the various tiles is subject to the typical tolerance of stone products. | Dans le format 120x278 le "Fior di Bosco" est produit en 5 faces différentes pour accentuer l'effet naturel typique du marbre. Au moment de la préparation de la commande,

la sélection des faces est fortuite ; la continuité des veines entre les différentes pièces n'est donc pas garantie. Respecter la succession représentée pour recréer la synchronisation. La première dalle représentée s'accroche à la cinquième pour garantir une solution infinie. L'effet de la veine continue entre les différentes pièces est soumis à la tolérance typique du produit en pierre. | Beim Format 120x278 wird der "Fior di Bosco" in 5 verschiedenen Oberflächen hergestellt, um den natürlichen Effekt hervorzuheben, der für den Marmor typisch ist. Bei der Vorbereitung des Auftrags erfolgt die Auswahl der Oberflächen nach Zufall, weshalb die durchgehende Aderung zwischen den verschiedenen Teilen nicht garantiert ist. Halten Sie die dargestellte Reihenfolge ein, um die Synchronisierung nachzubilden. Die erste dargestellte Platte schließt sich an die fünfte an, um eine unendliche Lösung zu garantieren. Der Effekt der durchgehenden Aderung zwischen den verschiedenen Teilen unterliegt der typischen Toleranz des Produktes aus Stein.



# infinito 2.0

GRAPHICS 160x320

296 INFINITO 2.0\_MARBLE EFFECT



FIOR DI BOSCO

Nel formato 160x320 il "Fior di Bosco" è prodotto in 4 differenti facce per accentuare l'effetto naturale tipico del marmo. In fase di approntamento dell'ordine, la selezione delle facce è random, pertanto la venatura continuativa fra i diversi pezzi non è garantita. Rispettare la successione raffigurata per ricreare la sincronizzazione. La prima lastra raffigurata si aggancia alla quarta per garantire una soluzione infinita. L'effetto vena continua fra i diversi pezzi è soggetta alla tolleranza tipica del prodotto lapideo. | In the 160x320 size, "Fior di Bosco" is available with four different faces, to accentuate the natural look so typical of marble. When preparing the order, the different versions are chosen randomly, which means continuous veining between the different pieces is not guaranteed. Follow the sequence shown to recreate the synchronised effect. To ensure an endless finish, the sequence must be repeated continually, with the first slab placed after the fourth. The continuous veining effect across the various tiles is subject to the typical tolerance of stone products. | Dans le format 160x320 le "Fior di Bosco" est produit en 4 faces différentes pour accentuer l'effet naturel typique du marbre. Au moment de la préparation de la commande, la sélection

des faces est fortuite ; la continuité des veines entre les différentes pièces n'est donc pas garantie. Respecter la succession représentée pour recréer la synchronisation. La première dalle représentée s'accroche à la quatrième pour garantir une solution infinie. L'effet de la veine continue entre les différentes pièces est soumis à la tolérance typique du produit en pierre. | Beim Format 160x320 wird der "Fior di Bosco" in 4 verschiedenen Oberflächen hergestellt, um den natürlichen Effekt hervorzuheben, der für den Marmor typisch ist. Bei der Vorbereitung des Auftrags erfolgt die Auswahl der Oberflächen nach Zufall, weshalb die durchgehende Aderung zwischen den verschiedenen Teilen nicht garantiert ist. Halten Sie die dargestellte Reihenfolge ein, um die Synchronisierung nachzubilden. Die erste dargestellte Platte schließt sich an die vierte an, um eine unendliche Lösung zu garantieren. Der Effekt der durchgehenden Aderung zwischen den verschiedenen Teilen unterliegt der typischen Toleranz des Produktes aus Stein.

297 INFINITO 2.0\_MARBLE EFFECT





# infinito 2.0



AMAZONITE

## SIZES & SURFACES



**120x278\*\***  
47,24"x109,45"



**60x120**  
23,62"x47,24"

**6,5 mm**

**Glossy**  
Rettificato | Rectified |  
Rectifié | Rektifiziert

**120x278** . 47,24"x109,45"  
**INF1655**

**60x120** . 23,62"x47,24"  
**INF1952**

**Suggested grout**  
115 . River Grey





# infinito 2.0

GRAPHICS 120x278

300 INFINITO 2.0\_MARBLE EFFECT

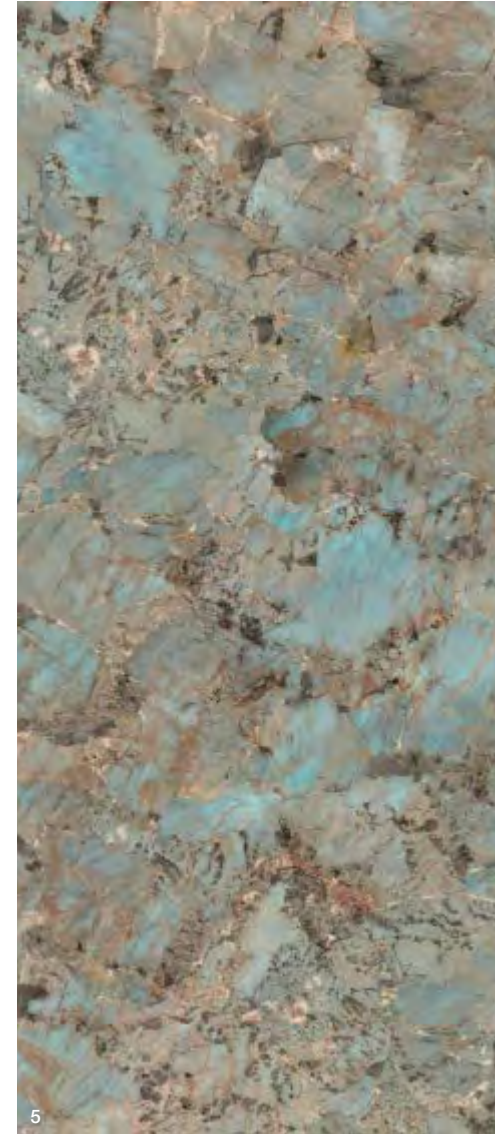
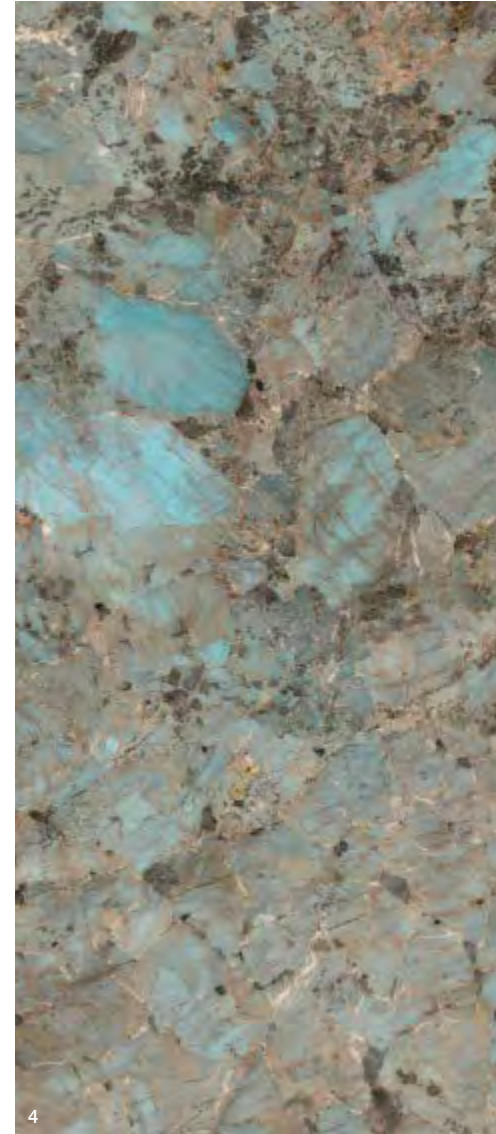
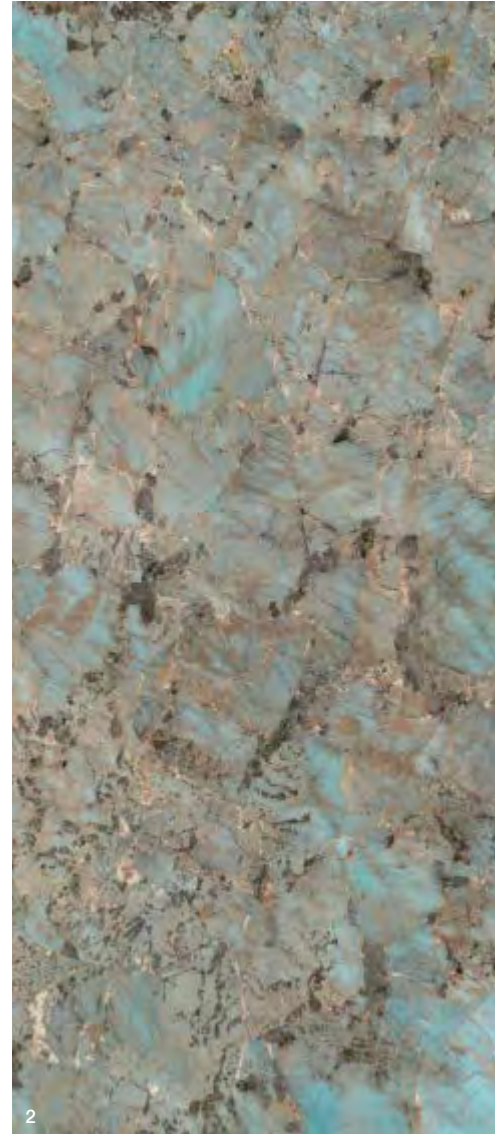

AMAZZONITE

301 INFINITO 2.0\_MARBLE EFFECT

120x278 Prodotto con 5 diverse grafiche confezionate in modo casuale | Produced with a variety of a range of 5 different graphic designs which are randomly combined and then packed | Produit avec 5 différents graphismes conditionnés de façon fortuite | Mit 5 unterschiedlichen Graphiken hergestellt und mit einer zufälliger Auswahl verpackt





# infinito 2.0

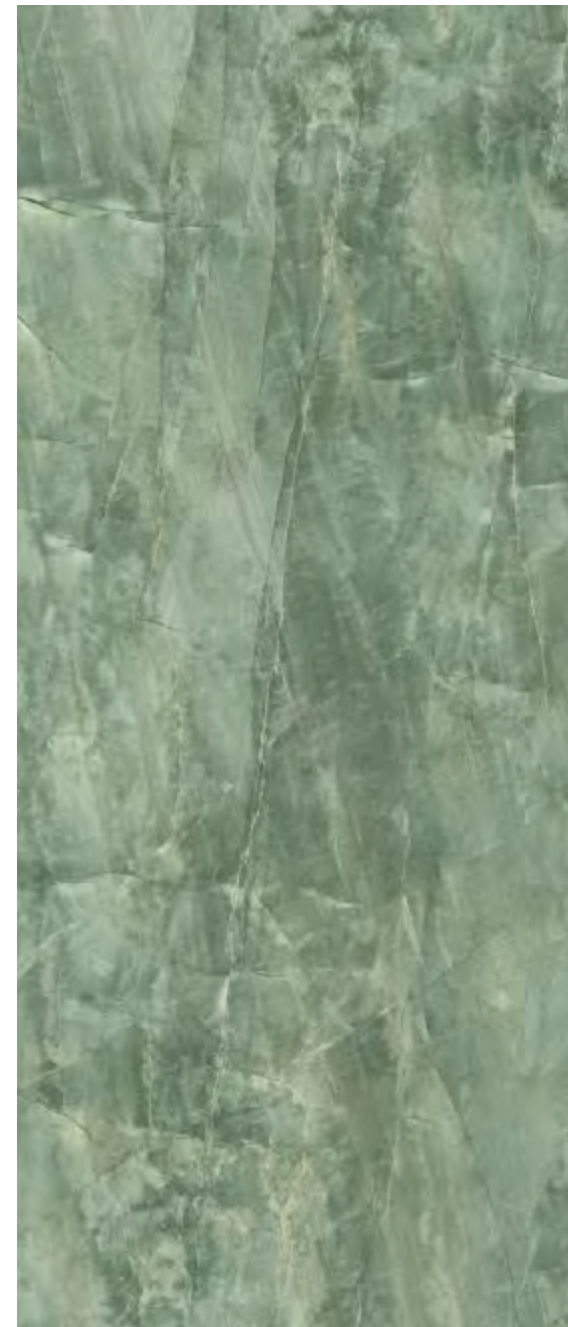

EMERALD GREEN

## SIZES & SURFACES



120x278\*\*  
47,24"x109,45"

**6,5 mm**

**Glossy**  
Rettificato | Rectified |  
Rectifié | Rektifiziert

**120x278 . 47,24"x109,45"**  
**INF1757**

**Suggested grout**  
115 . River Grey





# infinito 2.0

GRAPHICS 120x278

304 INFINITO 2.0\_MARBLE EFFECT

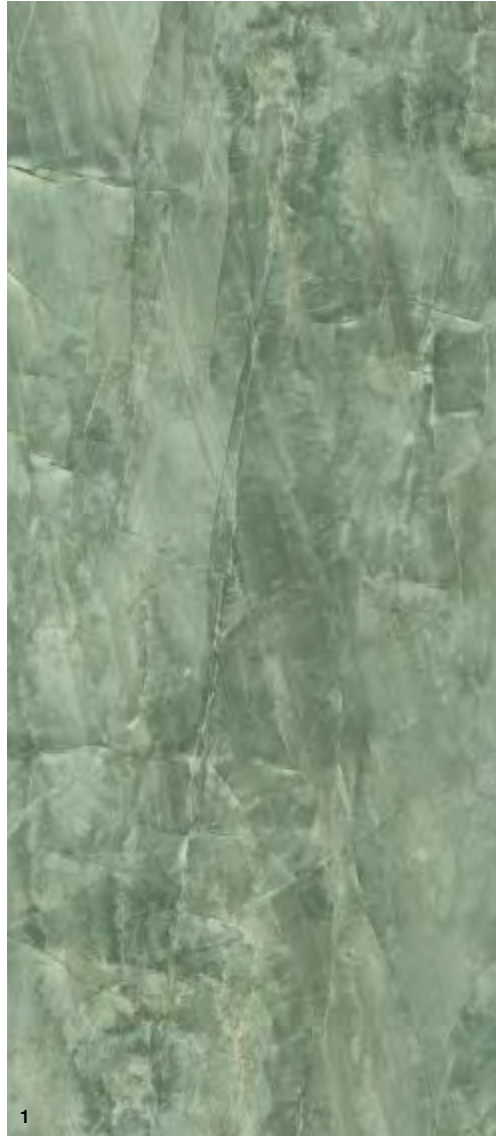

1

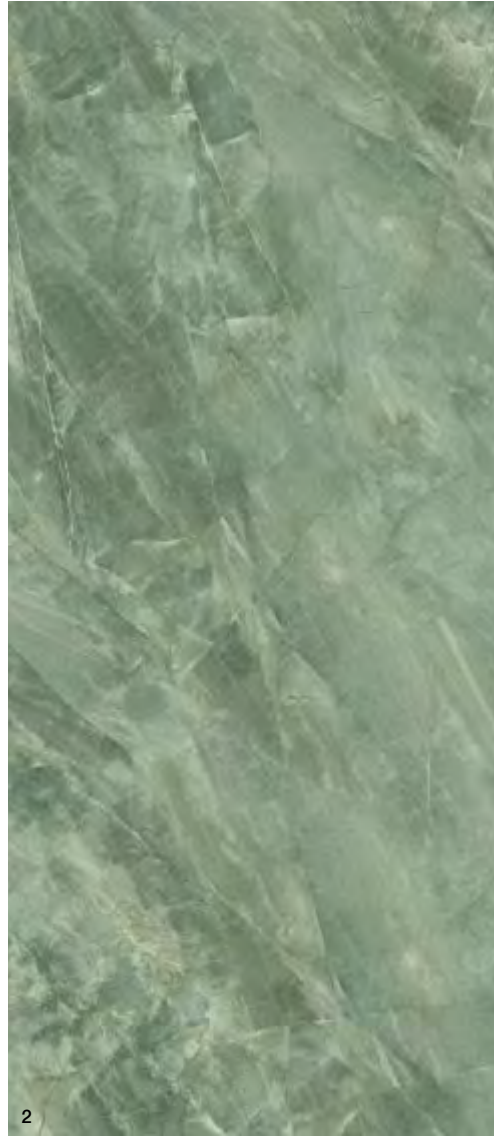

2

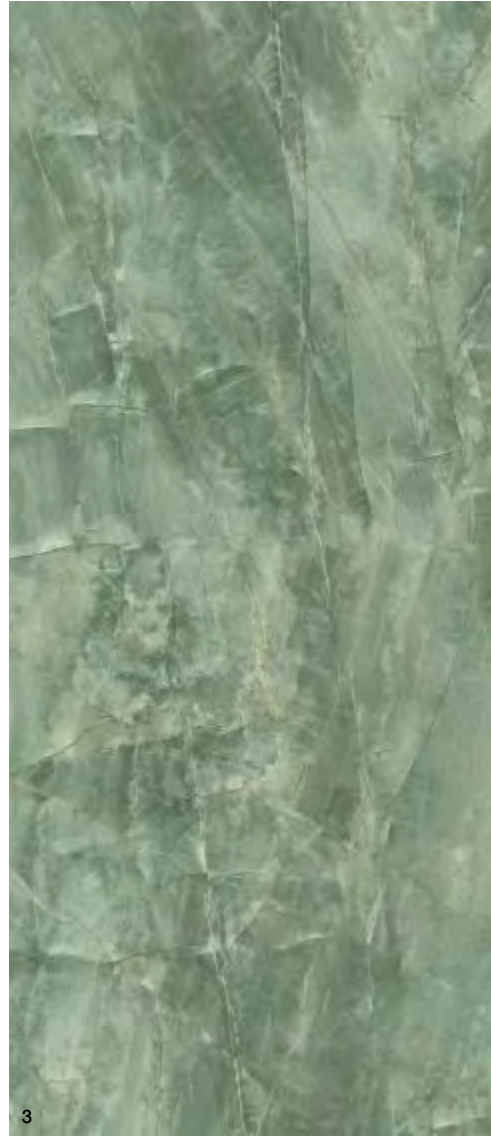

3

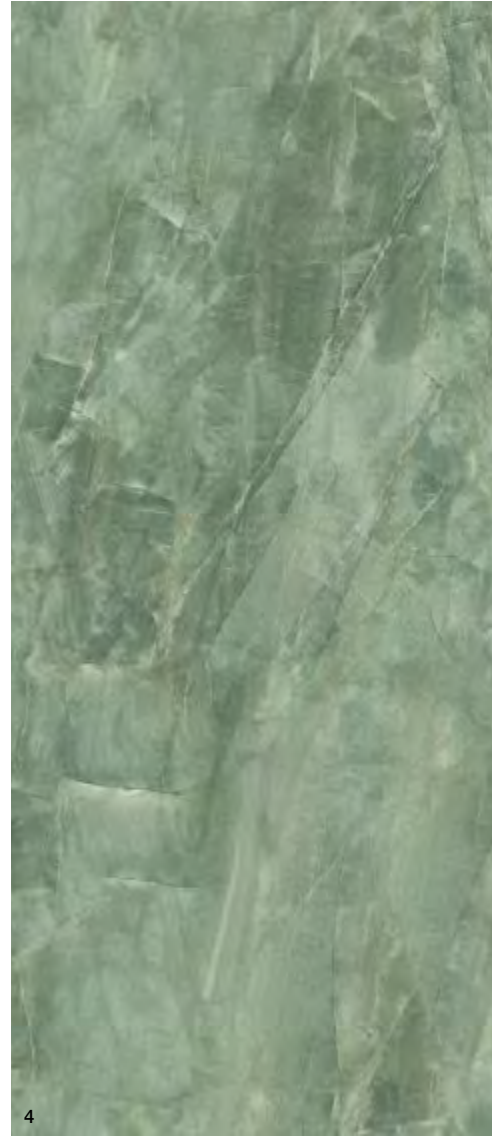

4

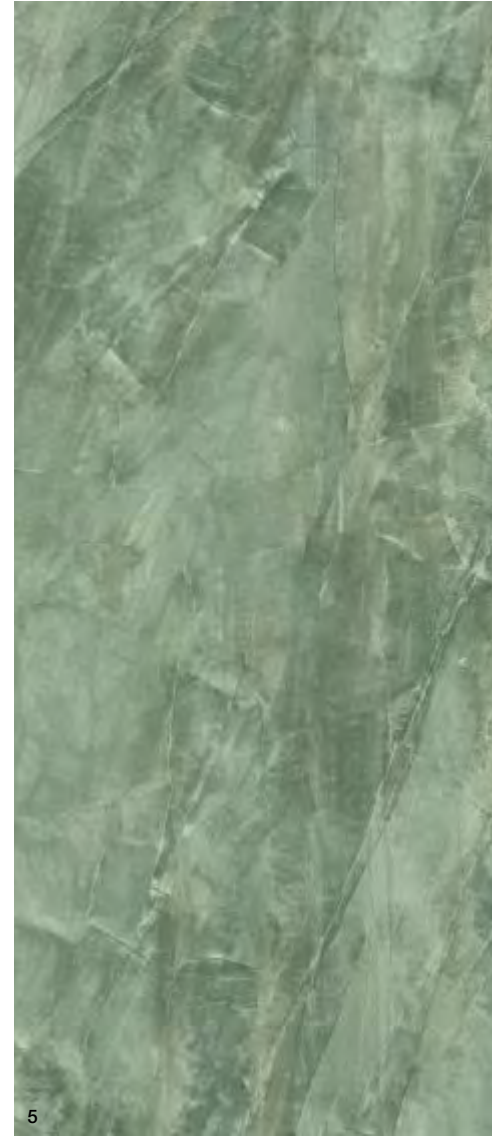

5

EMERALD GREEN

305 INFINITO 2.0\_MARBLE EFFECT

120x278 Prodotto con 5 diverse grafiche confezionate in modo casuale | Produced with a variety of a range of 5 different graphic designs which are randomly combined and then packed | Produit avec 5 différents graphismes conditionnés de façon fortuite | Mit 5 unterschiedlichen Graphiken hergestellt und mit einer zufälliger Auswahl verpackt





# infinito 2.0



RIVER JADE

SIZES & SURFACES



120x278\*\*  
47,24"x109,45"

6,5 mm

Glossy  
Rettificato | Rectified |  
Rectifié | Rektifiziert

120x278 . 47,24"x109,45"  
INF1886

Suggested grout  
111 . Silver Grey





# infinito 2.0

GRAPHICS 120x278



RIVER JADE

308 INFINITO 2.0\_MARBLE EFFECT

309 INFINITO 2.0\_MARBLE EFFECT

Nel formato 120x278 il "River Jade" è prodotto in 5 differenti facce per accentuare l'effetto naturale tipico del marmo. In fase di approntamento dell'ordine, la selezione delle facce è random, pertanto la venatura continuativa fra i diversi pezzi non è garantita. Rispettare la successione raffigurata per ricreare la sincronizzazione. La prima lastra raffigurata si aggancia alla quinta per garantire una soluzione infinita. L'effetto vena continua fra i diversi pezzi è soggetta alla tolleranza tipica del prodotto lapideo. | In the 120x278 size, "River Jade" is available with five different faces, to accentuate the natural look so typical of marble. When preparing the order, the different versions are chosen randomly, which means continuous veining between the different pieces is not guaranteed. Follow the sequence shown to recreate the synchronised effect. To ensure an endless finish, the sequence must be repeated continually, with the first slab placed after the fifth. The continuous veining effect across the various tiles is subject to the typical tolerance of stone products. | Dans le format 120x278 le "River Jade" est produit en 5 faces différentes pour accentuer l'effet naturel typique du marbre. Au moment de la préparation de la commande,

la sélection des faces est fortuite ; la continuité des veines entre les différentes pièces n'est donc pas garantie. Respecter la succession représentée pour recréer la synchronisation. La première dalle représentée s'accroche à la cinquième pour garantir une solution infinie. L'effet de la veine continue entre les différentes pièces est soumis à la tolérance typique du produit en pierre. | Beim Format 120x278 wird der "River Jade" in 5 verschiedenen Oberflächen hergestellt, um den natürlichen Effekt hervorzuheben, der für den Marmor typisch ist. Bei der Vorbereitung des Auftrags erfolgt die Auswahl der Oberflächen nach Zufall, weshalb die durchgehende Aderung zwischen den verschiedenen Teilen nicht garantiert ist. Halten Sie die dargestellte Reihenfolge ein, um die Synchronisierung nachzubilden. Die erste dargestellte Platte schließt sich an die fünfte an, um eine unendliche Lösung zu garantieren. Der Effekt der durchgehenden Aderung zwischen den verschiedenen Teilen unterliegt der typischen Toleranz des Produktes aus Stein.





# infinito 2.0



WHITE BEAUTY

SIZES & SURFACES



120x278\*\*  
47,24"x109,45"

**6,5 mm**

**Glossy**  
Rettificato | Rectified |  
Rectifié | Rektifiziert

**120x278 . 47,24"x109,45"**  
**INF1642**

**Suggested grout**  
103 . Moon White





# infinito 2.0

GRAPHICS 120x278

312 INFINITO 2.0\_MARBLE EFFECT



WHITE BEAUTY

313 INFINITO 2.0\_MARBLE EFFECT

120x278 Prodotto con 5 diverse grafiche confezionate in modo casuale | Produced with a variety of a range of 5 different graphic designs which are randomly combined and then packed | Produit avec 5 différents graphismes conditionnés de façon fortuite | Mit 5 unterschiedlichen Graphiken hergestellt und mit einer zufälliger Auswahl verpackt





# infinito 2.0



GREEN DENIS

### SIZES & SURFACES



120x278\*\*  
47,24"x109,45"

**6,5 mm**

**Glossy**  
Rettificato | Rectified |  
Rectifié | Rektifiziert

**120x278 . 47,24"x109,45"**  
**INF2270**

**Suggested grout**  
174 . Tornado





# infinito 2.0

GRAPHICS 120x278

316 INFINITO 2.0\_MARBLE EFFECT

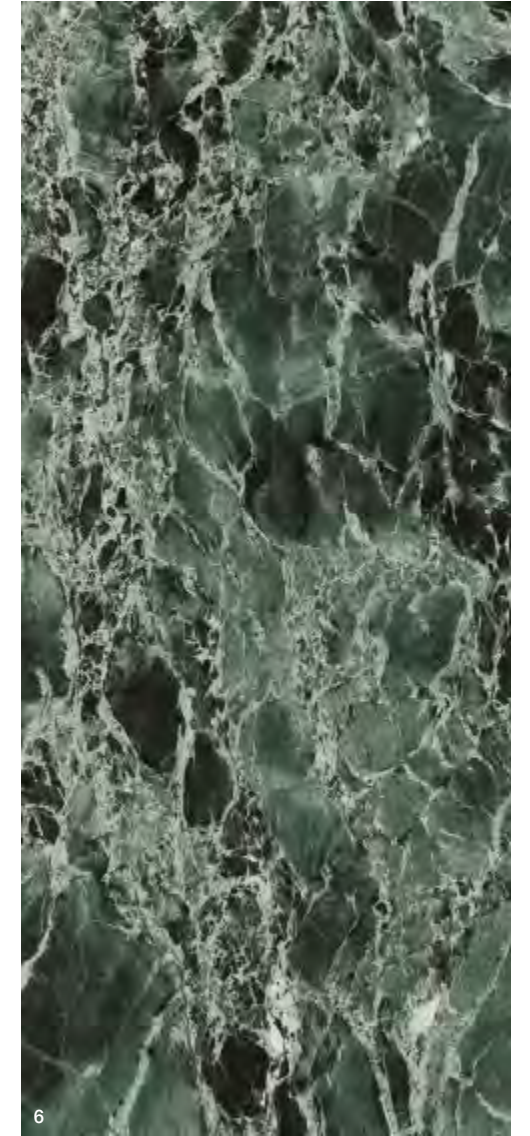
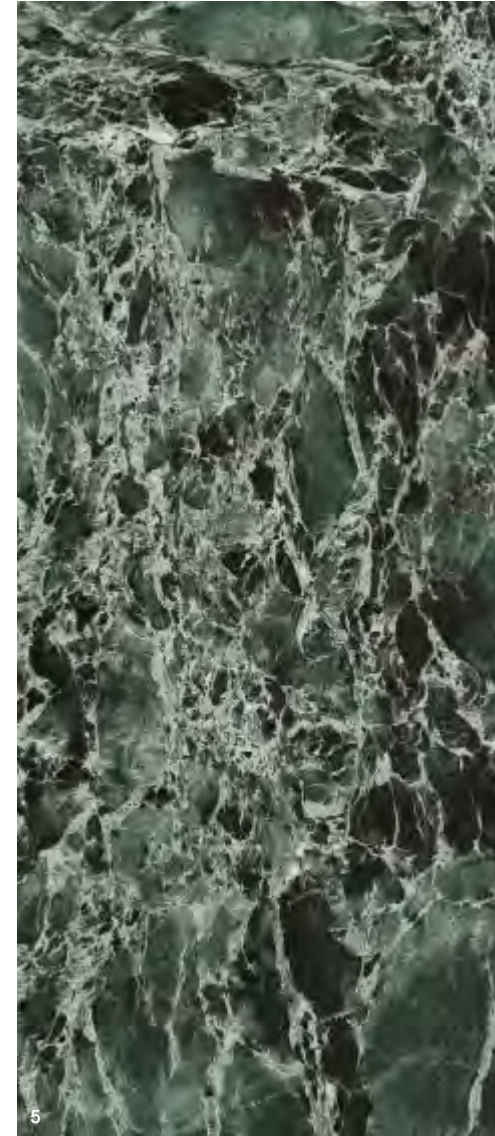

317 INFINITO 2.0\_MARBLE EFFECT

GREEN DENIS

120x278 Prodotto con 5 diverse grafiche confezionate in modo casuale | Produced with a variety of a range of 5 different graphic designs which are randomly combined and then packed | Produit avec 5 différents graphismes conditionnés de façon fortuite | Mit 5 unterschiedlichen Graphiken hergestellt und mit einer zufälliger Auswahl verpackt





# infito 2.0



SODALITE BLUE

SIZES & SURFACES



120x278\*\*  
47,24"x109,45"

6,5 mm

Glossy  
Rettificato | Rectified |  
Rectifié | Rektifiziert

120x278 . 47,24"x109,45"  
INF1633

Suggested grout  
172 . Space Blue





# infinito 2.0

GRAPHICS 120x278

320 INFINITO 2.0\_MARBLE EFFECT

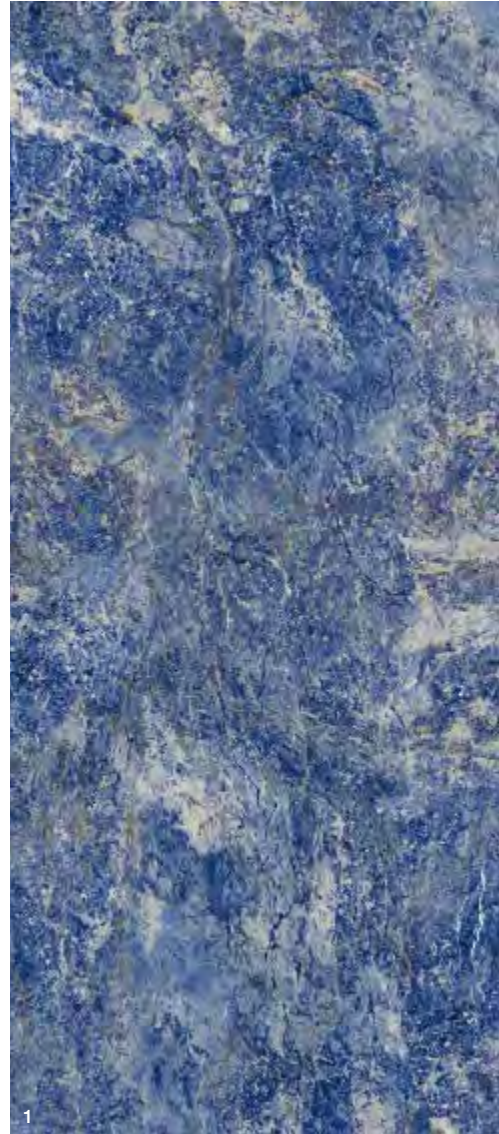

SODALITE BLUE

321 INFINITO 2.0\_MARBLE EFFECT

120x278 Prodotto con 5 diverse grafiche confezionate in modo casuale | Produced with a variety of a range of 5 different graphic designs which are randomly combined and then packed | Produit avec 5 différents graphismes conditionnés de façon fortuite | Mit 5 unterschiedlichen Graphiken hergestellt und mit einer zufälliger Auswahl verpackt



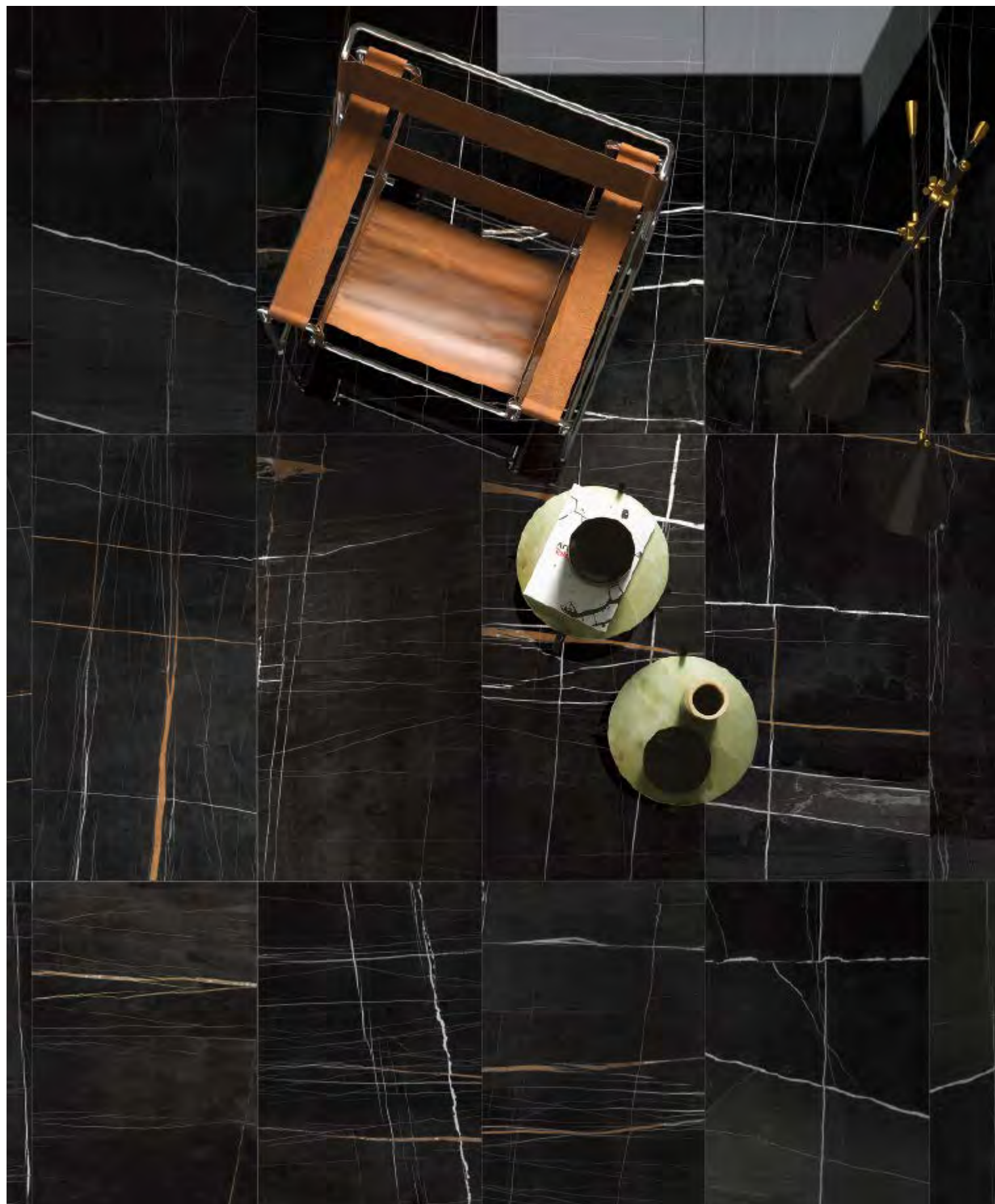

# infinito 2.0



SAHARA NOIR

SIZES & SURFACES

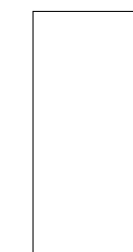

160x320\*  
62,99"x125,98"

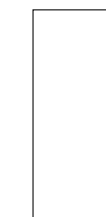

120x278\*\*  
47,24"x109,45"



60x120  
23,62"x47,24"

**6,5 mm**

Glossy  
Rettificato | Rectified |  
Rectifié | Rektifiziert

• 160x320 . 62,99"x125,98"  
**INF345**

120x278 . 47,24"x109,45"  
**INF1133**

60x120 . 23,62"x47,24"  
**INF830**

Honed  
Rettificato | Rectified |  
Rectifié | Rektifiziert

• 160x320 . 62,99"x125,98"  
**INF478**

120x278 . 47,24"x109,45"  
**INF1132**

• Disponibile su richiesta | Available on request | Disponible sur demande |  
Auf Anfrage erhältlich

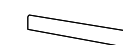

6,5 mm  
8x120 . 3,15"x47,24"  
battiscopa  
**INF314** glossy

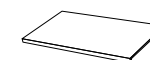

6,5 mm  
33x120x5 . 12,99"x47,24"x1,97"  
gradino lineare LL  
**INF586** glossy

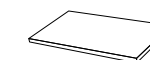

6,5 mm  
33x120x5 . 12,99"x47,24"x1,97"  
gradino angolare LL  
**INF588** glossy

Suggested grout  
120 . Black





# infinito 2.0

GRAPHICS 120x278

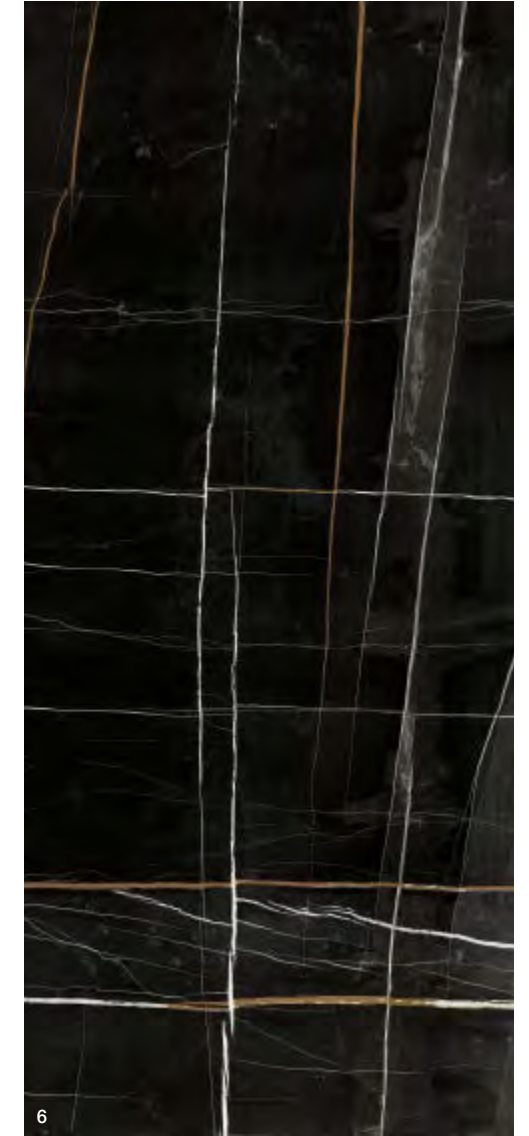
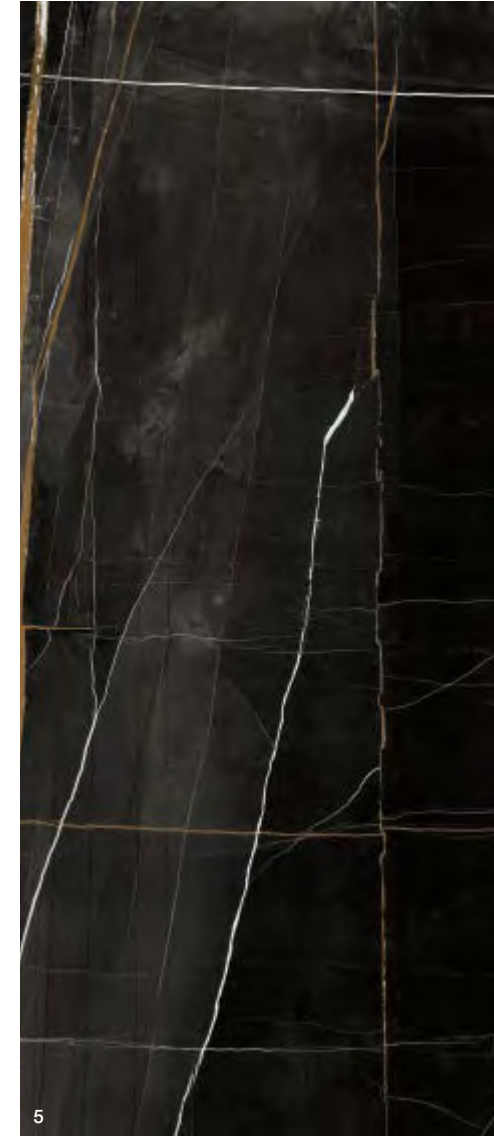
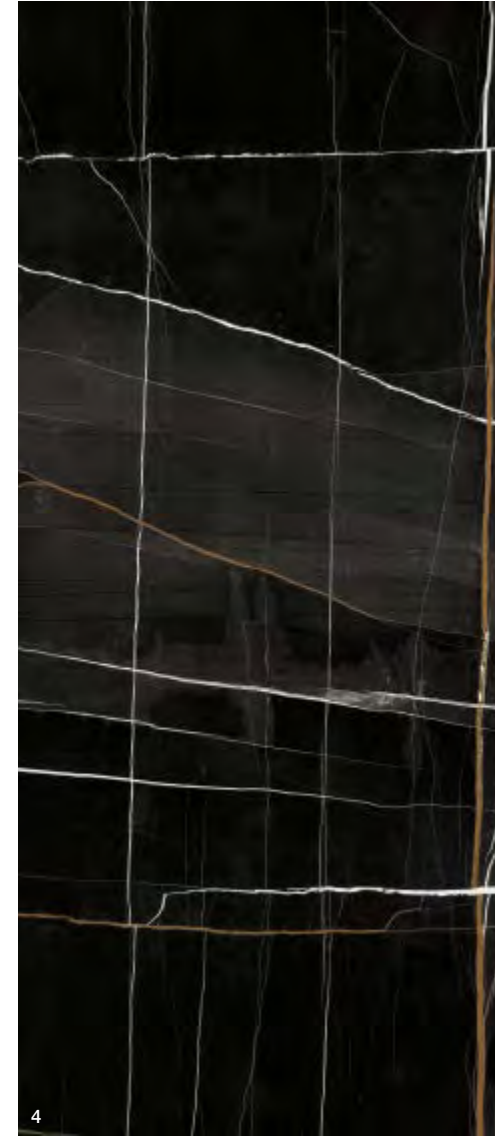
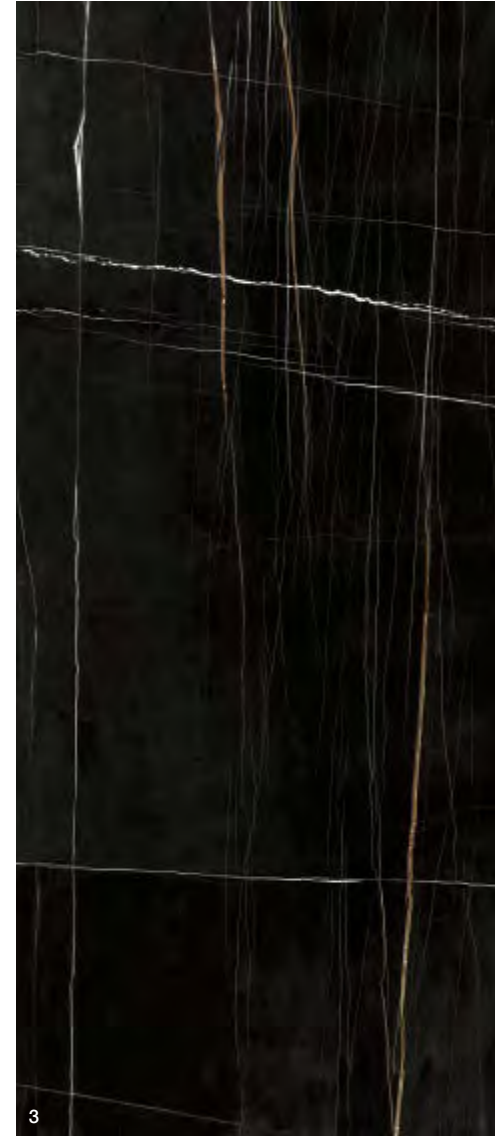
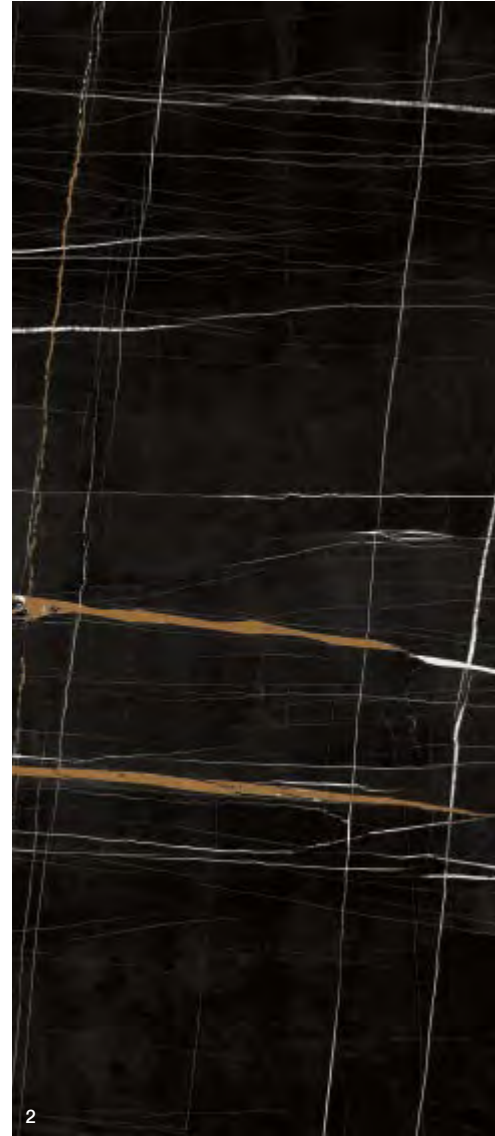
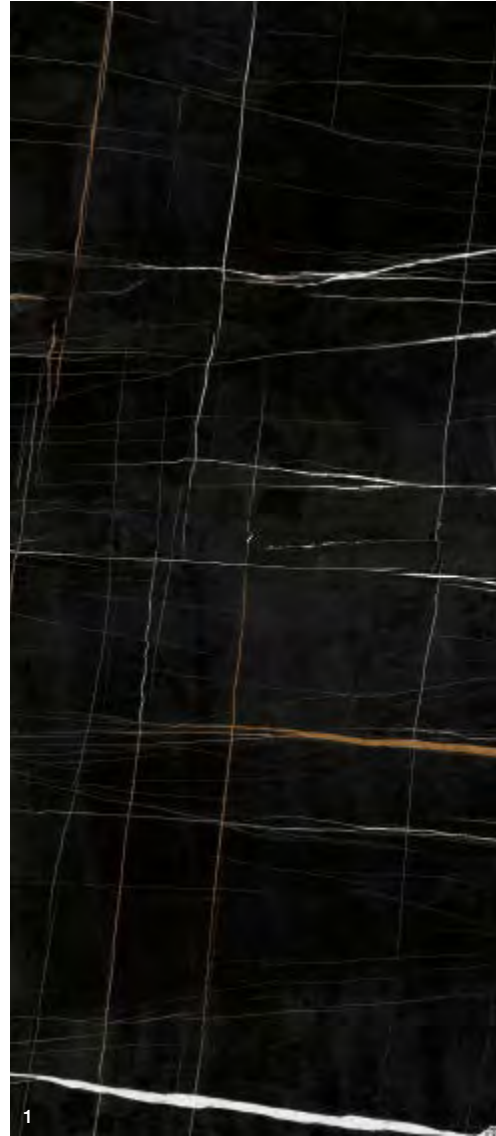

SAHARA NOIR

324 INFINITO 2.0\_MARBLE EFFECT

325 INFINITO 2.0\_MARBLE EFFECT

120x278\_Prodotto con 6 diverse grafiche confezionate in modo casuale | Produced with a variety of a range of 6 different graphic designs which are randomly combined and then packed | Produit avec 6 différents graphismes conditionnés de façon fortuite | Mit 6 unterschiedlichen Graphiken hergestellt und mit einer zufälliger Auswahl verpackt

La nuova tecnologia adottata da Fondovalle per la produzione delle lastre aumenta considerevolmente lo spessore della materia lavorata meccanicamente per ottenere le finiture Glossy / Honed. Queste materie prime conferiscono un aspetto unico alla superficie ed una eccellente durabilità. Per il colore Sahara Noir, possono indurre la formazione di lievi spillature che sono da considerarsi come connaturate al materiale. | The new technology adopted by Fondovalle in its production slabs considerably increases the thickness of material which is processed mechanically to obtain the glossy/honed finishes. These raw materials lend the tiles a unique appearance and excellent durability. In the Sahara Noir option, they can cause the formation of light specks of colour, which should be considered a natural feature of the material. | La nouvelle technologie adoptée par Fondovalle pour la production de plaques augmente considérablement l'épaisseur de la matière traitée mécaniquement pour obtenir les finitions glossy / Honed. Ces matières premières donnent à la surface un aspect unique et une excellente durabilité. Pour la couleur Sahara Noir, elles peuvent déclencher la formation de légères taches inhérentes au matériau. | Die neue Technologie, die von Fondovalle zur Herstellung von Platten angewandt wird, erhöht die Stärke des zur Erzielung der polierten / geschliffenen Oberflächen mechanisch bearbeiteten Materials erheblich. Diese Rohstoffe verleihen der Oberfläche ein einzigartiges Aussehen und eine hervorragende Haltbarkeit. Bei der Farbe Sahara Noir können sie zur Bildung von leichten Punkten führen, die als für das Material typisch anzusehen sind.



# infinito 2.0

GRAPHICS 160x320

326 INFINITO 2.0\_MARBLE EFFECT



1

SAHARA NOIR

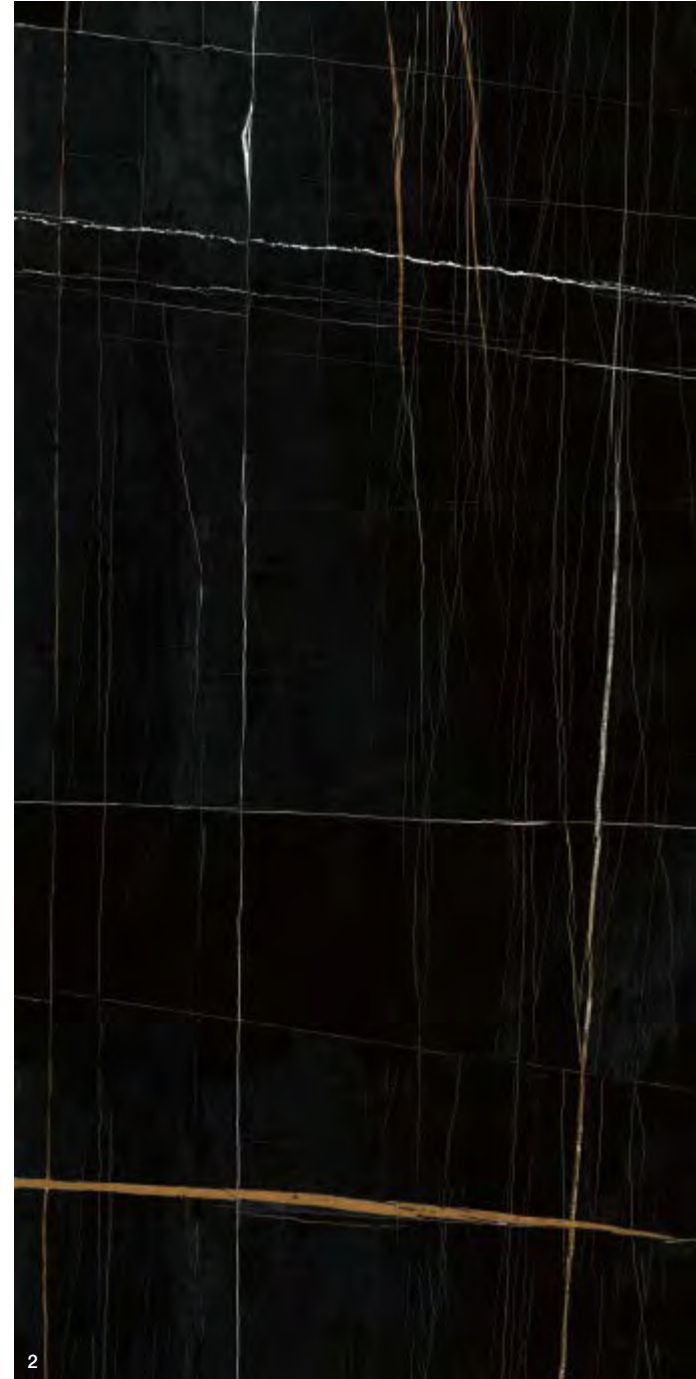

2

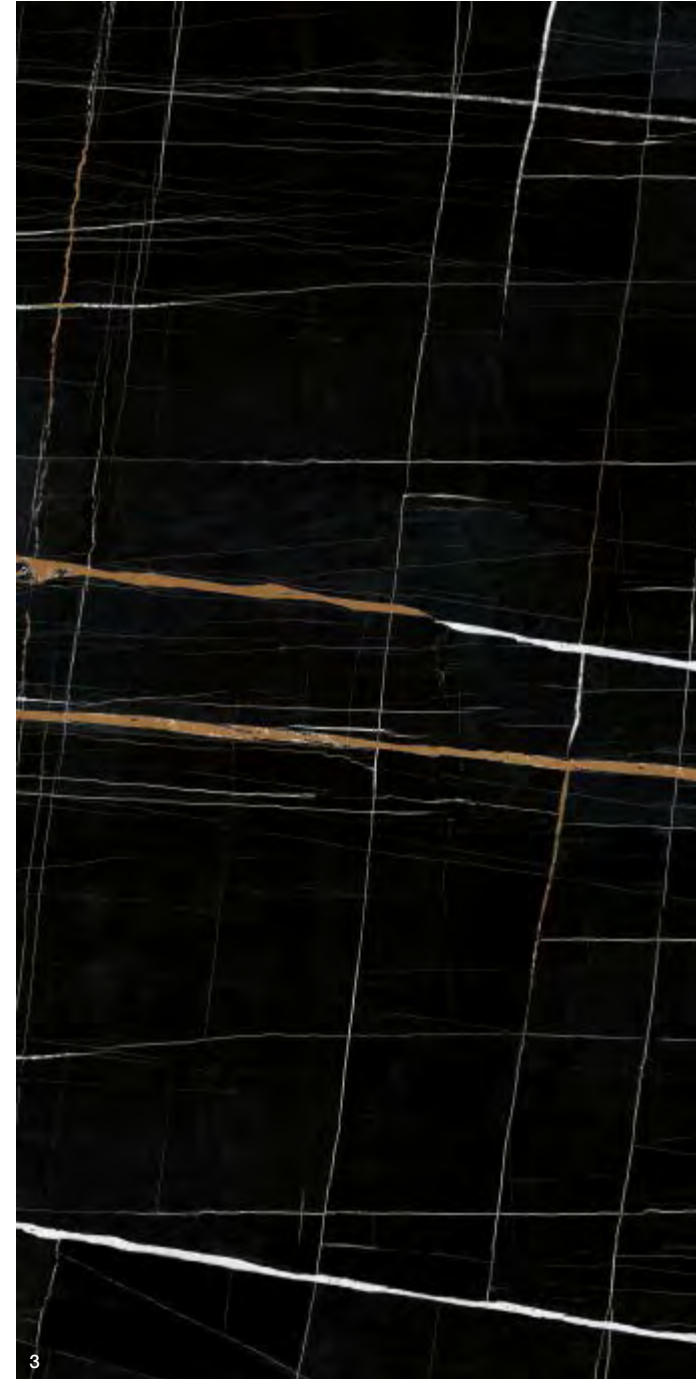

3

327 INFINITO 2.0\_MARBLE EFFECT

160x320\_Prodotto con 3 diverse grafiche confezionate in modo casuale | Produced with a variety of a range of 3 different graphic designs which are randomly combined and then packed | Produit avec 3 différents graphismes conditionnés de façon fortuite | Mit 3 unterschiedlichen Graphiken hergestellt und mit einer zufälliger Auswahl verpackt





# infinito 2.0



PORT LAURENT

### SIZES & SURFACES



**120x278\*\***  
47,24"x109,45"



**60x120**  
23,62"x47,24"

**6,5 mm**

**Glossy**  
Rettificato | Rectified |  
Rectifié | Rektifiziert

**120x278** . 47,24"x109,45"  
**INF1731**

**60x120** . 23,62"x47,24"  
**INF1736**

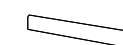

**6,5 mm**  
**8x120** . 3,15"x47,24"  
battiscopa  
**INF1737** glossy

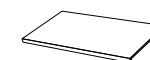

**6,5 mm**  
**33x120x5** . 12,99"x47,24"x1,97"  
gradino lineare LL  
**INF1738** glossy

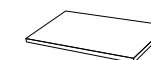

**6,5 mm**  
**33x120x5** . 12,99"x47,24"x1,97"  
gradino angolare LL  
**INF1739** glossy

**Suggested grout**  
120 . Black





# infinito 2.0

GRAPHICS 120x278

330 INFINITO 2.0\_MARBLE EFFECT

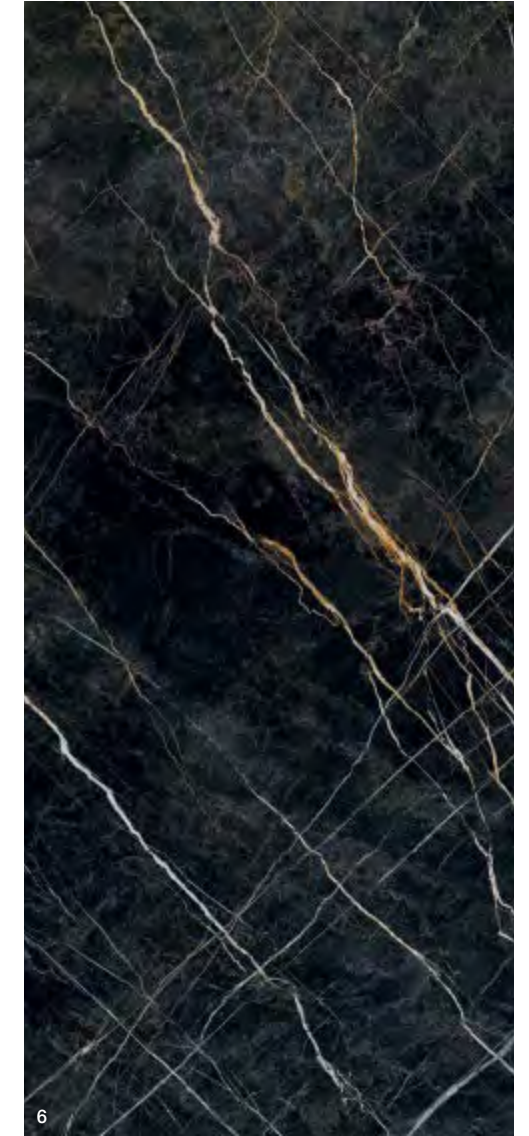
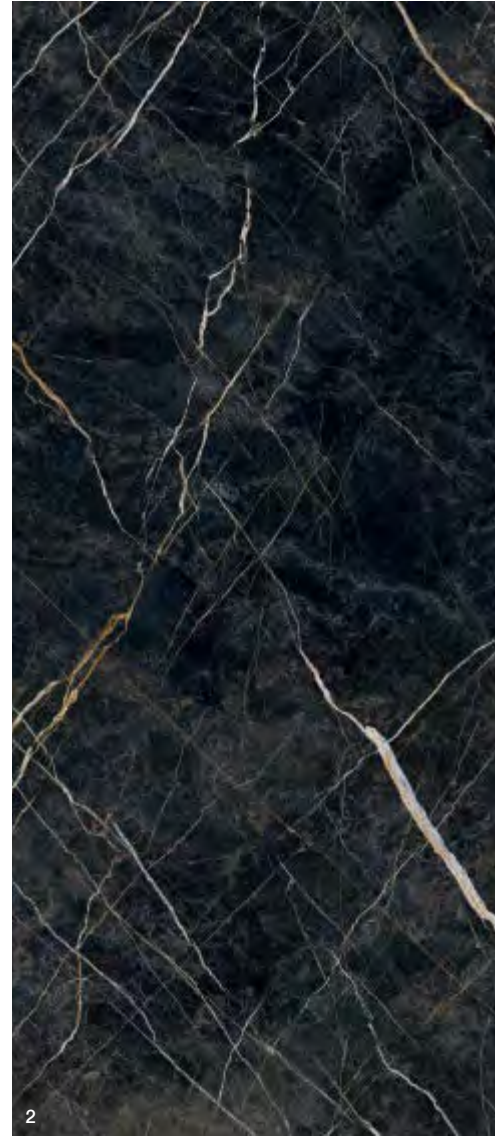
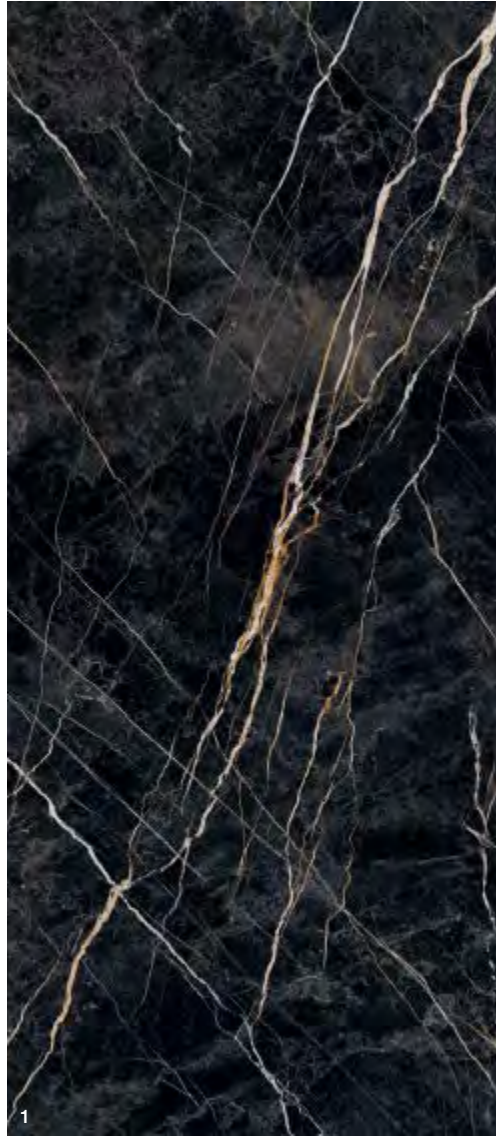

331 INFINITO 2.0\_MARBLE EFFECT

PORT LAURENT

120x278\_Prodotto con 6 diverse grafiche confezionate in modo casuale | Produced with a variety of a range of 6 different graphic designs which are randomly combined and then packed | Produit avec 6 différents graphismes conditionnés de façon fortuite | Mit 6 unterschiedlichen Graphiken hergestellt und mit einer zufälliger Auswahl verpackt





# infinito 2.0

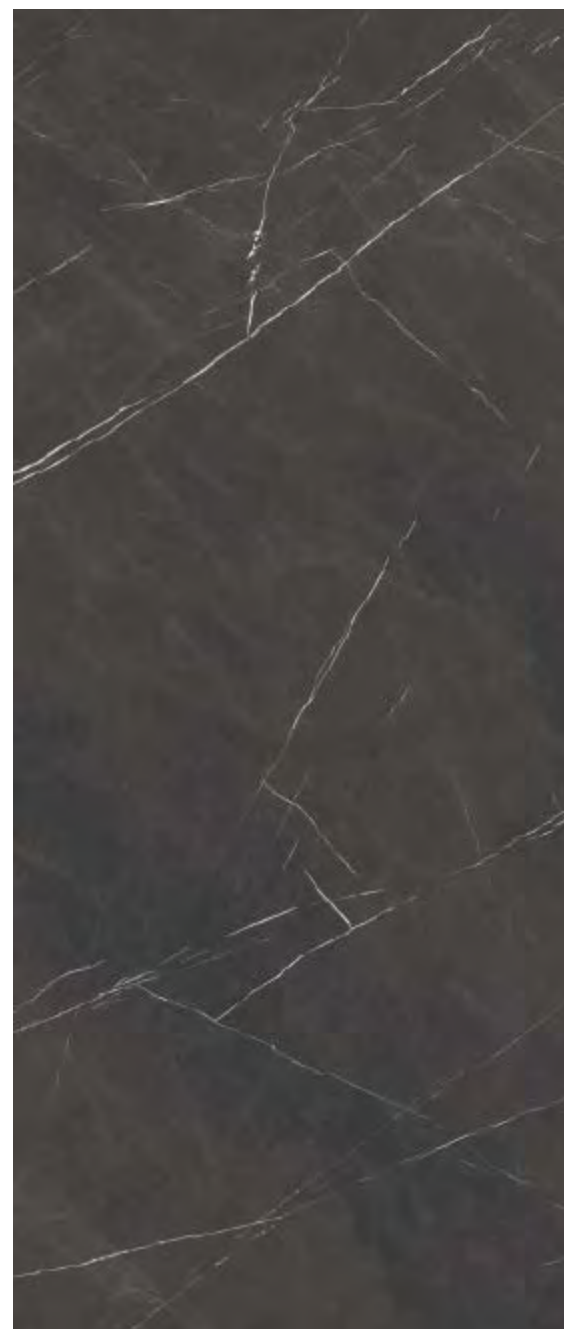

PIETRA GREY

### SIZES & SURFACES



120x278\*\*  
47,24"x109,45"

**6,5 mm**

**Natural**  
Rettificato | Rectified |  
Rectifié | Rektifiziert

**120x278 . 47,24"x109,45"**  
**INF1925**

**Suggested grout**  
120 . Black





# infinito 2.0

GRAPHICS 120x278

334 INFINITO 2.0\_MARBLE EFFECT

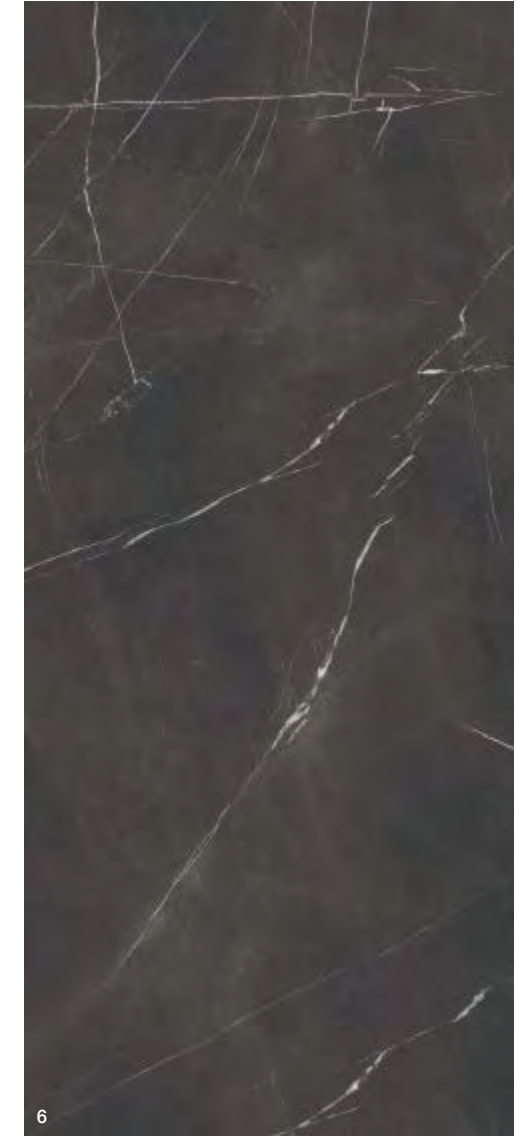
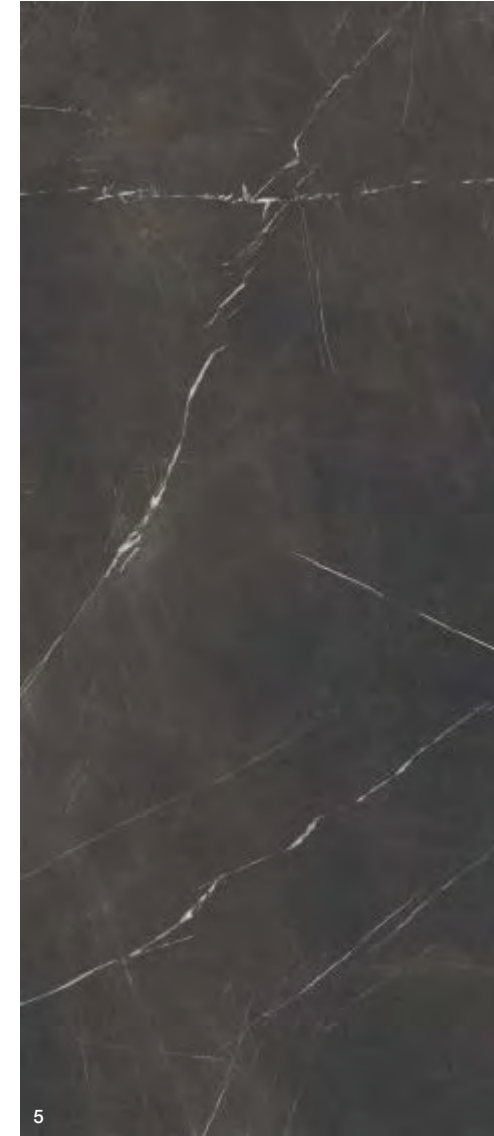
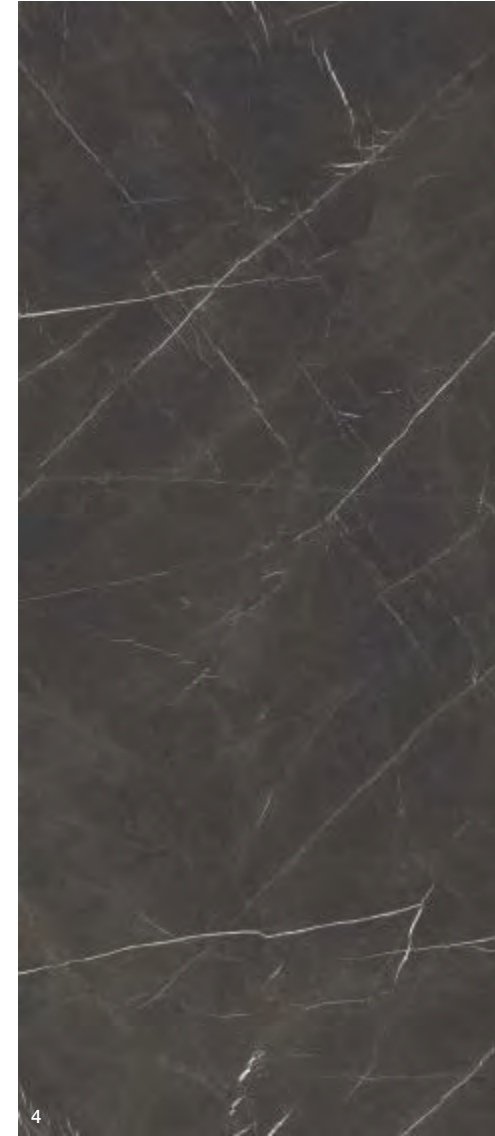
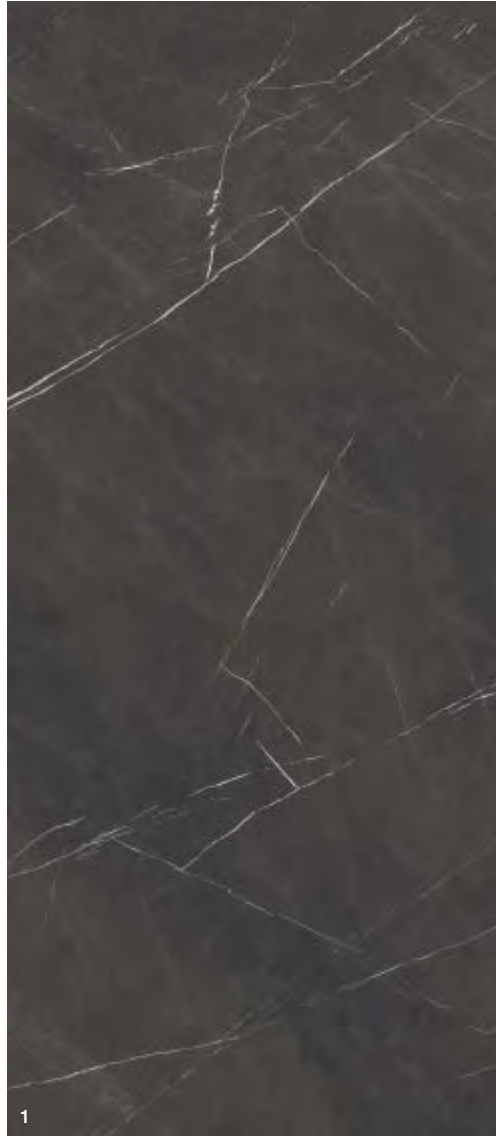

335 INFINITO 2.0\_MARBLE EFFECT

PIETRA GREY

120x278\_Prodotto con 6 diverse grafiche confezionate in modo casuale | Produced with a variety of a range of 6 different graphic designs which are randomly combined and then packed | Produit avec 6 différents graphismes conditionnés de façon fortuite | Mit 6 unterschiedlichen Graphiken hergestellt und mit einer zufälliger Auswahl verpackt



# infinito 2.0

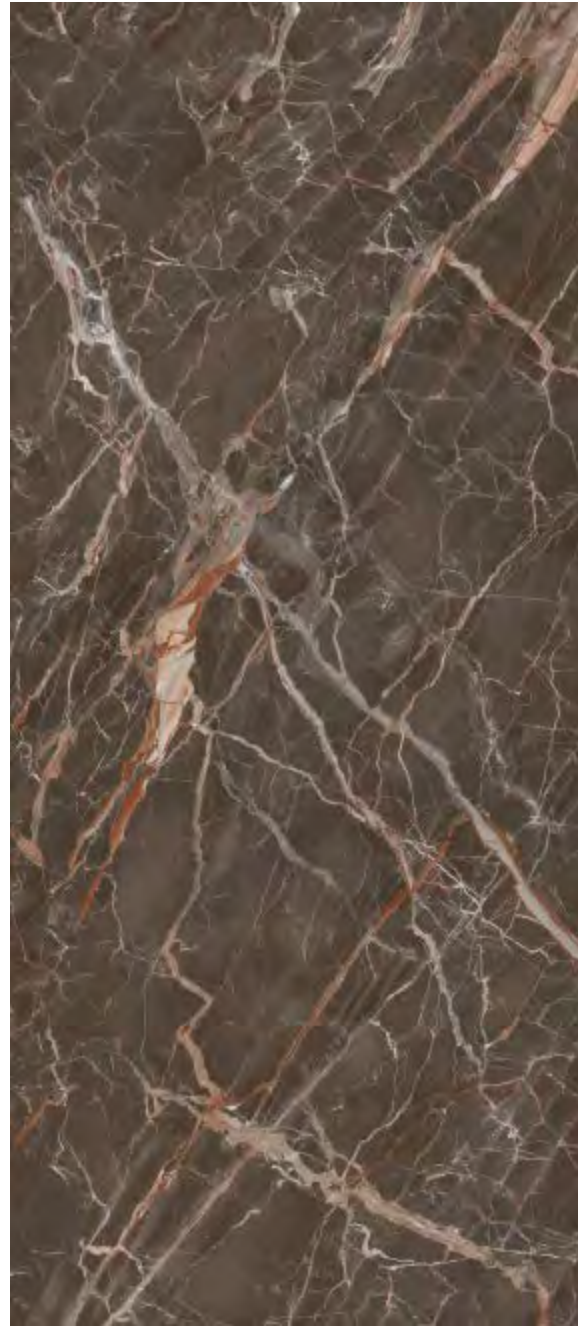

## SIZES & SURFACES



**160x320\***  
62,99"x125,98"



**120x278\*\***  
47,24"x109,45"



**60x120**  
23,62"x47,24"

### 6,5 mm

**Glossy**  
Rettificato | Rectified |  
Rectifié | Rektifiziert

- **160x320** . 62,99"x125,98"  
**INF872**

**120x278** . 47,24"x109,45"  
**INF1141**

**60x120** . 23,62"x47,24"  
**INF868**

**Honed**  
Rettificato | Rectified |  
Rectifié | Rektifiziert

- **160x320** . 62,99"x125,98"  
**INF871**

**120x278** . 47,24"x109,45"  
**INF1140**

- Disponibile su richiesta | Available on request | Disponible sur demande | Auf Anfrage erhältlich

OMBRA DI CARAVAGGIO

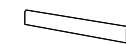

**6,5 mm**  
**8x120** . 3,15"x47,24"  
battiscopa  
**INF915** glossy



**6,5 mm**  
**33x120x5** . 12,99"x47,24"x1,97"  
gradino lineare LL  
**INF921** glossy



**6,5 mm**  
**33x120x5** . 12,99"x47,24"x1,97"  
gradino angolare LL  
**INF924** glossy

**Suggested grout**  
136 . Mud

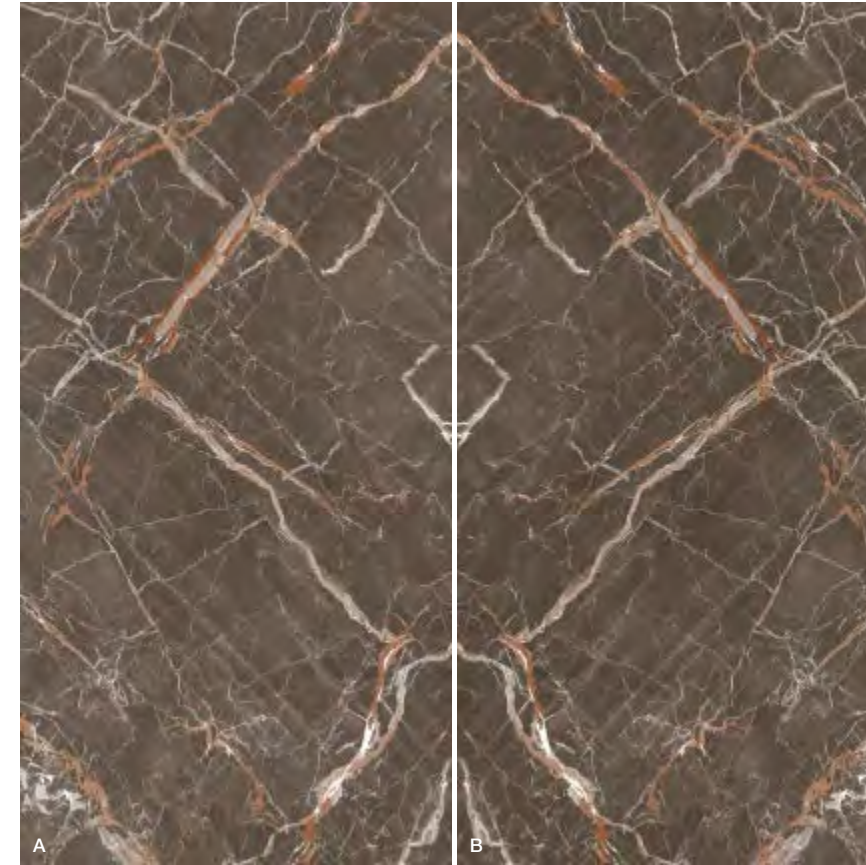

OMBRA DI CARAVAGGIO

## LAYING EXAMPLE

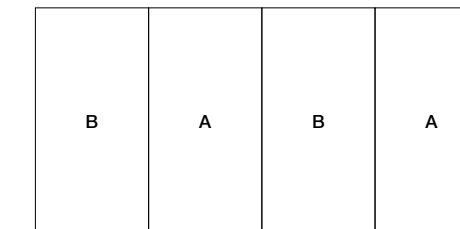
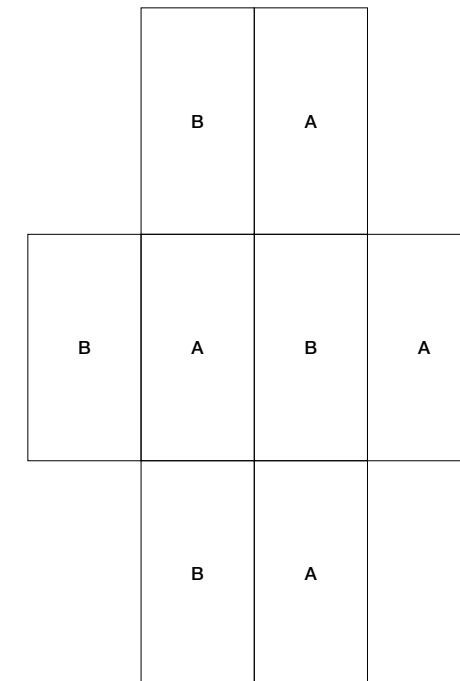

La grafica dell'Ombra di Caravaggio Bookmatch consente di ricreare delle composizioni infinite perchè le venature combaciano sia verticalmente che orizzontalmente. Per ottenere questi effetti speculari, è importante seguire la successione delle lettere come nel disegno proposto. L'effetto Bookmatch tra le diverse lastre è soggetto alla tolleranza tipica del prodotto lapideo. | The aesthetic features of Ombra di Caravaggio Bookmatch allow users to recreate endless designs since the veining matches both horizontally and vertically. To ensure this seamless effect, it is important to follow the sequence of letters shown in the design given. The bookmatching effect created by placing different slabs together is subject to the usual joint specifications of stone tiles. | Le graphisme du Ombra di Caravaggio Bookmatch permet de recréer des compositions infinies parce que les veines coïncident verticalement et horizontalement. Pour obtenir ces effets spéculaire, il est important de suivre la succession des lettres d'après le dessin proposé. L'effet Bookmatch entre différentes dalles est soumis à la tolérance typique du produit en pierre. | Die Grafik des Ombra di Caravaggio Bookmatch ermöglicht die Bildung von unendlich vielen Zusammenstellungen, da die Aderungen sowohl vertikal als auch horizontal aneinander passen. Zur Erzielung dieser spiegelbildlichen Effekte ist es wichtig, die Buchstaben nacheinander auszuführen, wie in der vorgeschlagenen Zeichnung. Der Effekt des Bookmatching zwischen den verschiedenen Platten unterliegt der typischen Toleranz des Produktes aus Stein.



# infinito 2.0

GRAPHICS 120x278

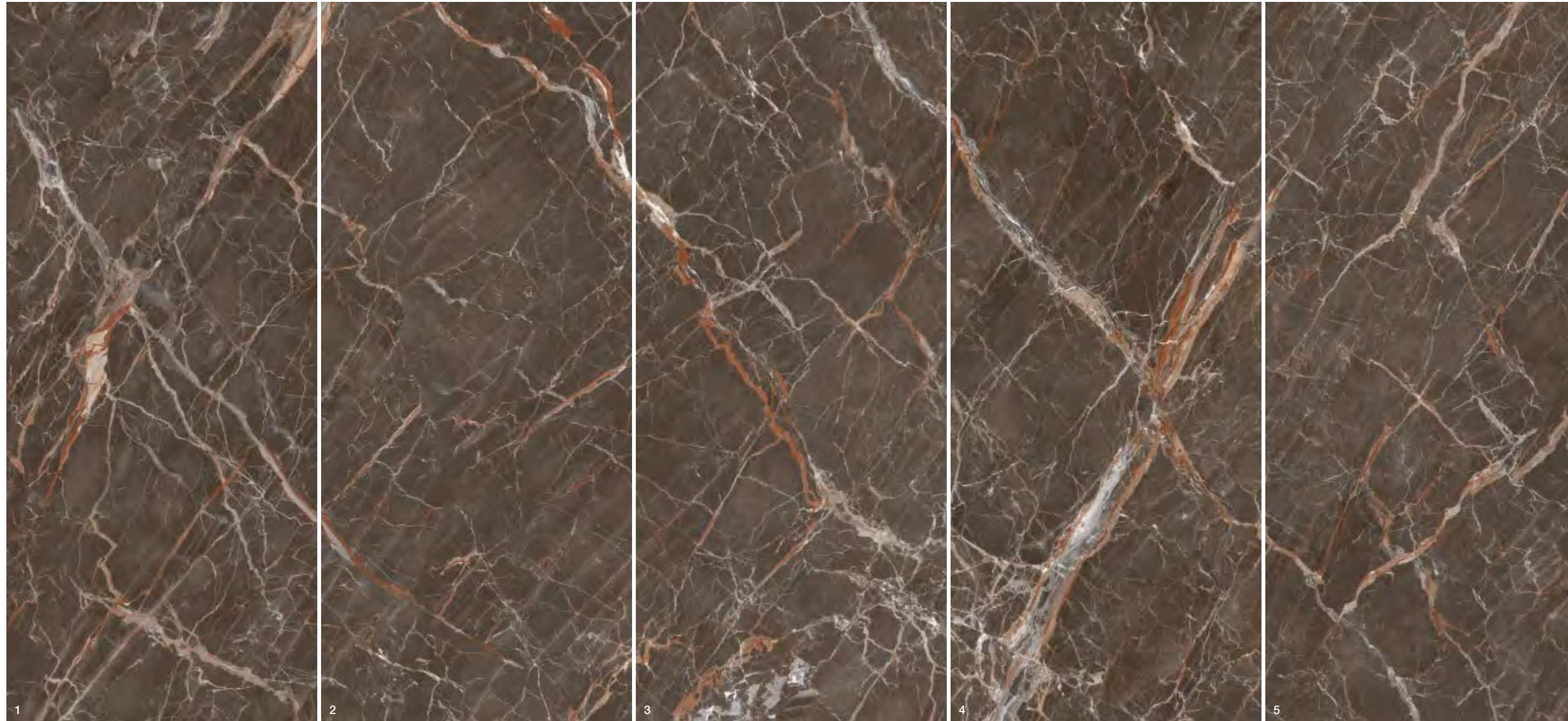

OMBRA DI CARAVAGGIO

Nel formato 120x278 l'“Ombra di Caravaggio” è prodotto in 5 differenti facce per accentuare l'effetto naturale tipico del marmo. In fase di approntamento dell'ordine, la selezione delle facce è random, pertanto la venatura continuativa fra i diversi pezzi non è garantita. Rispettare la successione raffigurata per ricreare la sincronizzazione. La prima lastra raffigurata si aggancia alla quinta per garantire una soluzione infinita. L'effetto vena continua fra i diversi pezzi è soggetta alla tolleranza tipica del prodotto lapideo. | In the 120x278 size, “Ombra di Caravaggio” is available with five different faces, to accentuate the natural look so typical of marble. When preparing the order, the different versions are chosen randomly, which means continuous veining between the different pieces is not guaranteed. Follow the sequence shown to recreate the synchronised effect. To ensure an endless finish, the sequence must be repeated continually, with the first slab placed after the fifth. The continuous veining effect across the various tiles is subject to the typical tolerance of stone products. | Dans le format 120x278 le “Ombra di Caravaggio” est produit en 5 faces différentes pour accentuer l'effet naturel typique du marbre. Au moment de la

préparation de la commande, la sélection des faces est fortuite ; la continuité des veines entre les différentes pièces n'est donc pas garantie. Respecter la succession représentée pour recréer la synchronisation. La première dalle représentée s'accroche à la cinquième pour garantir une solution infinie. L'effet de la veine continue entre les différentes pièces est soumis à la tolérance typique du produit en pierre. | Beim Format 120x278 wird der “Ombra di Caravaggio” in 5 verschiedenen Oberflächen hergestellt, um den natürlichen Effekt hervorzuheben, der für den Marmor typisch ist. Bei der Vorbereitung des Auftrags erfolgt die Auswahl der Oberflächen nach Zufall, weshalb die durchgehende Aderung zwischen den verschiedenen Teilen nicht garantiert ist. Halten Sie die dargestellte Reihenfolge ein, um die Synchronisierung nachzubilden. Die erste dargestellte Platte schließt sich an die fünfte an, um eine unendliche Lösung zu garantieren. Der Effekt der durchgehenden Aderung zwischen den verschiedenen Teilen unterliegt der typischen Toleranz des Produktes aus Stein.



# infinito 2.0

GRAPHICS 160x320

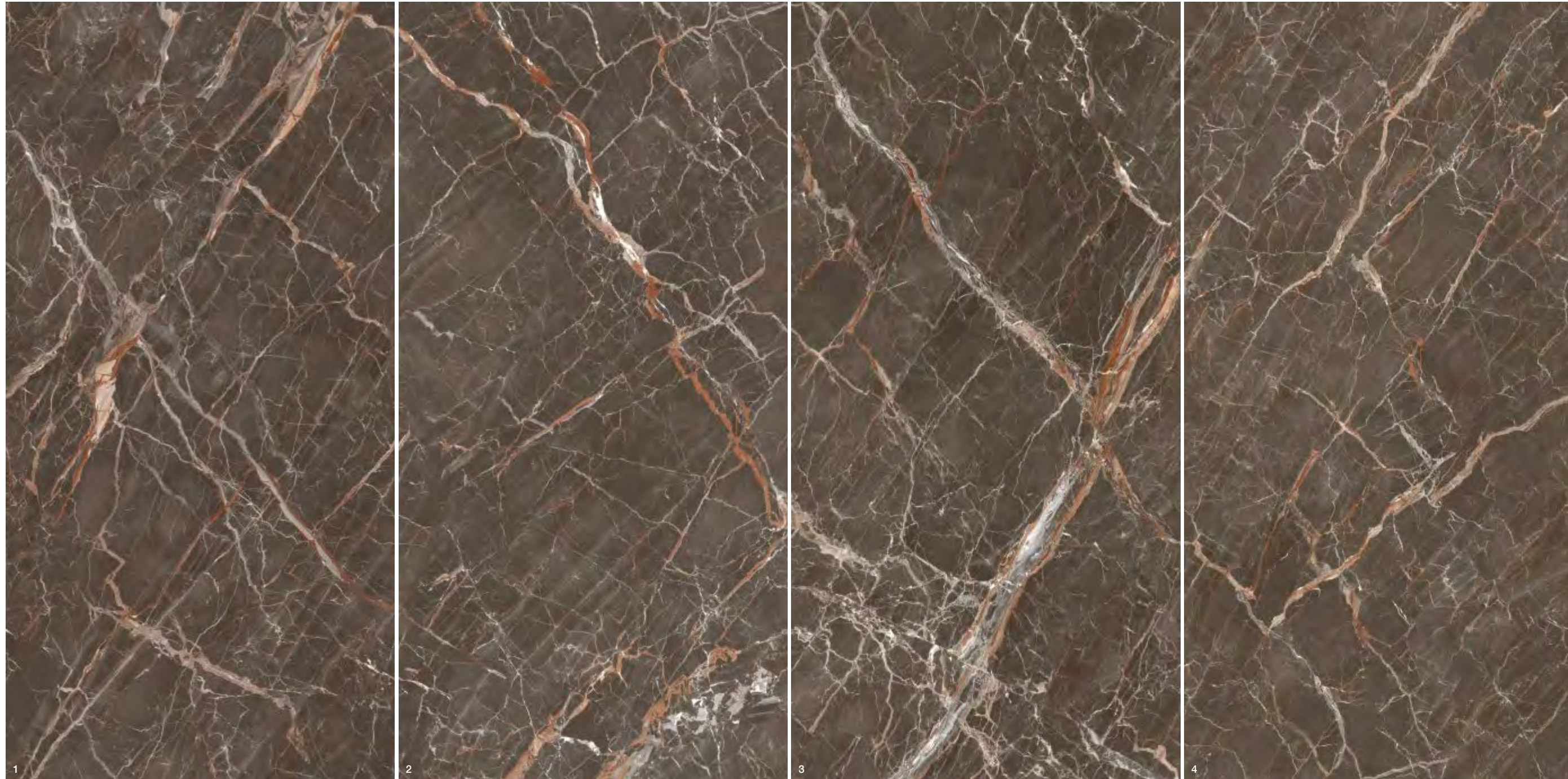

340 INFINITO 2.0\_MARBLE EFFECT

341 INFINITO 2.0\_MARBLE EFFECT

## OMBRA DI CARAVAGGIO

Nel formato 160x320 l'“Ombra di Caravaggio” è prodotto in 4 differenti facce per accentuare l'effetto naturale tipico del marmo. In fase di approntamento dell'ordine, la selezione delle facce è random, pertanto la venatura continuativa fra i diversi pezzi non è garantita. Rispettare la successione raffigurata per ricreare la sincronizzazione. La prima lastra raffigurata si aggancia alla quarta per garantire una soluzione infinita. L'effetto vena continua fra i diversi pezzi è soggetta alla tolleranza tipica del prodotto lapideo. | In the 160x320 size, “Ombra di Caravaggio” is available with four different faces, to accentuate the natural look so typical of marble. When preparing the order, the different versions are chosen randomly, which means continuous veining between the different pieces is not guaranteed. Follow the sequence shown to recreate the synchronised effect. To ensure an endless finish, the sequence must be repeated continually, with the first slab placed after the fourth. The continuous veining effect across the various tiles is subject to the typical tolerance of stone products. | Dans le format 160x320 le “Ombra di Caravaggio” est produit en 4 faces différentes pour accentuer l'effet naturel typique du marbre. Au moment de la préparation de la commande, la sélection des

faces est fortuite ; la continuité des veines entre les différentes pièces n'est donc pas garantie. Respecter la succession représentée pour recréer la synchronisation. La première dalle représentée s'accroche à la quatrième pour garantir une solution infinie. L'effet de la veine continue entre les différentes pièces est soumis à la tolérance typique du produit en pierre. | Beim Format 160x320 wird der “Ombra di Caravaggio” in 4 verschiedenen Oberflächen hergestellt, um den natürlichen Effekt hervorzuheben, der für den Marmor typisch ist. Bei der Vorbereitung des Auftrags erfolgt die Auswahl der Oberflächen nach Zufall, weshalb die durchgehende Aderung zwischen den verschiedenen Teilen nicht garantiert ist. Halten Sie die dargestellte Reihenfolge ein, um die Synchronisierung nachzubilden. Die erste dargestellte Platte schließt sich an die vierte an, um eine unendliche Lösung zu garantieren. Der Effekt der durchgehenden Aderung zwischen den verschiedenen Teilen unterliegt der typischen Toleranz des Produktes aus Stein.





Effetto Pietra  
Effet Pierre  
Stein-Effekt

## stone effect

- 344 Background
- 362 Royal Travertino
- 376 Upper
- 390 Keynote
- 402 Reframe
- 412 Shards
- 422 Planeto
- 454 StoneLab



344 BACKGROUND\_STONE EFFECT



# background



Lastre / piastrelle di ceramica in gres porcellanato - Gruppo Bla UGL  
Porcelain stoneware slabs / tiles - Gruppe Bla UGL  
Dalles / carreaux en céramique en grès cérame - Group Bla UGL  
Keramikplatten / keramikfliesen aus Feinsteinzeug - Gruppe Bla UGL

### THICKNESS



6,5 mm SELF LEVELING 8,5 mm

### SURFACES

Real Matt  
3D Texture (Empaire)  
Rettificato | Rectified |  
Rectifié | Rektifiziert

### TECH INFO

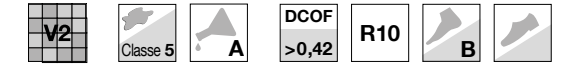

BS EN 16165\_C >  
Dry & Wet rubber 4S: ≥ 36  
AS 4586 > P3  
UNE-ENV 12633 > Class 2

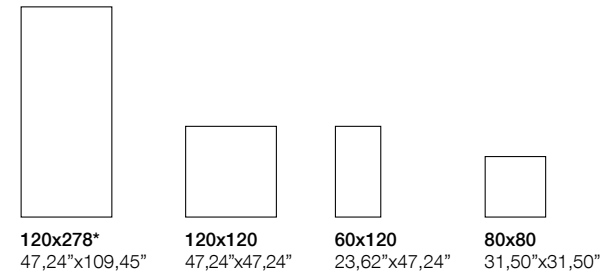

\* Lastre realizzate attraverso impasti colorati con colori standard | Slabs produced using coloured body mix available in standard shades

### COLORS

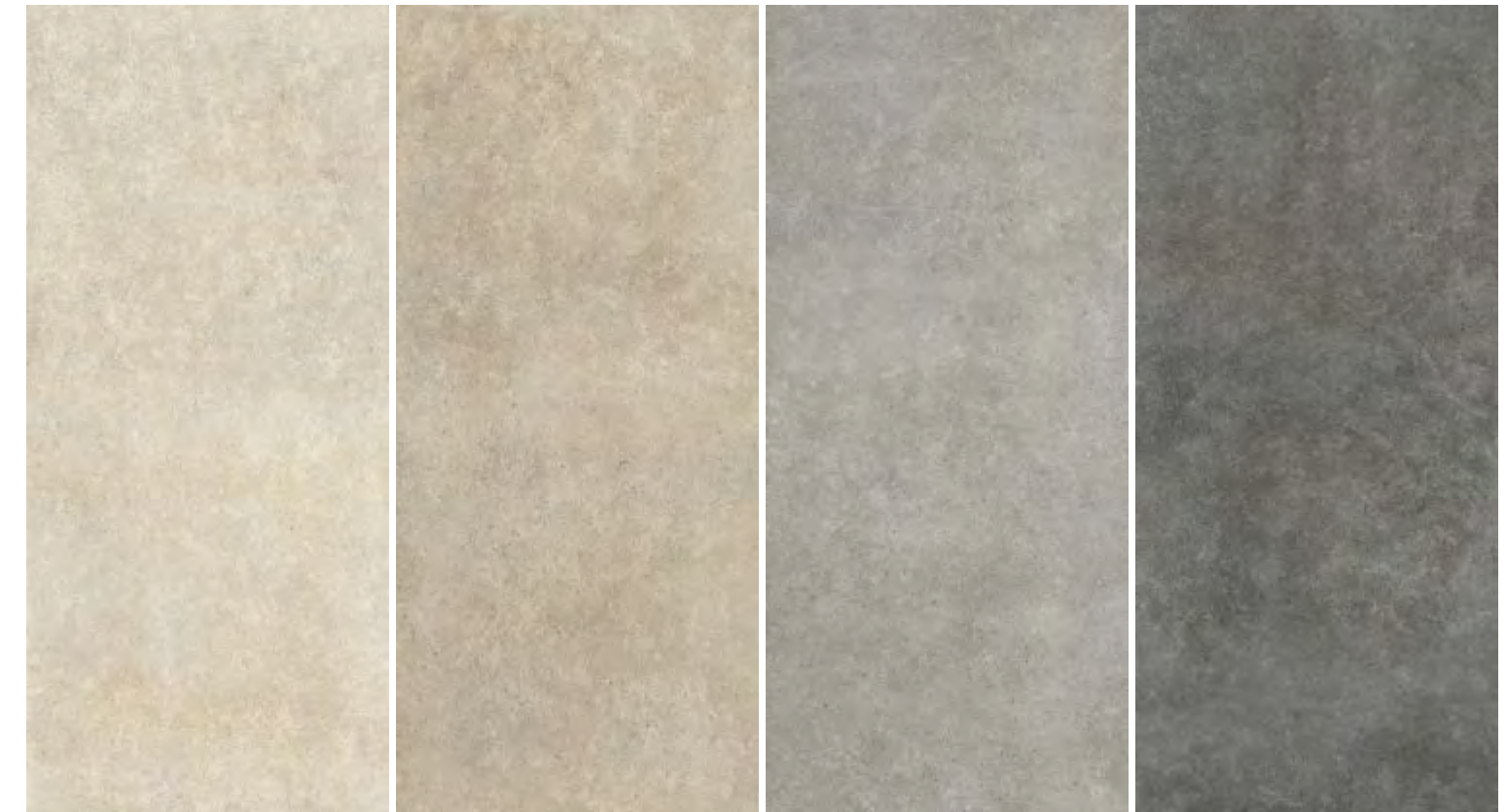

SNOWY

CREAM

CLOUD

CAVIAR

345 BACKGROUND\_STONE EFFECT



346 BACKGROUND\_STONE EFFECT



347 BACKGROUND\_STONE EFFECT



348 BACKGROUND\_STONE EFFECT



SNOWY LINE



349 BACKGROUND\_STONE EFFECT

CREAM / CREAM EMPAIRE 3D TEXTURE



350 BACKGROUND\_STONE EFFECT



351 BACKGROUND\_STONE EFFECT







# background

354 BACKGROUND\_STONE EFFECT

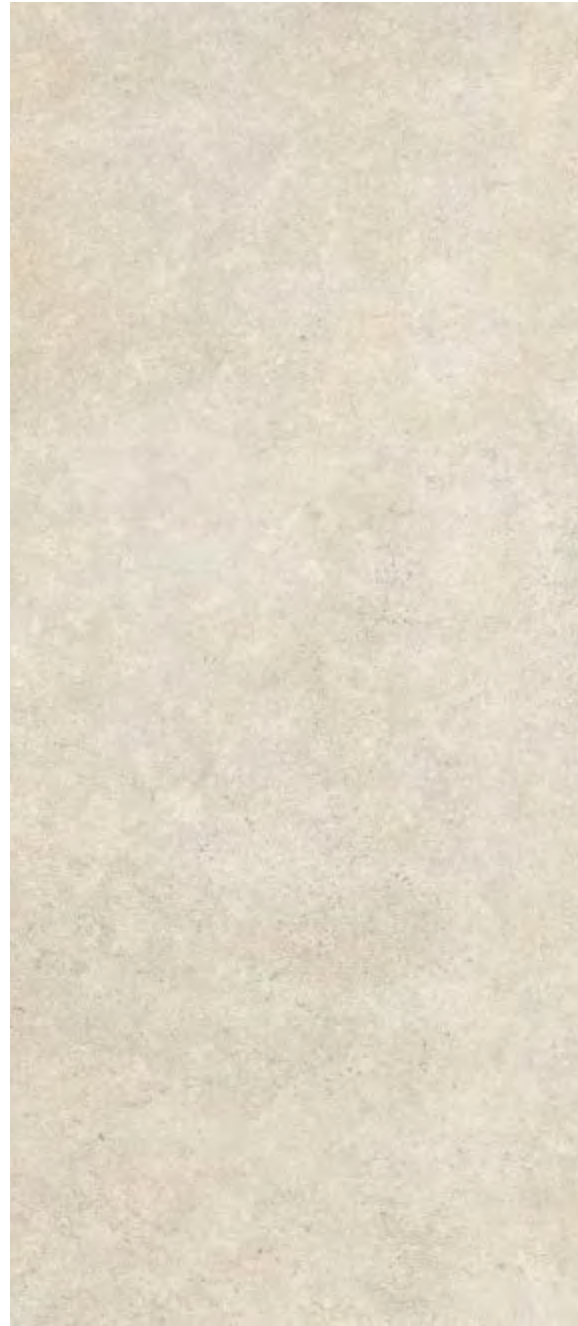

## SIZES & SURFACES



**120x278\***  
47,24"x109,45"



**120x120**  
47,24"x47,24"



**60x120**  
23,62"x47,24"



**80x80**  
31,50"x31,50"

**Real Matt**  
Rettificato | Rectified |  
Rectifié | Rektifiziert

**6,5 mm**

**120x278** . 47,24"x109,45"  
**BAG005**

**120x120** . 47,24"x47,24"  
**BAG013**

**8,5 mm**

**60x120** . 23,62"x47,24"  
**BAG025**

**80x80** . 31,50"x31,50"  
**BAG033**

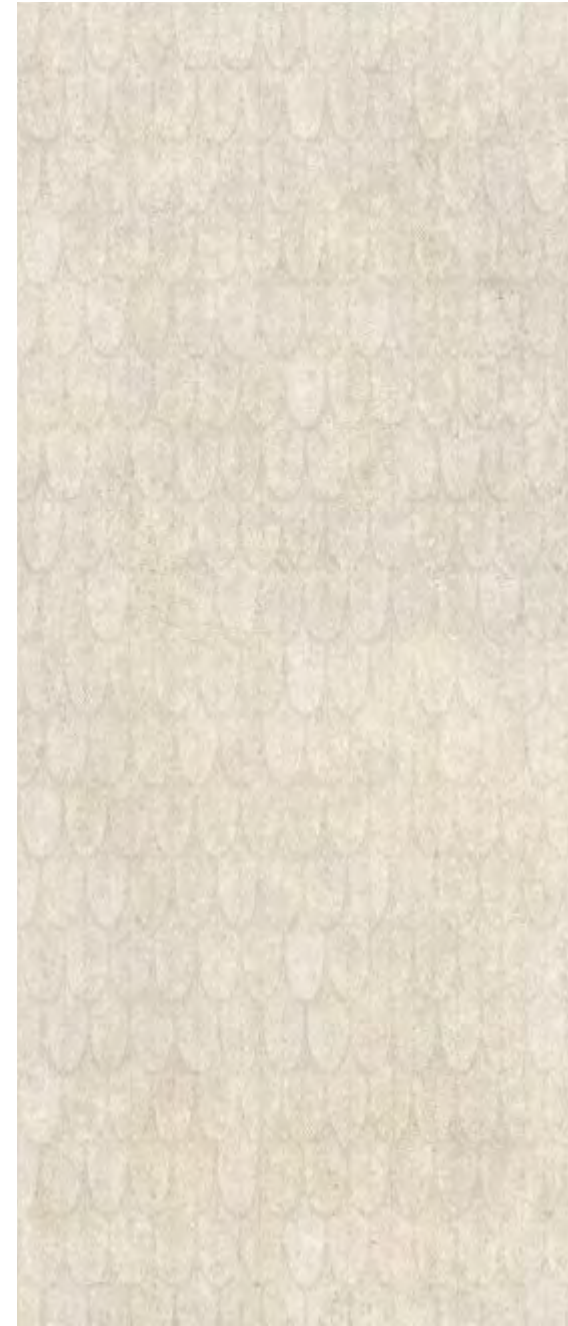

355 BACKGROUND\_STONE EFFECT

## SNOWY

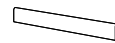

**6,5 mm**  
**8x120** . 3,15"x47,24"  
battiscopa  
**BAG037**



**6,5 mm**  
**33x120x5** . 12,99"x47,24"x1,97"  
gradino lineare LL  
**BAG041**



**6,5 mm**  
**33x120x5** . 12,99"x47,24"x1,97"  
gradino angolare LL  
**BAG045**

**8,5 mm**  
**8x80** . 3,15"x31,50"  
battiscopa  
**BAG049**

**8,5 mm**  
**40x80x5** . 15,75"x31,50"x1,97"  
gradino lineare M  
**BAG053**

**8,5 mm**  
**40x80x5** . 15,75"x31,50"x1,97"  
gradino angolare M  
**BAG057**

**Suggested grout**  
130 . Jasmine



## SNOWY EMPAIRE

**6,5 mm**  
**120x278** . 47,24"x109,45"  
decoro  
**BAG095**

## SNOWY LINE

**8,5 mm**  
**60x120** . 23,62"x47,24"  
decoro  
**BAG029**





# background

356 BACKGROUND\_STONE EFFECT



## SIZES & SURFACES



**120x278\***  
47,24"x109,45"



**120x120**  
47,24"x47,24"



**60x120**  
23,62"x47,24"



**80x80**  
31,50"x31,50"

**Real Matt**  
Rettificato | Rectified |  
Rectifié | Rektifiziert

### 6,5 mm

**120x278** . 47,24"x109,45"  
**BAG006**

**120x120** . 47,24"x47,24"  
**BAG014**

### 8,5 mm

**60x120** . 23,62"x47,24"  
**BAG026**

**80x80** . 31,50"x31,50"  
**BAG034**

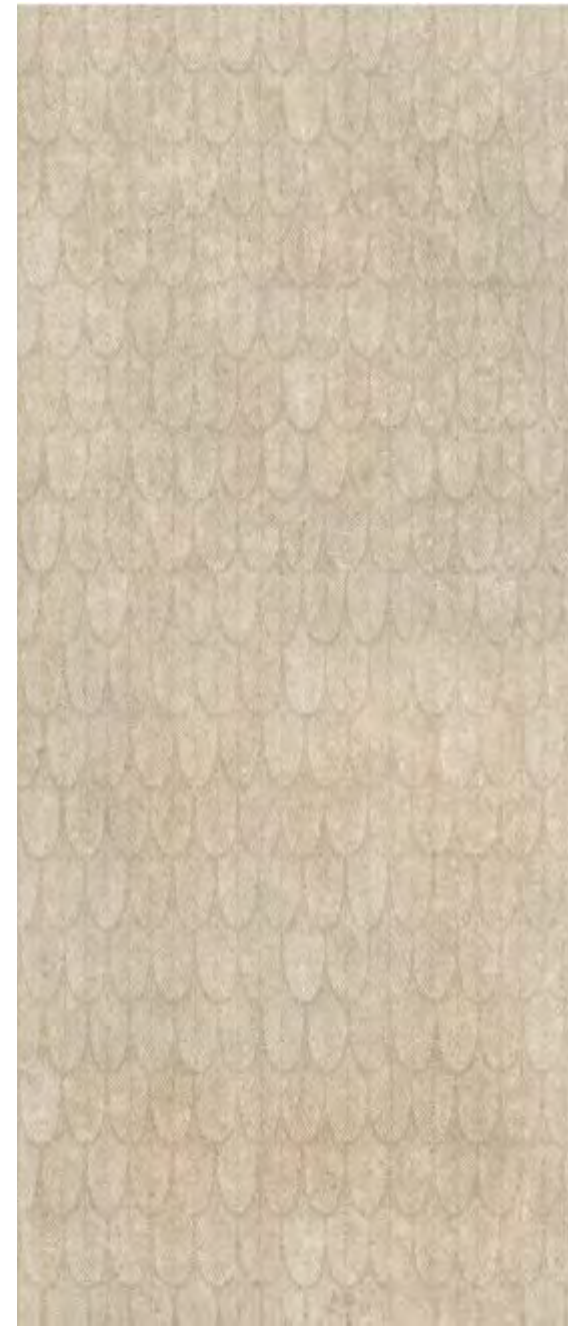

357 BACKGROUND\_STONE EFFECT

## CREAM

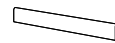

**6,5 mm**  
**8x120** . 3,15"x47,24"  
battiscopa  
**BAG038**



**6,5 mm**  
**33x120x5** . 12,99"x47,24"x1,97"  
gradino lineare LL  
**BAG042**



**6,5 mm**  
**33x120x5** . 12,99"x47,24"x1,97"  
gradino angolare LL  
**BAG046**

**8,5 mm**  
**8x80** . 3,15"x31,50"  
battiscopa  
**BAG050**

**8,5 mm**  
**40x80x5** . 15,75"x31,50"x1,97"  
gradino lineare M  
**BAG054**

**8,5 mm**  
**40x80x5** . 15,75"x31,50"x1,97"  
gradino angolare M  
**BAG058**

**Suggested grout**  
188 . Biscuit



## CREAM EMPAIRE

**6,5 mm**  
**120x278** . 47,24"x109,45"  
decoro  
**BAG096**

## CREAM LINE

**8,5 mm**  
**60x120** . 23,62"x47,24"  
decoro  
**BAG030**

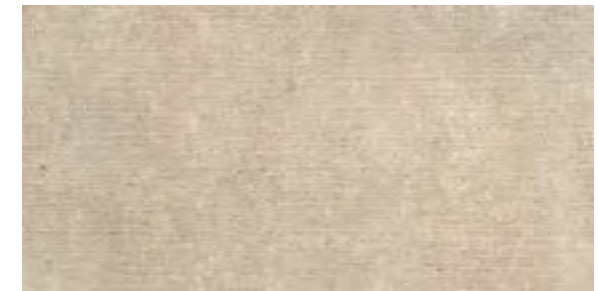



# background

358 BACKGROUND\_STONE EFFECT



## SIZES & SURFACES



**120x278\***  
47,24"x109,45"



**120x120**  
47,24"x47,24"



**60x120**  
23,62"x47,24"



**80x80**  
31,50"x31,50"

**Real Matt**  
Rettificato | Rectified |  
Rectifié | Rektifiziert

**6,5 mm**

**120x278** . 47,24"x109,45"  
**BAG007**

**120x120** . 47,24"x47,24"  
**BAG015**

**8,5 mm**

**60x120** . 23,62"x47,24"  
**BAG027**

**80x80** . 31,50"x31,50"  
**BAG035**



## CLOUD EMPAIRE

**6,5 mm**  
**120x278** . 47,24"x109,45"  
decoro  
**BAG097**

359 BACKGROUND\_STONE EFFECT

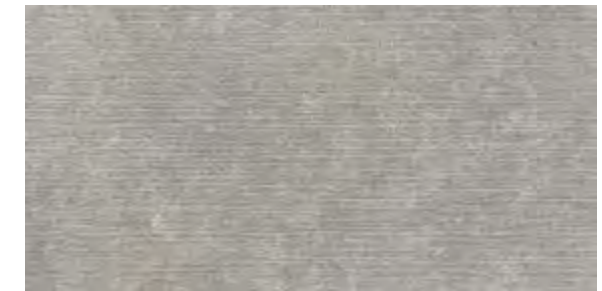

## CLOUD LINE

**8,5 mm**  
**60x120** . 23,62"x47,24"  
decoro  
**BAG031**

## CLOUD

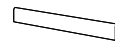

**6,5 mm**  
**8x120** . 3,15"x47,24"  
battiscopa  
**BAG039**



**6,5 mm**  
**33x120x5** . 12,99"x47,24"x1,97"  
gradino lineare LL  
**BAG043**



**6,5 mm**  
**33x120x5** . 12,99"x47,24"x1,97"  
gradino angolare LL  
**BAG047**

**8,5 mm**  
**8x80** . 3,15"x31,50"  
battiscopa  
**BAG051**

**8,5 mm**  
**40x80x5** . 15,75"x31,50"x1,97"  
gradino lineare M  
**BAG055**

**8,5 mm**  
**40x80x5** . 15,75"x31,50"x1,97"  
gradino angolare M  
**BAG059**

**Suggested grout**  
112 . Medium Grey





# background

360 BACKGROUND\_STONE EFFECT

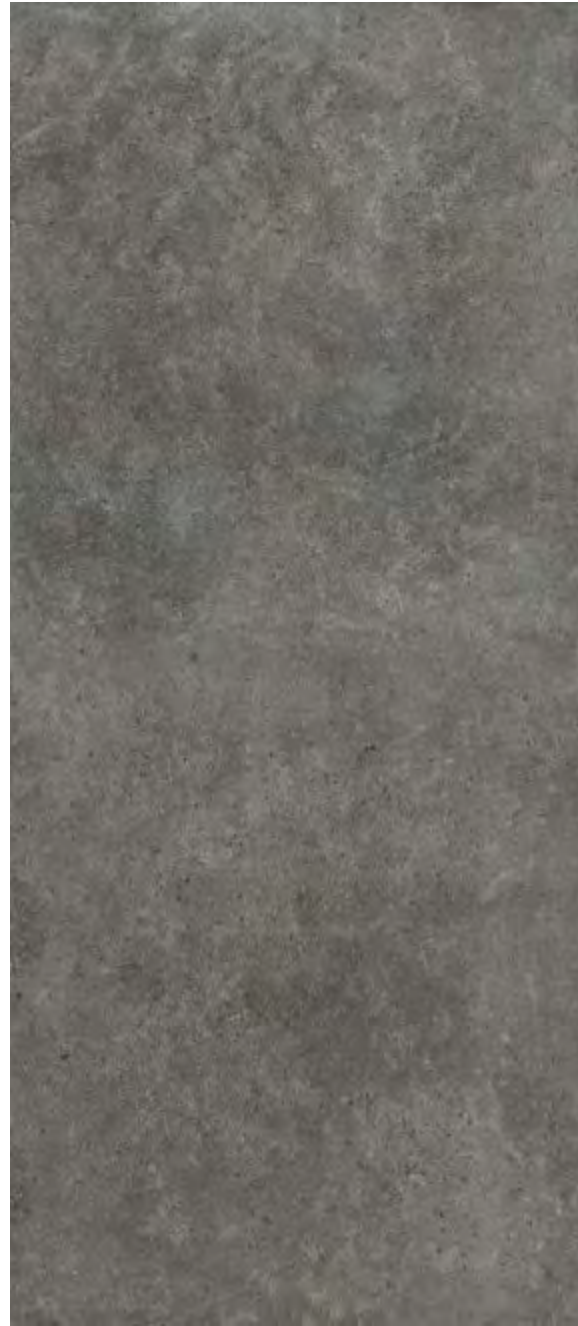

## SIZES & SURFACES



**120x278\***  
47,24"x109,45"



**120x120**  
47,24"x47,24"



**60x120**  
23,62"x47,24"



**80x80**  
31,50"x31,50"

**Real Matt**  
Rettificato | Rectified |  
Rectifié | Rektifiziert

**6,5 mm**

**120x278** . 47,24"x109,45"  
**BAG008**

**120x120** . 47,24"x47,24"  
**BAG016**

**8,5 mm**

**60x120** . 23,62"x47,24"  
**BAG028**

**80x80** . 31,50"x31,50"  
**BAG036**



## CAVIAR EMPAIRE

**6,5 mm**  
**120x278** . 47,24"x109,45"  
decoro  
**BAG098**

361 BACKGROUND\_STONE EFFECT

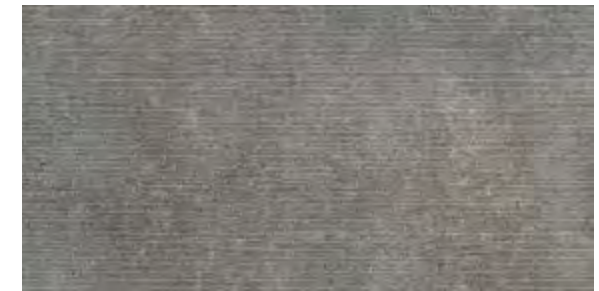

## CAVIAR LINE

**8,5 mm**  
**60x120** . 23,62"x47,24"  
decoro  
**BAG032**

## CAVIAR

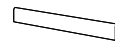

**6,5 mm**  
**8x120** . 3,15"x47,24"  
battiscopa  
**BAG040**



**6,5 mm**  
**33x120x5** . 12,99"x47,24"x1,97"  
gradino lineare LL  
**BAG044**



**6,5 mm**  
**33x120x5** . 12,99"x47,24"x1,97"  
gradino angolare LL  
**BAG048**

**8,5 mm**  
**8x80** . 3,15"x31,50"  
battiscopa  
**BAG052**

**8,5 mm**  
**40x80x5** . 15,75"x31,50"x1,97"  
gradino lineare M  
**BAG056**

**8,5 mm**  
**40x80x5** . 15,75"x31,50"x1,97"  
gradino angolare M  
**BAG060**

**Suggested grout**  
119 . London Grey







# royal travertino



Lastre / piastrelle di ceramica in gres porcellanato - Gruppo Bla UGL  
Porcelain stoneware slabs / tiles - Gruppe Bla UGL  
Dalles / carreaux en céramique en grès cérame - Group Bla UGL  
Keramikplatten / keramikfliesen aus Feinsteinzeug - Gruppe Bla UGL

## THICKNESS



6,5 mm 8,5 mm  
SELF LEVELING

## SURFACES

**Real Matt**  
Rettificato | Rectified |  
Rectifié | Rektifiziert

## TECH INFO



BS EN 16165\_C >  
Dry & Wet rubber 4S: ≥ 36  
AS 4586 > P3  
UNE-ENV 12633 > Class 2



120x278\*  
47,24"x109,45"



120x120  
47,24"x47,24"



60x120  
23,62"x47,24"



80x80  
31,50"x31,50"

\* Lastre realizzate attraverso impasti colorati con colori standard | Slabs produced using coloured body mix available in standard shades

## COLORS



EBUR VEIN



NAVONA VEIN

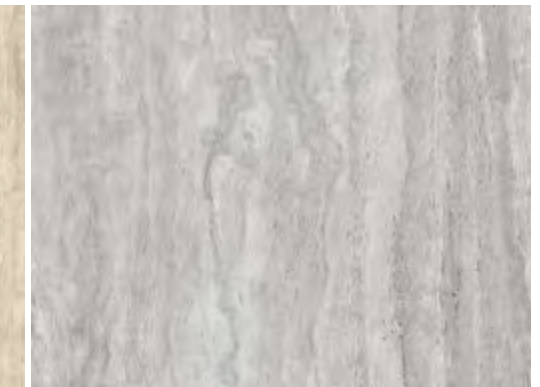

GRISEO VEIN

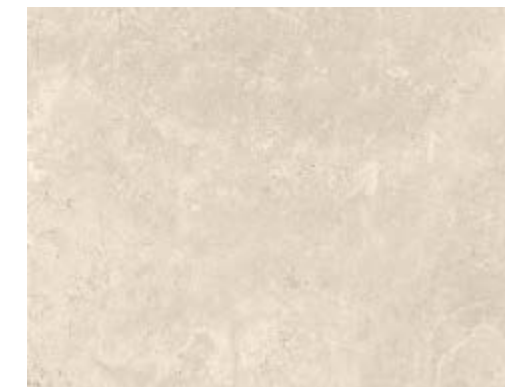

EBUR CROSS

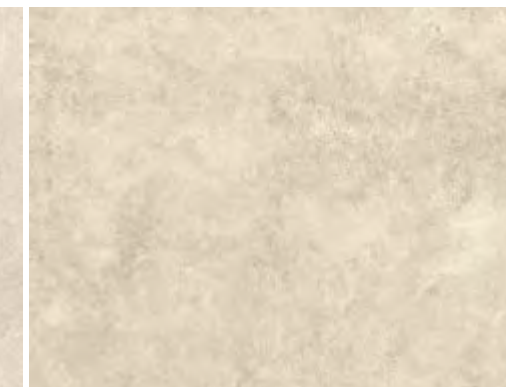

NAVONA CROSS

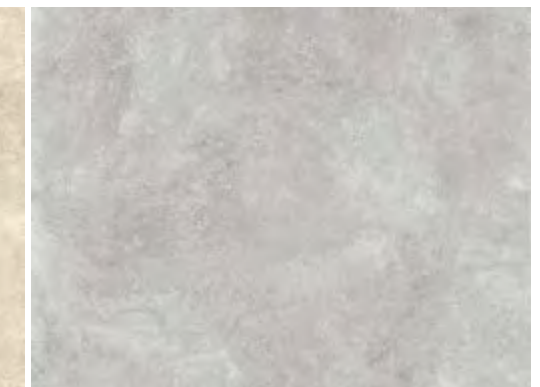

GRISEO CROSS





EBUR VEIN / EBUR CROSS / EBUR WAVY VEIN



EBUR VEIN





NAVONA VEIN / NAVONA CROSS



367 ROYAL TRAVERTINO - STONE EFFECT

NAVONA VEIN / NAVONA CROSS



368 ROYAL TRAVERTINO\_STONE EFFECT



369 ROYAL TRAVERTINO\_STONE EFFECT



# royal travertino

370 ROYAL TRAVERTINO\_STONE EFFECT



## SIZES & SURFACES



**120x278\***  
47,24"x109,45"



**60x120**  
23,62"x47,24"

**Real Matt**  
Rettificato | Rectified |  
Rectifié | Rektifiziert

**6,5 mm**

**120x278** . 47,24"x109,45"  
**ROT016**

**8,5 mm**

**60x120** . 23,62"x47,24"  
**ROT019**

## EBUR VEIN

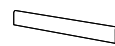

**6,5 mm**  
**8x120** . 3,15"x47,24"  
battiscopa  
**ROT028**

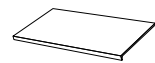

**6,5 mm**  
**33x120x5** . 12,99"x47,24"x1,97"  
gradino lineare LL  
**ROT031**

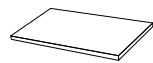

**6,5 mm**  
**33x120x5** . 12,99"x47,24"x1,97"  
gradino angolare LL  
**ROT034**

**8,5 mm**  
**8x120** . 3,15"x47,24"  
battiscopa  
**ROT055**

**8,5 mm**  
**33x120x5** . 12,99"x47,24"x1,97"  
gradino lineare M  
**ROT058**

**8,5 mm**  
**33x120x5** . 12,99"x47,24"x1,97"  
gradino angolare M  
**ROT061**

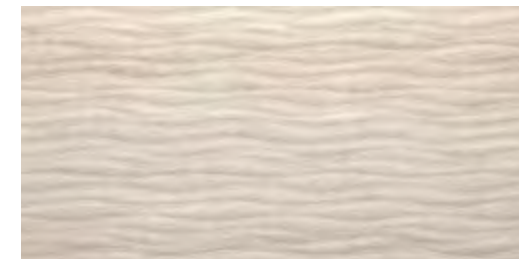

## EBUR WAVY VEIN

**8,5 mm**  
**60x120** . 23,62"x47,24"  
decoro  
**ROT022**

**Suggested grout**  
130 . Jasmine

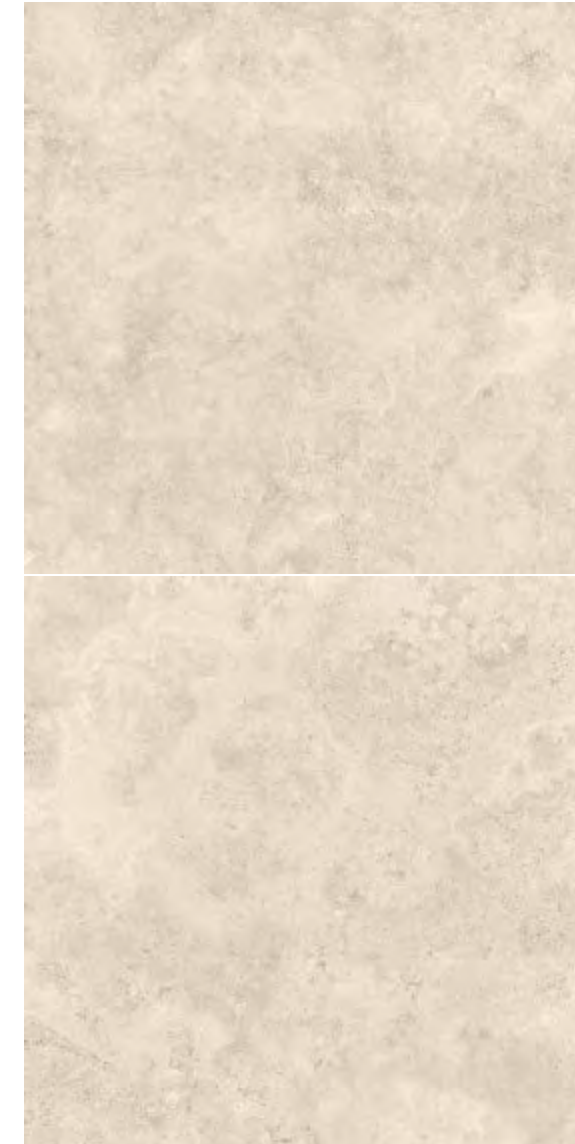

## SIZES & SURFACES



**120x120**  
47,24"x47,24"



**80x80**  
31,50"x31,50"

**Real Matt**  
Rettificato | Rectified |  
Rectifié | Rektifiziert

**6,5 mm**

**120x120** . 47,24"x47,24"  
**ROT004**

**8,5 mm**

**80x80** . 31,50"x31,50"  
**ROT025**

## EBUR CROSS

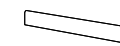

**6,5 mm**  
**8x120** . 3,15"x47,24"  
battiscopa  
**ROT037**

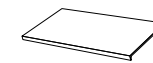

**6,5 mm**  
**33x120x5** . 12,99"x47,24"x1,97"  
gradino lineare LL  
**ROT040**

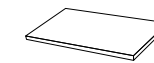

**6,5 mm**  
**33x120x5** . 12,99"x47,24"x1,97"  
gradino angolare LL  
**ROT043**

**8,5 mm**  
**8x80** . 3,15"x31,50"  
battiscopa  
**ROT046**

**8,5 mm**  
**40x80x5** . 15,75"x31,50"x1,97"  
gradino lineare M  
**ROT049**

**8,5 mm**  
**40x80x5** . 15,75"x31,50"x1,97"  
gradino angolare M  
**ROT052**

**Suggested grout**  
130 . Jasmine



371 ROYAL TRAVERTINO\_STONE EFFECT



# royal travertino

372 ROYAL TRAVERTINO\_STONE EFFECT



## SIZES & SURFACES



**120x278\***  
47,24"x109,45"



**60x120**  
23,62"x47,24"

**Real Matt**  
Rettificato | Rectified |  
Rectifié | Rektifiziert

**6,5 mm**

**120x278** . 47,24"x109,45"  
**ROT017**

**8,5 mm**

**60x120** . 23,62"x47,24"  
**ROT020**

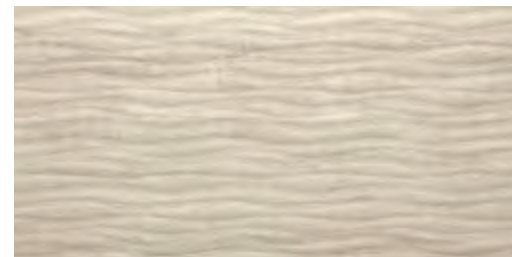

## NAVONA WAVY VEIN

**8,5 mm**  
**60x120** . 23,62"x47,24"  
decoro  
**ROT023**

**Suggested grout**  
137 . Caribbean



## SIZES & SURFACES

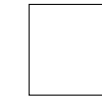

**120x120**  
47,24"x47,24"



**80x80**  
31,50"x31,50"

**Real Matt**  
Rettificato | Rectified |  
Rectifié | Rektifiziert

**6,5 mm**



**120x120** . 47,24"x47,24"  
**ROT005**

**8,5 mm**

**80x80** . 31,50"x31,50"  
**ROT026**



## NAVONA CROSS

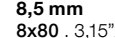
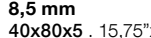
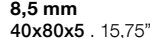

		
<b>6,5 mm</b> <b>8x120</b> . 3,15"x47,24" battiscopa <b>ROT038</b>	<b>6,5 mm</b> <b>33x120x5</b> . 12,99"x47,24"x1,97" gradino lineare LL <b>ROT041</b>	<b>6,5 mm</b> <b>33x120x5</b> . 12,99"x47,24"x1,97" gradino angolare LL <b>ROT044</b>

		
<b>8,5 mm</b> <b>8x80</b> . 3,15"x31,50" battiscopa <b>ROT047</b>	<b>8,5 mm</b> <b>40x80x5</b> . 15,75"x31,50"x1,97" gradino lineare M <b>ROT050</b>	<b>8,5 mm</b> <b>40x80x5</b> . 15,75"x31,50"x1,97" gradino angolare M <b>ROT053</b>

**Suggested grout**  
137 . Caribbean

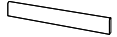

## NAVONA VEIN

		
<b>6,5 mm</b> <b>8x120</b> . 3,15"x47,24" battiscopa <b>ROT029</b>	<b>6,5 mm</b> <b>33x120x5</b> . 12,99"x47,24"x1,97" gradino lineare LL <b>ROT032</b>	<b>6,5 mm</b> <b>33x120x5</b> . 12,99"x47,24"x1,97" gradino angolare LL <b>ROT035</b>
<b>8,5 mm</b> <b>8x120</b> . 3,15"x47,24" battiscopa <b>ROT056</b>	<b>8,5 mm</b> <b>33x120x5</b> . 12,99"x47,24"x1,97" gradino lineare M <b>ROT059</b>	<b>8,5 mm</b> <b>33x120x5</b> . 12,99"x47,24"x1,97" gradino angolare M <b>ROT062</b>

373 ROYAL TRAVERTINO\_STONE EFFECT



# royal travertino

374 ROYAL TRAVERTINO\_STONE EFFECT



## SIZES & SURFACES



**120x278\***  
47,24"x109,45"



**60x120**  
23,62"x47,24"

**Real Matt**  
Rettificato | Rectified |  
Rectifié | Rektifiziert

**6,5 mm**

**120x278** . 47,24"x109,45"  
**ROT018**

**8,5 mm**

**60x120** . 23,62"x47,24"  
**ROT021**

## GRISEO VEIN

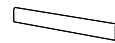

**6,5 mm**  
**8x120** . 3,15"x47,24"  
battiscopa  
**ROT030**

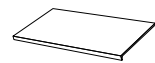

**6,5 mm**  
**33x120x5** . 12,99"x47,24"x1,97"  
gradino lineare LL  
**ROT033**

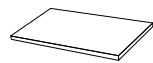

**6,5 mm**  
**33x120x5** . 12,99"x47,24"x1,97"  
gradino angolare LL  
**ROT036**

**8,5 mm**  
**8x120** . 3,15"x47,24"  
battiscopa  
**ROT057**

**8,5 mm**  
**33x120x5** . 12,99"x47,24"x1,97"  
gradino lineare M  
**ROT060**

**8,5 mm**  
**33x120x5** . 12,99"x47,24"x1,97"  
gradino angolare M  
**ROT063**

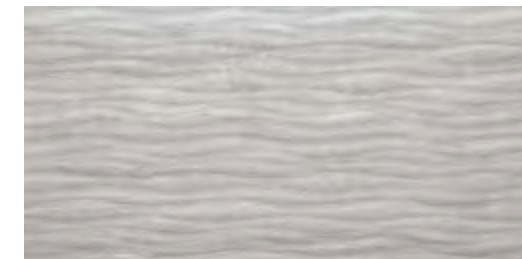

## GRISEO WAVY VEIN

**8,5 mm**  
**60x120** . 23,62"x47,24"  
decoro  
**ROT024**

**Suggested grout**  
110 . Manhattan 2000



## GRISEO CROSS

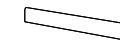

**6,5 mm**  
**8x120** . 3,15"x47,24"  
battiscopa  
**ROT039**

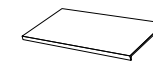

**6,5 mm**  
**33x120x5** . 12,99"x47,24"x1,97"  
gradino lineare LL  
**ROT042**

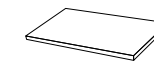

**6,5 mm**  
**33x120x5** . 12,99"x47,24"x1,97"  
gradino angolare LL  
**ROT045**

**8,5 mm**  
**8x80** . 3,15"x31,50"  
battiscopa  
**ROT048**

**8,5 mm**  
**40x80x5** . 15,75"x31,50"x1,97"  
gradino lineare M  
**ROT051**

**8,5 mm**  
**40x80x5** . 15,75"x31,50"x1,97"  
gradino angolare M  
**ROT054**

**Suggested grout**  
110 . Manhattan 2000



## SIZES & SURFACES



**120x120**  
47,24"x47,24"



**80x80**  
31,50"x31,50"

**Real Matt**  
Rettificato | Rectified |  
Rectifié | Rektifiziert

**6,5 mm**

**120x120** . 47,24"x47,24"  
**ROT006**

**8,5 mm**

**80x80** . 31,50"x31,50"  
**ROT027**

375 ROYAL TRAVERTINO\_STONE EFFECT



# upper

Lastre / piastrelle di ceramica in gres porcellanato - Gruppo Bla UGL  
 Porcelain stoneware slabs / tiles - Gruppe Bla UGL  
 Dalles / carreaux en céramique en grès cérame - Group Bla UGL  
 Keramikplatten / keramikfliesen aus Feinsteinzeug - Gruppe Bla UGL



376 UPPER\_STONE EFFECT

## THICKNESS



6,5 mm 8,5 mm  
 SELF LEVELING

**2.OUT** 2 cm

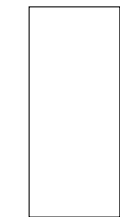

120x278\*  
 47,24"x109,45"



120x120  
 47,24"x47,24"



60x120  
 23,62"x47,24"



100x100  
 39,37"x39,37"

## SURFACES

**Natural / Grip**  
 Rettificato | Rectified |  
 Rectifi | Rektifiziert

## TECH INFO



BS EN 16165\_C >  
 Dry & Wet rubber 4S: ≥ 36  
 AS 4586 > P3  
 UNE-ENV 12633 > Class 2

Outdoor



BS EN 16165\_C >  
 Dry & Wet rubber 4S: ≥ 36  
 AS 4586 > P3  
 UNE-ENV 12633 > Class 2

\* Lastre realizzate attraverso impasti colorati con colori standard | Slabs produced using coloured body mix available in standard shades

## COLORS

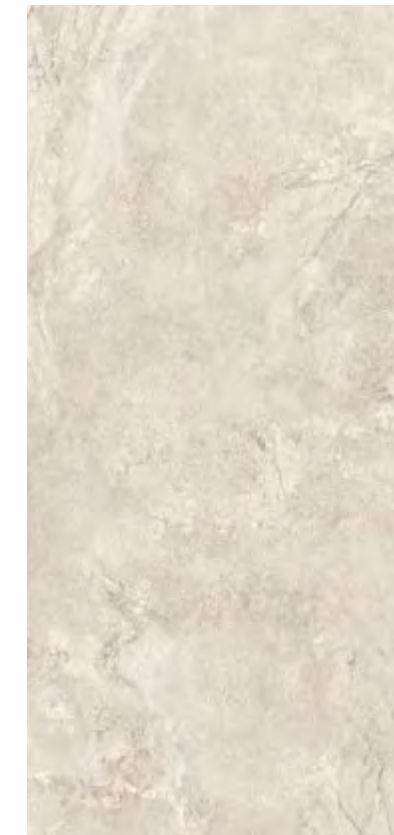

BUTTER



FOG



DOVE GREY

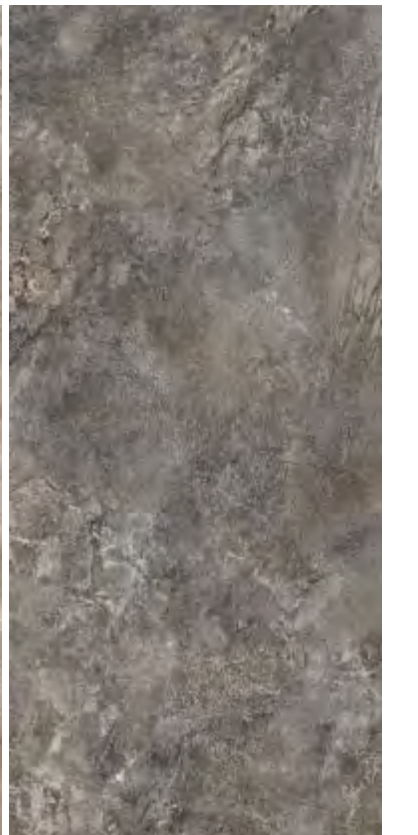

ELEPHANT GREY

377 UPPER\_STONE EFFECT



378 UPPER STONE EFFECT



379 UPPER STONE EFFECT





380 UPPER STONE EFFECT

DOVE GREY / DOVE GREY STICK



381 UPPER STONE EFFECT

F06



382 UPPER\_STONE EFFECT



383 UPPER\_STONE EFFECT



# upper

384 UPPER\_STONE EFFECT



## SIZES & SURFACES



**120x278\***  
47,24"x109,45"



**120x120**  
47,24"x47,24"



**60x120**  
23,62"x47,24"

**Natural**  
Rettificato | Rectified |  
Rectifié | Rektifiziert

**6,5 mm**

**120x278** . 47,24"x109,45"  
**UPP013**

**120x120** . 47,24"x47,24"  
**UPP005**

**8,5 mm**

**60x120** . 23,62"x47,24"  
**UPP092**

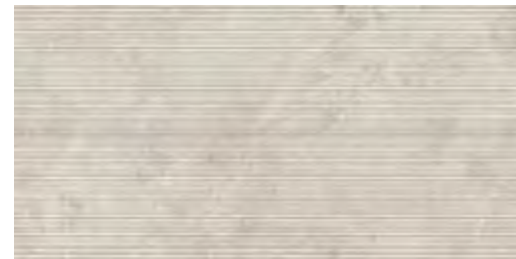

## BUTTER STICK

**8,5 mm**  
**60x120** . 23,62"x47,24"  
decoro  
**UPP096**

**Suggested grout**  
137 . Caribbean



## BUTTER

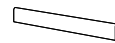

**6,5 mm**  
**8x120** . 3,15"x47,24"  
battiscopa  
**UPP017**

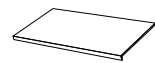

**6,5 mm**  
**33x120x5** . 12,99"x47,24"x1,97"  
gradino lineare LL  
**UPP021**



**6,5 mm**  
**33x120x5** . 12,99"x47,24"x1,97"  
gradino angolare LL  
**UPP025**

**8,5 mm**  
**8x80** . 3,15"x31,50"  
battiscopa  
**UPP053**

**8,5 mm**  
**40x80x5** . 15,75"x31,50"x1,97"  
gradino lineare M  
**UPP057**

**8,5 mm**  
**40x80x5** . 15,75"x31,50"x1,97"  
gradino angolare M  
**UPP061**



## SIZES & SURFACES



**120x278\***  
47,24"x109,45"



**120x120**  
47,24"x47,24"



**60x120**  
23,62"x47,24"



**100x100**  
39,37"x39,37"

**Natural**  
Rettificato | Rectified |  
Rectifié | Rektifiziert

**6,5 mm**

**120x278** . 47,24"x109,45"  
**UPP015**

**120x120** . 47,24"x47,24"  
**UPP007**

**8,5 mm**

**60x120** . 23,62"x47,24"  
**UPP094**

**Grip**  
Rettificato | Rectified |  
Rectifié | Rektifiziert

**2.OUT 2 cm**

**Outdoor**  
**100x100** . 39,37"x39,37"  
**UPP104**



## FOG STICK

**8,5 mm**  
**60x120** . 23,62"x47,24"  
decoro  
**UPP098**

**Suggested grout**  
110 . Manhattan 2000



## FOG



**6,5 mm**  
**8x120** . 3,15"x47,24"  
battiscopa  
**UPP019**

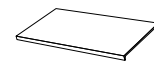

**6,5 mm**  
**33x120x5** . 12,99"x47,24"x1,97"  
gradino lineare LL  
**UPP023**

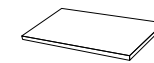

**6,5 mm**  
**33x120x5** . 12,99"x47,24"x1,97"  
gradino angolare LL  
**UPP027**

**8,5 mm**  
**8x80** . 3,15"x31,50"  
battiscopa  
**UPP055**

**8,5 mm**  
**40x80x5** . 15,75"x31,50"x1,97"  
gradino lineare M  
**UPP059**

**8,5 mm**  
**40x80x5** . 15,75"x31,50"x1,97"  
gradino angolare M  
**UPP063**

385 UPPER\_STONE EFFECT



# upper

386 UPPER\_STONE EFFECT



## SIZES & SURFACES



**120x278\***  
47,24"x109,45"



**120x120**  
47,24"x47,24"



**60x120**  
23,62"x47,24"

**Natural**  
Rettificato | Rectified |  
Rectifié | Rektifiziert

**6,5 mm**

**120x278** . 47,24"x109,45"  
**UPP014**

**120x120** . 47,24"x47,24"  
**UPP006**

**8,5 mm**

**60x120** . 23,62"x47,24"  
**UPP093**



## DOVE GREY STICK

**8,5 mm**  
**60x120** . 23,62"x47,24"  
decoro  
**UPP097**

**Suggested grout**  
133 . Sand



## SIZES & SURFACES



**120x278\***  
47,24"x109,45"



**120x120**  
47,24"x47,24"



**60x120**  
23,62"x47,24"

**Natural**  
Rettificato | Rectified |  
Rectifié | Rektifiziert

**6,5 mm**

**120x278** . 47,24"x109,45"  
**UPP016**

**120x120** . 47,24"x47,24"  
**UPP008**

**8,5 mm**

**60x120** . 23,62"x47,24"  
**UPP095**



## ELEPHANT GREY STICK

**8,5 mm**  
**60x120** . 23,62"x47,24"  
decoro  
**UPP099**

**Suggested grout**  
120 . Black



## DOVE GREY

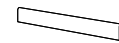

**6,5 mm**  
**8x120** . 3,15"x47,24"  
battiscopa  
**UPP018**



**6,5 mm**  
**33x120x5** . 12,99"x47,24"x1,97"  
gradino lineare LL  
**UPP022**



**6,5 mm**  
**33x120x5** . 12,99"x47,24"x1,97"  
gradino angolare LL  
**UPP026**

**8,5 mm**  
**8x80** . 3,15"x31,50"  
battiscopa  
**UPP054**

**8,5 mm**  
**40x80x5** . 15,75"x31,50"x1,97"  
gradino lineare M  
**UPP058**

**8,5 mm**  
**40x80x5** . 15,75"x31,50"x1,97"  
gradino angolare M  
**UPP062**

## ELEPHANT GREY

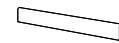

**6,5 mm**  
**8x120** . 3,15"x47,24"  
battiscopa  
**UPP020**

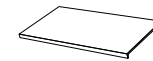

**6,5 mm**  
**33x120x5** . 12,99"x47,24"x1,97"  
gradino lineare LL  
**UPP024**

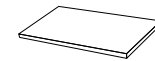

**6,5 mm**  
**33x120x5** . 12,99"x47,24"x1,97"  
gradino angolare LL  
**UPP028**

**8,5 mm**  
**8x80** . 3,15"x31,50"  
battiscopa  
**UPP056**

**8,5 mm**  
**40x80x5** . 15,75"x31,50"x1,97"  
gradino lineare M  
**UPP060**

**8,5 mm**  
**40x80x5** . 15,75"x31,50"x1,97"  
gradino angolare M  
**UPP064**

387 UPPER\_STONE EFFECT



# pezzi speciali

Special trims | Pièces spéciales | Formteile

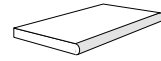

**2 cm**  
**40x100x2** . 15,75"x39,37"x0,78"  
gradone toro lineare  
**UPP105** Fog

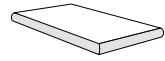

**2 cm**  
**40x100x2** . 15,75"x39,37"x0,78"  
gradone toro angolare dx  
**UPP106** Fog

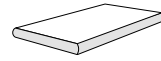

**2 cm**  
**40x100x2** . 15,75"x39,37"x0,78"  
gradone toro angolare sx  
**UPP107** Fog

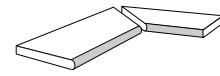

**2 cm**  
**40x100x2** . 15,75"x39,37"x0,78"  
comp. gradone toro ang. interno  
**UPP108** Fog

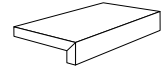

**2 cm**  
**40x100x5** . 15,75"x39,37"x1,97"  
elemento L lineare  
**UPP109** Fog

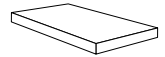

**2 cm**  
**40x100x5** . 15,75"x39,37"x1,97"  
elemento L angolare dx  
**UPP110** Fog

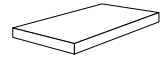

**2 cm**  
**40x100x5** . 15,75"x39,37"x1,97"  
elemento L angolare sx  
**UPP111** Fog

## 2.0UT





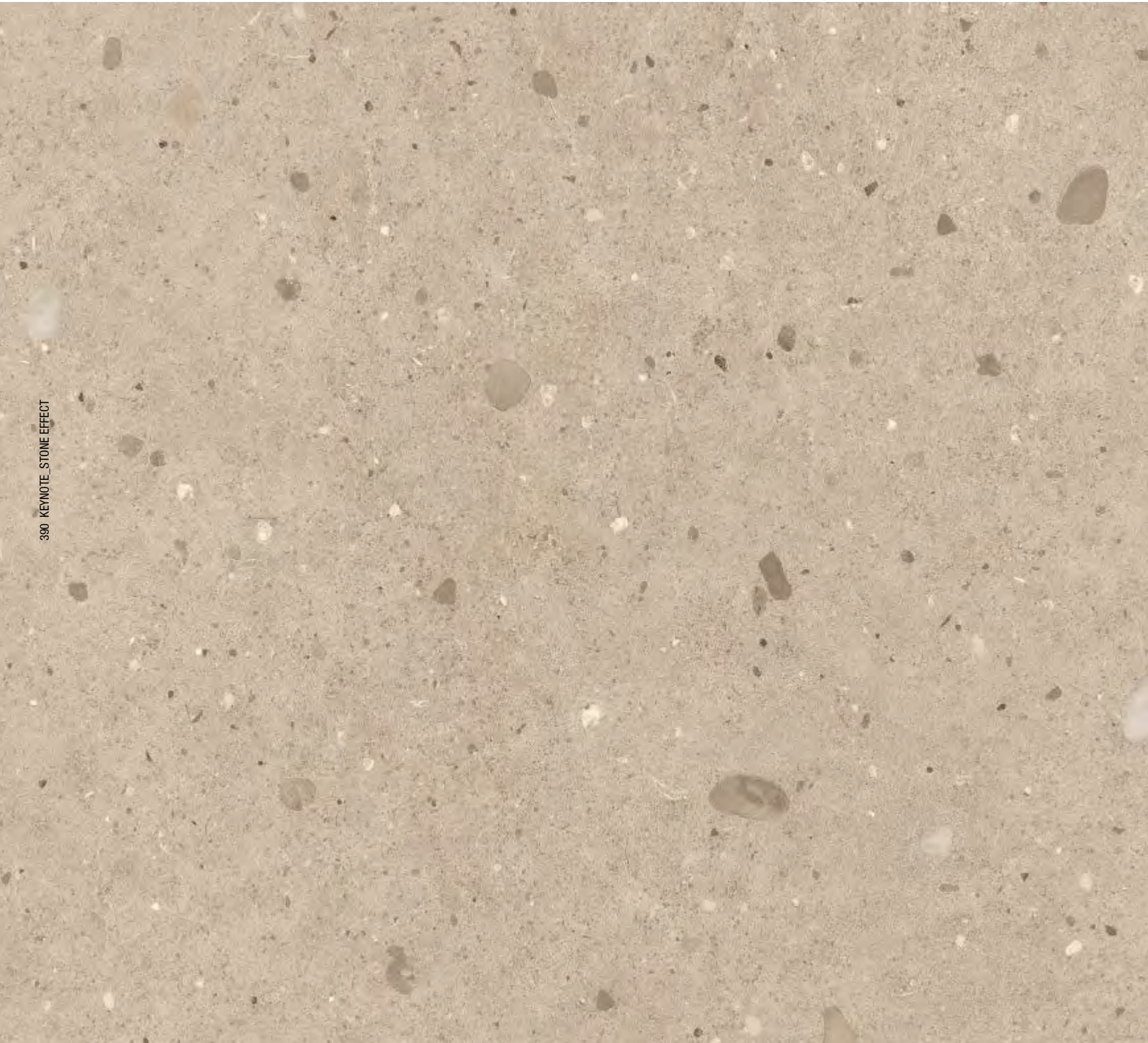

# keynote

Lastre / piastrelle di ceramica in gres porcellanato - Gruppo Bla UGL  
Porcelain stoneware slabs / tiles - Gruppe Bla UGL  
Dalles / carreaux en céramique en grès cérame - Group Bla UGL  
Keramikplatten / keramikfliesen aus Feinsteinzeug - Gruppe Bla UGL

### THICKNESS



6,5 mm 8,5 mm  
SELF LEVELING 10 mm\*

### SURFACES

Natural  
Rettificato | Rectified |  
Rectifié | Rektifiziert

### TECH INFO



BS EN 16165\_C >  
Dry & Wet rubber 4S: ≥ 36  
AS 4586 > P3  
UNE-ENV 12633 > Class 2



120x278\*  
47,24"x109,45"



120x120  
47,24"x47,24"



60x120  
23,62"x47,24"



80x80  
31,50"x31,50"



40x80  
15,75"x31,50"

\* Lastre realizzate attraverso impasti colorati con colori standard | Slabs produced using coloured body mix available in standard shades  
• Disponibile fino ad esaurimento scorte | Available while stocks last | Disponible jusqu'à épuisement des stocks | Verfügbar solange der Vorrat reicht

### COLORS



PEARL

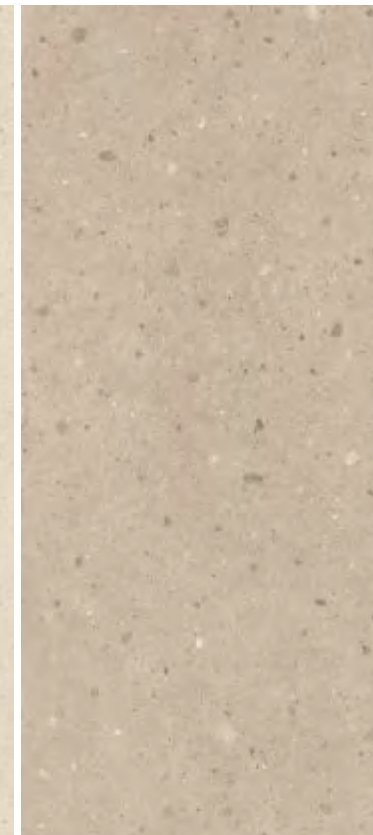

AMBER

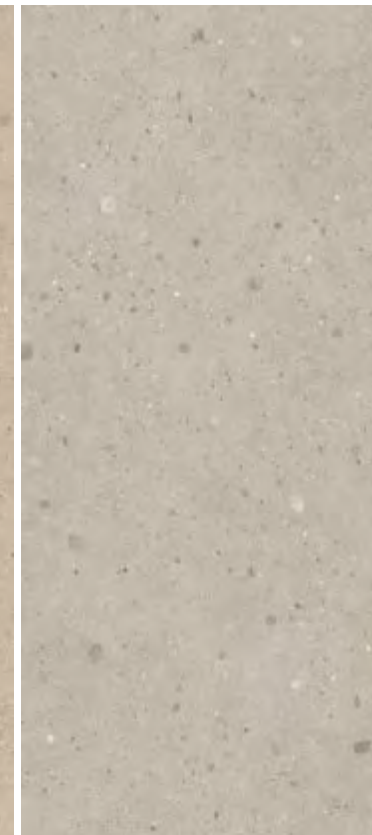

ARCTIC



COOL GREY



392 KEYNOTE\_STONE EFFECT



393 KEYNOTE\_STONE EFFECT





394 KEYNOTE\_STONE EFFECT

AMBER

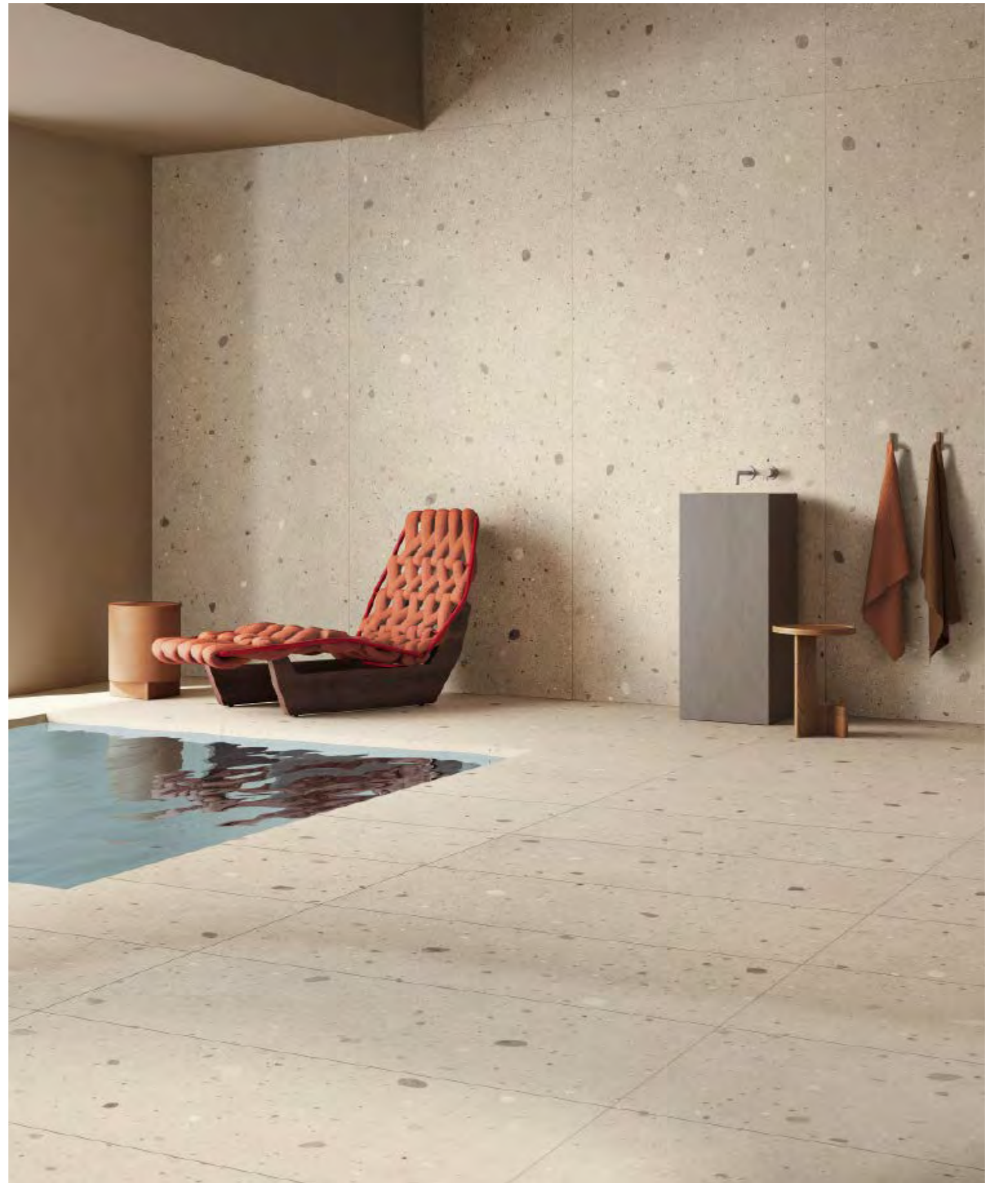

395 KEYNOTE\_STONE EFFECT

PEARL



# keynote

396 KEYNOTE\_STONE EFFECT



## SIZES & SURFACES



**120x278\***  
47,24"x109,45"



**120x120**  
47,24"x47,24"



**60x120**  
23,62"x47,24"



**80x80**  
31,50"x31,50"



**40x80**  
15,75"x31,50"

**Natural**  
Rettificato | Rectified |  
Rectifié | Rektifiziert

### 6,5 mm

**120x278** . 47,24"x109,45"  
**KEY019**

**120x120** . 47,24"x47,24"  
**KEY007**

### 8,5 mm

**60x120** . 23,62"x47,24"  
**KEY153**

**80x80** . 31,50"x31,50"  
**KEY165**

**40x80** . 15,75"x31,50"  
**KEY177**

**Natural**  
Rettificato | Rectified |  
Rectifié | Rektifiziert

### 10 mm\*

**60x120** . 23,62"x47,24"  
**KEY025**

**80x80** . 31,50"x31,50"  
**KEY037**

**40x80** . 15,75"x31,50"  
**KEY049**

## PEARL

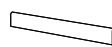

**6,5 mm KEY055**  
**8x120** . 3,15"x47,24"  
battiscopa



**6,5 mm KEY061**  
**33x120x5** . 12,99"x47,24"x1,97"  
gradino lineare LL



**6,5 mm KEY067**  
**33x120x5** . 12,99"x47,24"x1,97"  
gradino angolare LL

**8,5 mm KEY073A**  
**10 mm KEY073\***  
**8x80** . 3,15"x31,50"  
battiscopa

**8,5 mm KEY079A**  
**10 mm KEY079\***  
**40x80x5** . 15,75"x31,50"x1,97"  
gradino lineare M

**8,5 mm KEY085A**  
**10 mm KEY085\***  
**40x80x5** . 15,75"x31,50"x1,97"  
gradino angolare M

**6,5 mm**  
**5x30** . 1,97"x11,81"  
listello  
**KEY097**

- Disponibile fino ad esaurimento scorte | Available while stocks last |  
Disponibile jusqu'à épuisement des stocks | Verfügbar solange der  
Vorrat reicht

**Suggested grout**  
137 . Caribbean



397 KEYNOTE\_STONE EFFECT

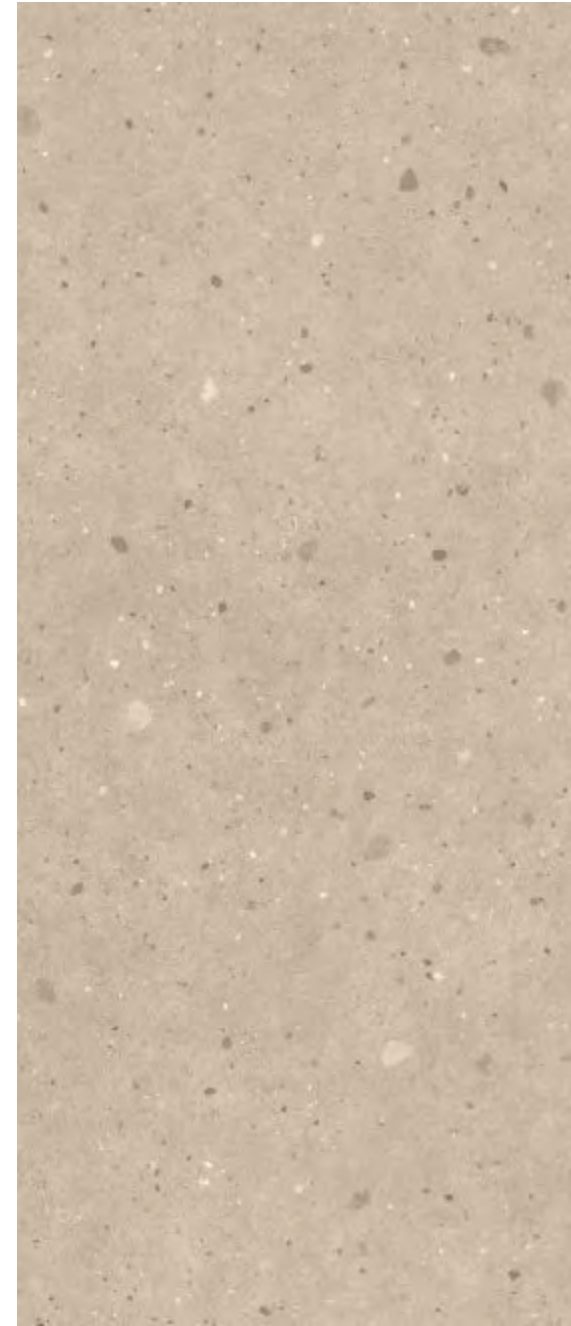

## SIZES & SURFACES



**120x278\***  
47,24"x109,45"



**120x120**  
47,24"x47,24"



**60x120**  
23,62"x47,24"



**80x80**  
31,50"x31,50"



**40x80**  
15,75"x31,50"

**Natural**  
Rettificato | Rectified |  
Rectifié | Rektifiziert

### 6,5 mm

**120x278** . 47,24"x109,45"  
**KEY020**

**120x120** . 47,24"x47,24"  
**KEY008**

### 8,5 mm

**60x120** . 23,62"x47,24"  
**KEY154**

**80x80** . 31,50"x31,50"  
**KEY166**

**40x80** . 15,75"x31,50"  
**KEY178**

**Natural**  
Rettificato | Rectified |  
Rectifié | Rektifiziert

### 10 mm\*

**60x120** . 23,62"x47,24"  
**KEY026**

**80x80** . 31,50"x31,50"  
**KEY038**

**40x80** . 15,75"x31,50"  
**KEY050**

## AMBER

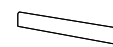

**6,5 mm KEY056**  
**8x120** . 3,15"x47,24"  
battiscopa

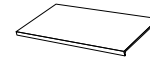

**6,5 mm KEY062**  
**33x120x5** . 12,99"x47,24"x1,97"  
gradino lineare LL

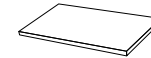

**6,5 mm KEY068**  
**33x120x5** . 12,99"x47,24"x1,97"  
gradino angolare LL

**8,5 mm KEY074A**  
**10 mm KEY074\***  
**8x80** . 3,15"x31,50"  
battiscopa

**8,5 mm KEY080A**  
**10 mm KEY080\***  
**40x80x5** . 15,75"x31,50"x1,97"  
gradino lineare M

**8,5 mm KEY086A**  
**10 mm KEY086\***  
**40x80x5** . 15,75"x31,50"x1,97"  
gradino angolare M

**6,5 mm**  
**5x30** . 1,97"x11,81"  
listello  
**KEY098**

- Disponibile fino ad esaurimento scorte | Available while stocks last |  
Disponibile jusqu'à épuisement des stocks | Verfügbar solange der  
Vorrat reicht

**Suggested grout**  
133 . Sand





# keynote

398 KEYNOTE\_STONE EFFECT



## SIZES & SURFACES



**120x278\***  
47,24"x109,45"



**120x120**  
47,24"x47,24"



**60x120**  
23,62"x47,24"



**80x80**  
31,50"x31,50"



**40x80**  
15,75"x31,50"

**Natural**  
Rettificato | Rectified |  
Rectifié | Rektifiziert

### 6,5 mm

**120x278** . 47,24"x109,45"  
**KEY022**

**120x120** . 47,24"x47,24"  
**KEY010**

### 8,5 mm

**60x120** . 23,62"x47,24"  
**KEY156**

**80x80** . 31,50"x31,50"  
**KEY168**

**40x80** . 15,75"x31,50"  
**KEY180**

**Natural**  
Rettificato | Rectified |  
Rectifié | Rektifiziert

### 10 mm\*

**60x120** . 23,62"x47,24"  
**KEY028**

**80x80** . 31,50"x31,50"  
**KEY040**

**40x80** . 15,75"x31,50"  
**KEY052**

## ARCTIC

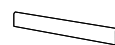

**6,5 mm KEY058**  
**8x120** . 3,15"x47,24"  
battiscopa



**6,5 mm KEY064**  
**33x120x5** . 12,99"x47,24"x1,97"  
gradino lineare LL



**6,5 mm KEY070**  
**33x120x5** . 12,99"x47,24"x1,97"  
gradino angolare LL

**8,5 mm KEY076A**  
**10 mm KEY076\***  
**8x80** . 3,15"x31,50"  
battiscopa

**8,5 mm KEY082A**  
**10 mm KEY082\***  
**40x80x5** . 15,75"x31,50"x1,97"  
gradino lineare M

**8,5 mm KEY088A**  
**10 mm KEY088\***  
**40x80x5** . 15,75"x31,50"x1,97"  
gradino angolare M

**6,5 mm**  
**5x30** . 1,97"x11,81"  
listello  
**KEY100**

- Disponibile fino ad esaurimento scorte | Available while stocks last |  
Disponibile jusqu'à épuisement des stocks | Verfügbar solange der  
Vorrat reicht

**Suggested grout**  
110 . Manhattan 2000

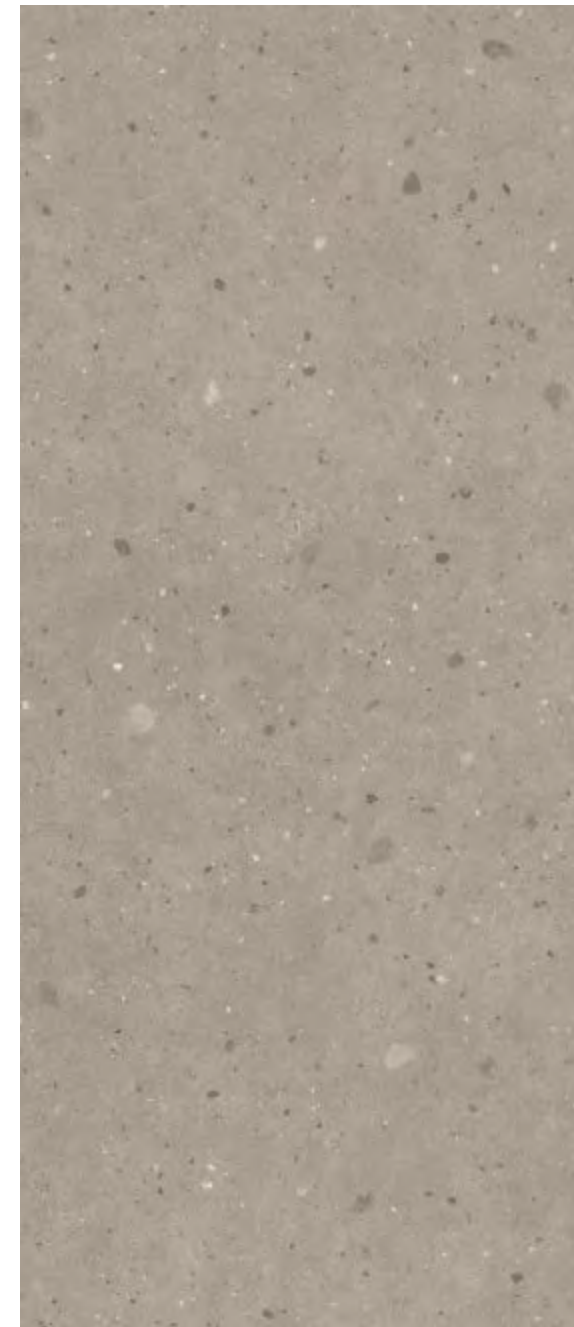

## SIZES & SURFACES



**120x278\***  
47,24"x109,45"



**120x120**  
47,24"x47,24"



**60x120**  
23,62"x47,24"



**80x80**  
31,50"x31,50"



**40x80**  
15,75"x31,50"

**Natural**  
Rettificato | Rectified |  
Rectifié | Rektifiziert

### 6,5 mm

**120x278** . 47,24"x109,45"  
**KEY023**

**120x120** . 47,24"x47,24"  
**KEY011**

### 8,5 mm

**60x120** . 23,62"x47,24"  
**KEY157**

**80x80** . 31,50"x31,50"  
**KEY169**

**40x80** . 15,75"x31,50"  
**KEY181**

**Natural**  
Rettificato | Rectified |  
Rectifié | Rektifiziert

### 10 mm\*

**60x120** . 23,62"x47,24"  
**KEY029**

**80x80** . 31,50"x31,50"  
**KEY041**

**40x80** . 15,75"x31,50"  
**KEY053**

## COOL GREY

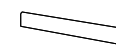

**6,5 mm KEY059**  
**8x120** . 3,15"x47,24"  
battiscopa

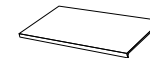

**6,5 mm KEY065**  
**33x120x5** . 12,99"x47,24"x1,97"  
gradino lineare LL

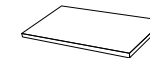

**6,5 mm KEY071**  
**33x120x5** . 12,99"x47,24"x1,97"  
gradino angolare LL

**8,5 mm KEY077A**  
**10 mm KEY077\***  
**8x80** . 3,15"x31,50"  
battiscopa

**8,5 mm KEY083A**  
**10 mm KEY083\***  
**40x80x5** . 15,75"x31,50"x1,97"  
gradino lineare M

**8,5 mm KEY089A**  
**10 mm KEY089\***  
**40x80x5** . 15,75"x31,50"x1,97"  
gradino angolare M

**6,5 mm**  
**5x30** . 1,97"x11,81"  
listello  
**KEY101**

- Disponibile fino ad esaurimento scorte | Available while stocks last |  
Disponibile jusqu'à épuisement des stocks | Verfügbar solange der  
Vorrat reicht

**Suggested grout**  
112 . Medium Grey



399 KEYNOTE\_STONE EFFECT



# keynote

LISTELLO

Il listello Keynote si abbinna armoniosamente con le superfici Res Art attraverso l'accostamento di colori differenti delle 2 collezioni secondo schemi di posa variabili. | The Keynote strips pair perfectly with Res Art, with the different colours from the two collections put together in a variety of arrangements to stunning effect. | Le listel Keynote se combine harmonieusement avec les surfaces Res Art grâce à la combinaison de différentes couleurs des 2 collections selon des schémas de pose variables. | Die Leiste Keynote passt durch die Kombination mit verschiedenen Farben der 2 Kollektionen entsprechend der variablen Verlegemuster auf harmonische Weise zu den Oberflächen Res Art.

Abbinamenti consigliati | Suggested mix and match | Assortiments conseillés | Empfohlene Kombinationen

RES ART COLORS

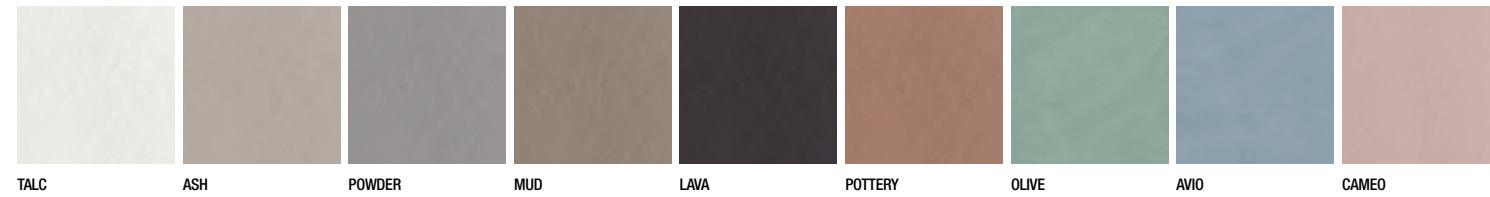

Alcuni suggerimenti di posa | Laying suggestions | Quelques conseils de pose | Einige Empfehlungen zur Verlegung

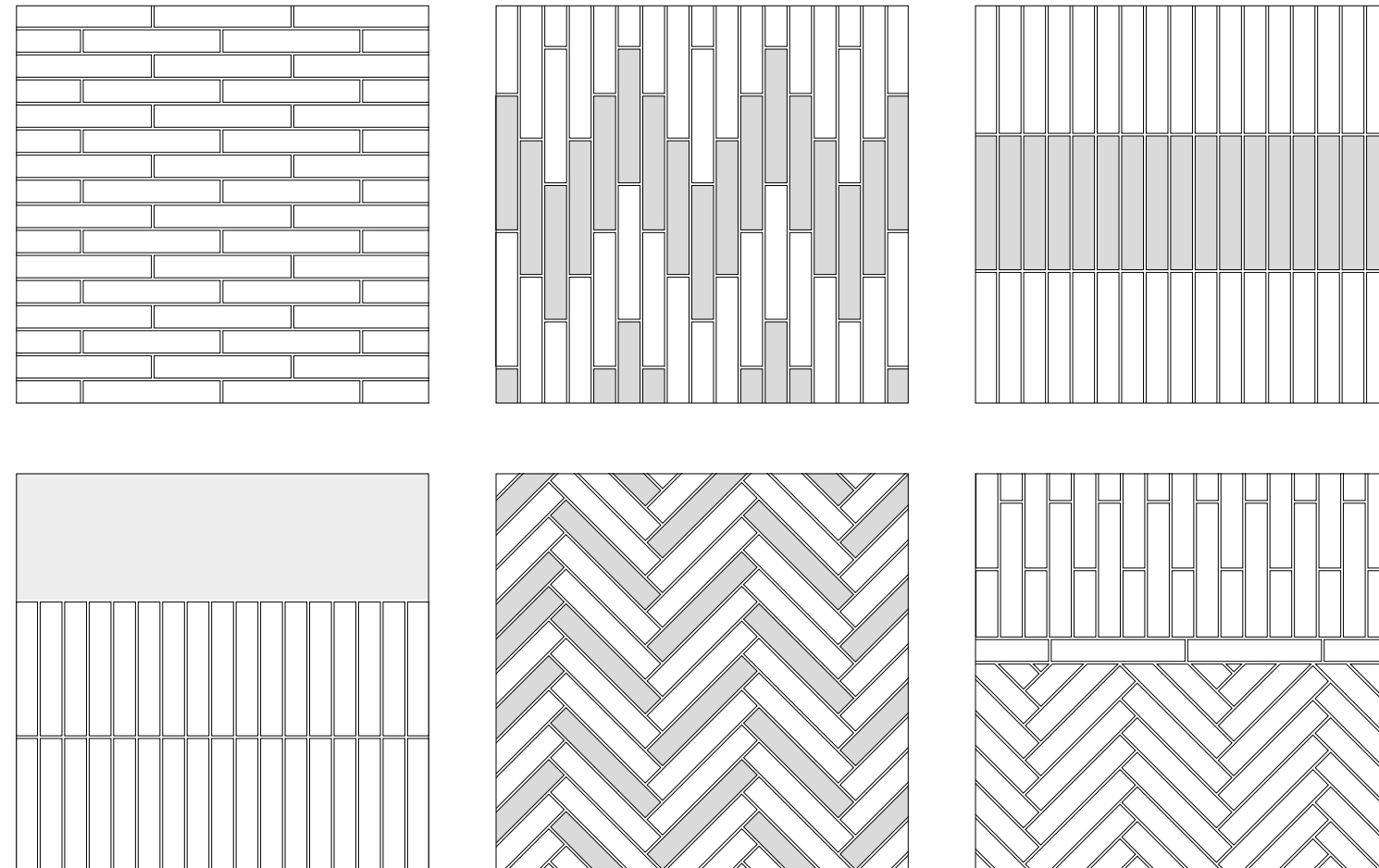



# reframe

Lastre / piastrelle di ceramica in gres porcellanato - Gruppo Bla UGL  
 Porcelain stoneware slabs / tiles - Gruppe Bla UGL  
 Dalles / carreaux en céramique en grès cérame - Group Bla UGL  
 Keramikplatten / keramikfliesen aus Feinsteinzeug - Gruppe Bla UGL

## THICKNESS



6,5 mm 8,5 mm  
 SELF LEVELING 10 mm•

## SURFACES

Natural  
 Rettificato | Rectified |  
 Rectifié | Rektifiziert

## TECH INFO



BS EN 16165\_C >  
 Dry & Wet rubber 4S: ≥ 36  
 AS 4586 > P3  
 UNE-ENV 12633 > Class 2



120x278\*  
 47,24"x109,45"



120x120  
 47,24"x47,24"



60x120  
 23,62"x47,24"



80x80  
 31,50"x31,50"



40x80  
 15,75"x31,50"

- \* Lastre realizzate attraverso impasti colorati con colori standard | Slabs produced using coloured body mix available in standard shades
- Disponibile fino ad esaurimento scorte | Available while stocks last | Disponible jusqu'à épuisement des stocks | Verfügbar solange der Vorrat reicht

## COLORS

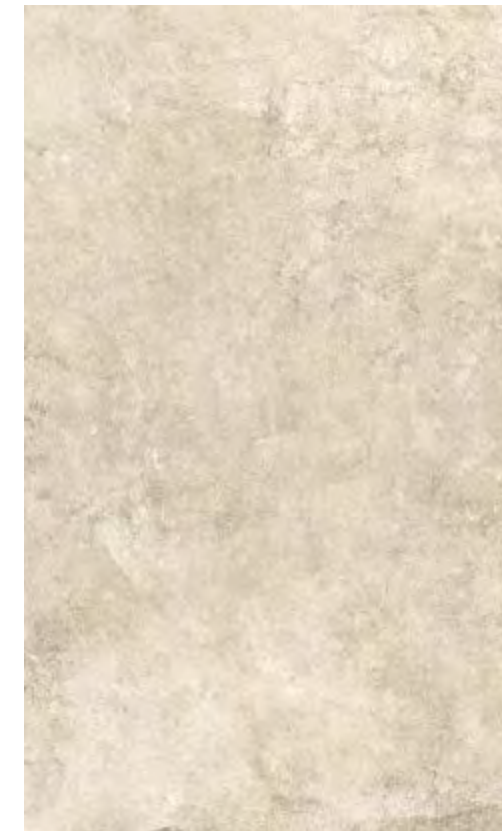

IVORY



TAUPE



GRAPHITE



404 REFRAME\_STONE EFFECT



405 REFRAME\_STONE EFFECT







# reframe

408 REFRAME\_STONE EFFECT



## SIZES & SURFACES



**120x278\***  
47,24"x109,45"



**120x120**  
47,24"x47,24"



**60x120**  
23,62"x47,24"



**80x80**  
31,50"x31,50"



**40x80**  
15,75"x31,50"

**Natural**  
Rettificato | Rectified |  
Rectifié | Rektifiziert

**6,5 mm**

**120x278** . 47,24"x109,45"  
**REF038**

**120x120** . 47,24"x47,24"  
**REF005**

**8,5 mm**

**60x120** . 23,62"x47,24"  
**REF089**

**80x80** . 31,50"x31,50"  
**REF092**

**40x80** . 15,75"x31,50"  
**REF095**

**Natural**  
Rettificato | Rectified |  
Rectifié | Rektifiziert

**10 mm\***

**60x120** . 23,62"x47,24"  
**REF008**

**80x80** . 31,50"x31,50"  
**REF011**

**40x80** . 15,75"x31,50"  
**REF014**

IVORY

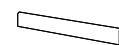

**6,5 mm REF017**  
**8x120** . 3,15"x47,24"  
battiscopa

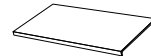

**6,5 mm REF020**  
**33x120x5** . 12,99"x47,24"x1,97"  
gradino lineare LL



**6,5 mm REF023**  
**33x120x5** . 12,99"x47,24"x1,97"  
gradino angolare LL

**8,5 mm REF026A**  
**10 mm REF026\***  
**8x80** . 3,15"x31,50"  
battiscopa

**8,5 mm REF029A**  
**10 mm REF029\***  
**40x80x5** . 15,75"x31,50"x1,97"  
gradino lineare M

**8,5 mm REF032A**  
**10 mm REF032\***  
**40x80x5** . 15,75"x31,50"x1,97"  
gradino angolare M

• Disponibile fino ad esaurimento scorte | Available while stocks last |  
Disponibile jusqu'à épuisement des stocks | Verfügbar solange der  
Vorrat reicht

**Suggested grout**  
130 . Jasmine



## SIZES & SURFACES



**120x278\***  
47,24"x109,45"



**120x120**  
47,24"x47,24"



**60x120**  
23,62"x47,24"



**80x80**  
31,50"x31,50"



**40x80**  
15,75"x31,50"

**Natural**  
Rettificato | Rectified |  
Rectifié | Rektifiziert

**6,5 mm**

**120x278** . 47,24"x109,45"  
**REF037**

**120x120** . 47,24"x47,24"  
**REF004**

**8,5 mm**

**60x120** . 23,62"x47,24"  
**REF090**

**80x80** . 31,50"x31,50"  
**REF093**

**40x80** . 15,75"x31,50"  
**REF096**

**Natural**  
Rettificato | Rectified |  
Rectifié | Rektifiziert

**10 mm\***

**60x120** . 23,62"x47,24"  
**REF007**

**80x80** . 31,50"x31,50"  
**REF010**

**40x80** . 15,75"x31,50"  
**REF013**

TAUPE

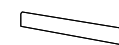

**6,5 mm REF016**  
**8x120** . 3,15"x47,24"  
battiscopa



**6,5 mm REF019**  
**33x120x5** . 12,99"x47,24"x1,97"  
gradino lineare LL

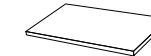

**6,5 mm REF022**  
**33x120x5** . 12,99"x47,24"x1,97"  
gradino angolare LL

**8,5 mm REF025A**  
**10 mm REF025\***  
**8x80** . 3,15"x31,50"  
battiscopa

**8,5 mm REF028A**  
**10 mm REF028\***  
**40x80x5** . 15,75"x31,50"x1,97"  
gradino lineare M

**8,5 mm REF031A**  
**10 mm REF031\***  
**40x80x5** . 15,75"x31,50"x1,97"  
gradino angolare M

• Disponibile fino ad esaurimento scorte | Available while stocks last |  
Disponibile jusqu'à épuisement des stocks | Verfügbar solange der  
Vorrat reicht

**Suggested grout**  
132 . Beige 2000



409 REFRAME\_STONE EFFECT



# reframe



410 REFRAME\_STONE EFFECT

## SIZES & SURFACES



**120x278\***  
47,24"x109,45"



**120x120**  
47,24"x47,24"



**60x120**  
23,62"x47,24"



**80x80**  
31,50"x31,50"



**40x80**  
15,75"x31,50"

**Natural**  
Rettificato | Rectified |  
Rectifié | Rektifiziert

### 6,5 mm

**120x278** . 47,24"x109,45"  
**REF039**

**120x120** . 47,24"x47,24"  
**REF006**

### 8,5 mm

**60x120** . 23,62"x47,24"  
**REF091**

**80x80** . 31,50"x31,50"  
**REF094**

**40x80** . 15,75"x31,50"  
**REF097**

**Natural**  
Rettificato | Rectified |  
Rectifié | Rektifiziert

### 10 mm\*

**60x120** . 23,62"x47,24"  
**REF009**

**80x80** . 31,50"x31,50"  
**REF012**

**40x80** . 15,75"x31,50"  
**REF015**

## GRAPHITE

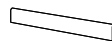

**6,5 mm REF018**  
**8x120** . 3,15"x47,24"  
battiscopa



**6,5 mm REF021**  
**33x120x5** . 12,99"x47,24"x1,97"  
gradino lineare LL



**6,5 mm REF024**  
**33x120x5** . 12,99"x47,24"x1,97"  
gradino angolare LL

**8,5 mm REF027A**  
**10 mm REF027\***  
**8x80** . 3,15"x31,50"  
battiscopa

**8,5 mm REF030A**  
**10 mm REF030\***  
**40x80x5** . 15,75"x31,50"x1,97"  
gradino lineare M

**8,5 mm REF033A**  
**10 mm REF033\***  
**40x80x5** . 15,75"x31,50"x1,97"  
gradino angolare M

- Disponibile fino ad esaurimento scorte | Available while stocks last |  
Disponibile jusqu'à épuisement des stocks | Verfügbar solange der  
Vorrat reicht

**Suggested grout**  
112 . Medium Grey



411 REFRAME\_STONE EFFECT

GRAPHITE







412 SHARDS\_STONE EFFECT

# shards











Lastre di ceramica in gres porcellanato - Gruppo Bla UGL  
 Porcelain stoneware slabs - Gruppe Bla UGL  
 Dalles en céramique en grès cérame - Group Bla UGL  
 Keramikplatten aus Feinsteinzeug - Gruppe Bla UGL

**THICKNESS**  
  
**6,5 mm**  
 SELF LEVELING

  
**120x120**  
 47,24"x47,24"

**SURFACES**  
**Glossy / Natural**  
 Rettificato | Rectified |  
 Rectifié | Rektifiziert

**TECH INFO**

Glossy							
Natural							

BS EN 16165\_C >  
 Dry & Wet rubber 4S: ≥ 36  
 AS 4586 > P3  
 UNE-ENV 12633 > Class 2

**COLORS**



LARGE WHITE

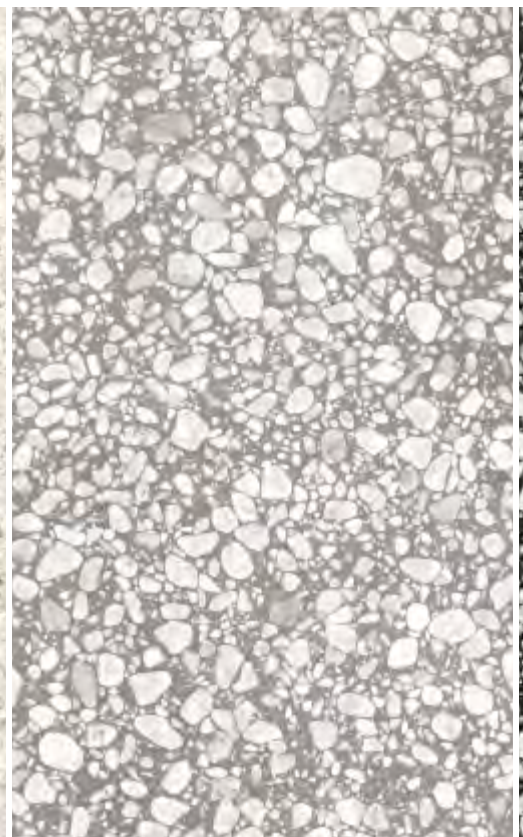

LARGE GREY

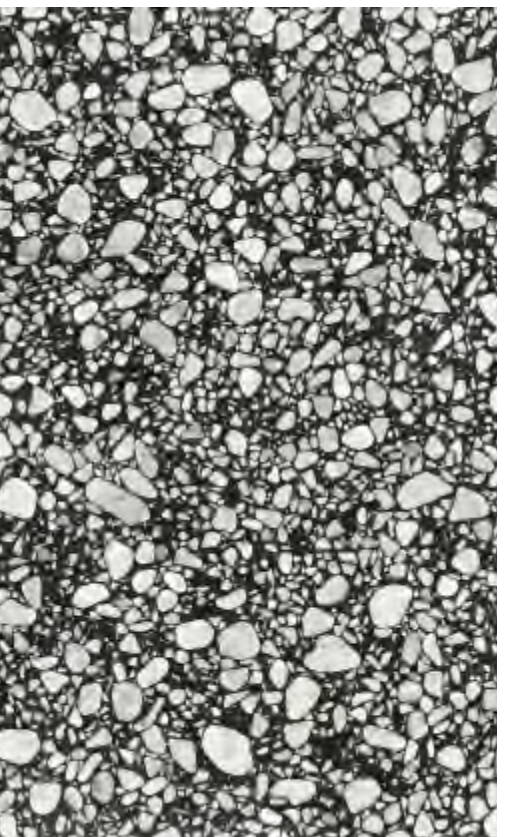

LARGE BLACK

413 SHARDS\_STONE EFFECT





LARGE GREY



LARGE WHITE







# shards

REGISTERED DESIGN



SIZES & SURFACES



120x120  
47,24"x47,24"

6,5 mm

**LARGE**

Glossy  
Rettificato | Rectified |  
Rectifié | Rektifiziert

120x120 . 47,24"x47,24"  
**SHA030**

Natural  
Rettificato | Rectified |  
Rectifié | Rektifiziert

120x120 . 47,24"x47,24"  
**SHA078**

WHITE

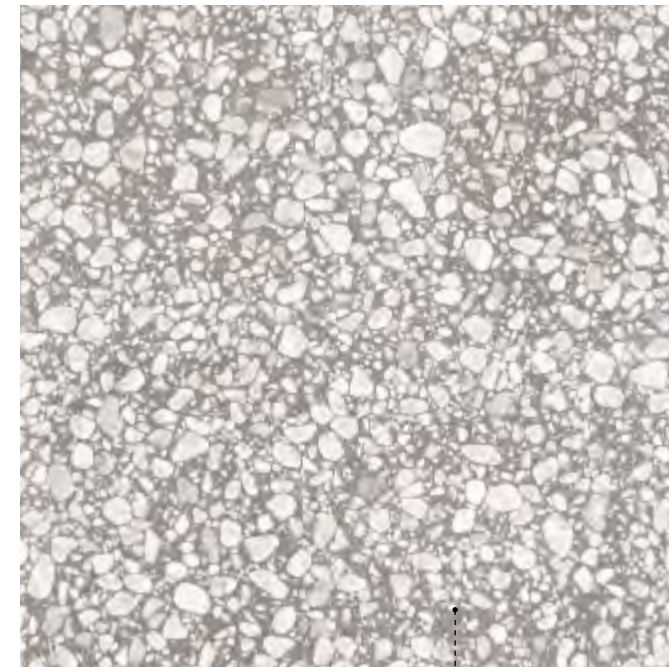
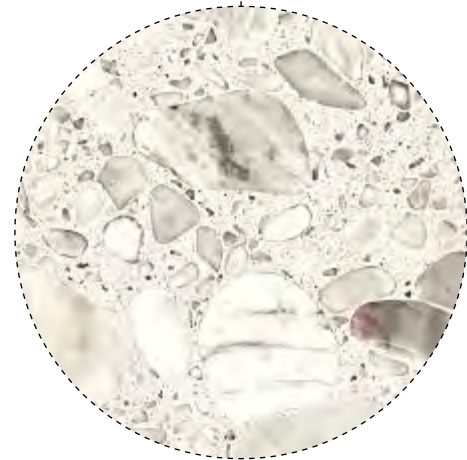

SIZES & SURFACES



120x120  
47,24"x47,24"

6,5 mm

**LARGE**

Glossy  
Rettificato | Rectified |  
Rectifié | Rektifiziert

120x120 . 47,24"x47,24"  
**SHA032**

Natural  
Rettificato | Rectified |  
Rectifié | Rektifiziert

120x120 . 47,24"x47,24"  
**SHA080**

GREY

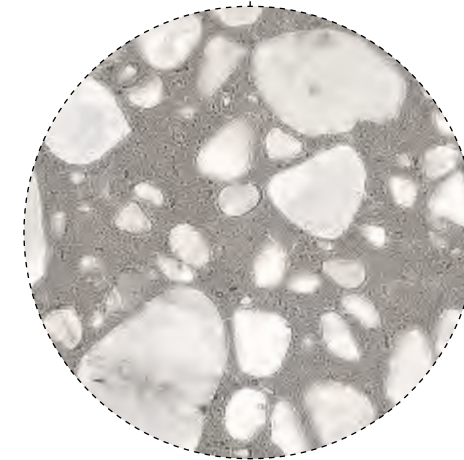

418 SHARDS\_STONE EFFECT

419 SHARDS\_STONE EFFECT

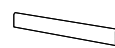

6,5 mm  
8x120 . 3,15"x47,24"  
battiscopa

**SHA033** glossy  
**SHA081** natural



6,5 mm  
33x120x5 . 12,99"x47,24"x1,97"  
gradino lineare LL

**SHA036** glossy  
**SHA084** natural



6,5 mm  
33x120x5 . 12,99"x47,24"x1,97"  
gradino angolare LL

**SHA039** glossy  
**SHA087** natural

Suggested grout  
103 . Moon White

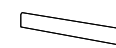

6,5 mm  
8x120 . 3,15"x47,24"  
battiscopa

**SHA035** glossy  
**SHA083** natural



6,5 mm  
33x120x5 . 12,99"x47,24"x1,97"  
gradino lineare LL

**SHA038** glossy  
**SHA086** natural

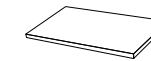

6,5 mm  
33x120x5 . 12,99"x47,24"x1,97"  
gradino angolare LL

**SHA041** glossy  
**SHA089** natural

Suggested grout  
110 . Manhattan 2000





# shards

REGISTERED DESIGN

SIZES & SURFACES



120x120  
47,24"x47,24"

6,5 mm

**LARGE**

Glossy  
Rettificato | Rectified |  
Rectifié | Rektifiziert

120x120 . 47,24"x47,24"  
**SHA031**

Natural  
Rettificato | Rectified |  
Rectifié | Rektifiziert

120x120 . 47,24"x47,24"  
**SHA079**

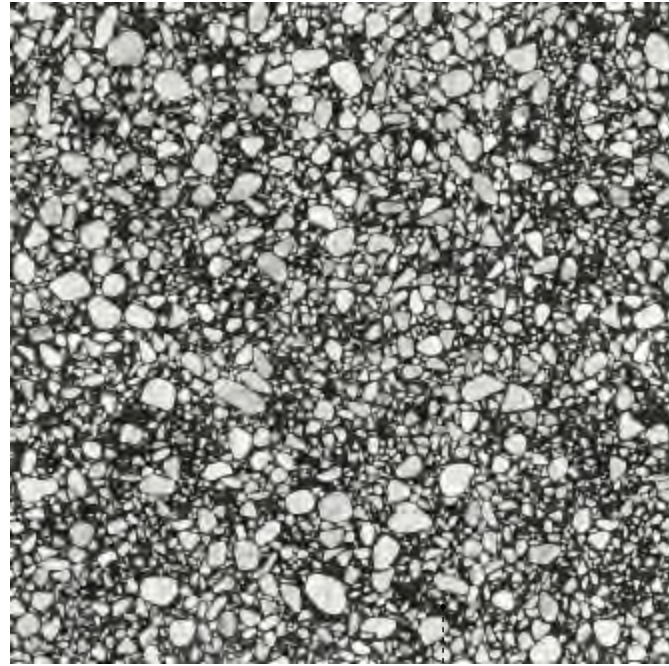

BLACK

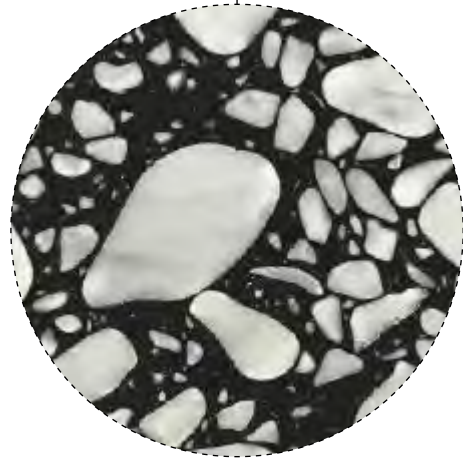

420 SHARDS\_STONE EFFECT

421 SHARDS\_STONE EFFECT



6,5 mm  
8x120 . 3,15"x47,24"  
battiscopa

**SHA034** glossy  
**SHA082** natural



6,5 mm  
33x120x5 . 12,99"x47,24"x1,97"  
gradino lineare LL

**SHA037** glossy  
**SHA085** natural



6,5 mm  
33x120x5 . 12,99"x47,24"x1,97"  
gradino angolare LL

**SHA040** glossy  
**SHA088** natural

Suggested grout  
120 . Black



LARGE BLACK / LARGE WHITE





# planeto

Lastre / piastrelle di ceramica in gres porcellanato - Gruppo Bla UGL  
 Porcelain stoneware slabs / tiles - Gruppe Bla UGL  
 Dalles / carreaux en céramique en grès cérame - Group Bla UGL  
 Keramikplatten / keramikfliesen aus Feinsteinzeug - Gruppe Bla UGL

## THICKNESS

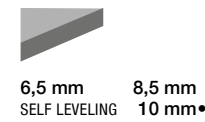

**2.OUT** 2 cm

## SURFACES

Natural / Grip  
 Rettificato | Rectified |  
 Rectifié | Rektifiziert

## TECH INFO

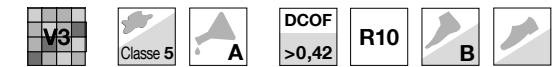

BS EN 16165\_C >  
 Dry & Wet rubber 4S:  
 on request ≥ 36  
 AS 4586 > P3: on request  
 UNE-ENV 12633 >  
 Class 2: on request



BS EN 16165\_C >  
 Dry & Wet rubber 4S: ≥ 36  
 AS 4586 > P3  
 UNE-ENV 12633 > Class 2

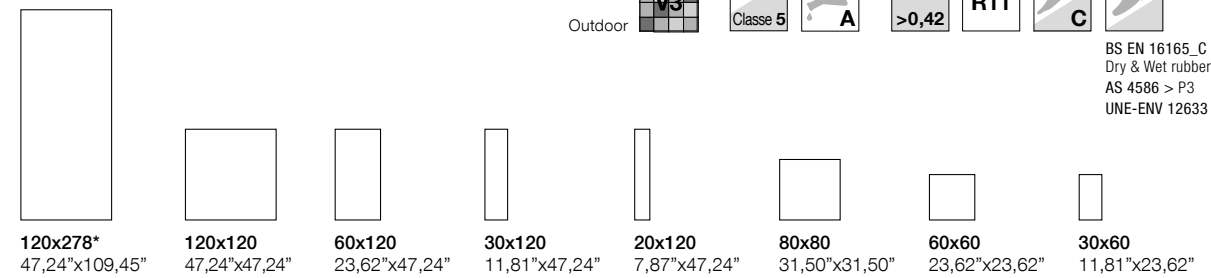

- \* Lastre realizzate attraverso impasti colorati con colori standard | Slabs produced using coloured body mix available in standard shades
- Disponibile fino ad esaurimento scorte | Available while stocks last | Disponible jusqu'à épuisement des stocks | Verfügbar solange der Vorrat reicht

## COLORS

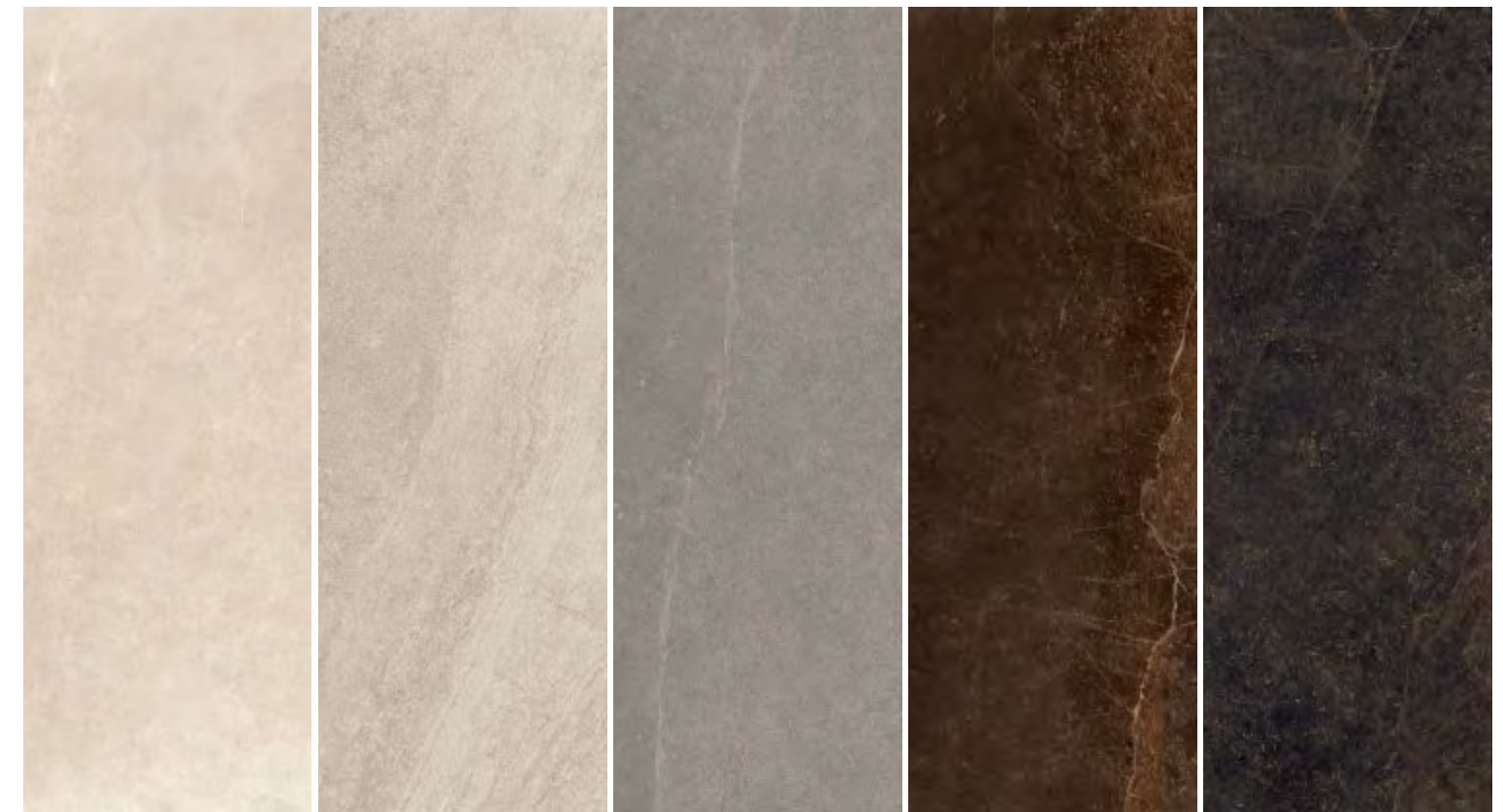

VENUS

MOON

MARS

JUPITER

PLUTO



424 PLANETO\_STONE EFFECT



MOON / JUPITER BASKET



425 PLANETO\_STONE EFFECT









428 PLANETO\_STONE EFFECT



429 PLANETO\_STONE EFFECT







# planeto



## SIZES & SURFACES



**120x278\***  
47,24"x109,45"

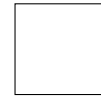

**120x120**  
47,24"x47,24"



**60x120**  
23,62"x47,24"



**30x120**  
11,81"x47,24"



**20x120**  
7,87"x47,24"



**80x80**  
31,50"x31,50"



**60x60**  
23,62"x23,62"



**30x60**  
11,81"x23,62"

## VENUS

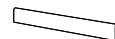

**6,5 mm PNT116**  
**8x120** . 3,15"x47,24"  
battiscopa



**6,5 mm PNT121**  
**33x120x5** . 12,99"x47,24"x1,97"  
gradino lineare LL



**6,5 mm PNT126**  
**33x120x5** . 12,99"x47,24"x1,97"  
gradino angolare LL

**8,5 mm PNT077A**  
**10 mm PNT077\***  
**8x120** . 3,15"x47,24"  
battiscopa

**8,5 mm PNT078A**  
**10 mm PNT078\***  
**33x120x5** . 12,99"x47,24"x1,97"  
gradino lineare M

**8,5 mm PNT076A**  
**10 mm PNT076\***  
**33x120x5** . 12,99"x47,24"x1,97"  
gradino angolare M

**8,5 mm PNT079A**  
**10 mm PNT079\***  
**8x60** . 3,15"x23,62"  
battiscopa

**Natural**  
Rettificato | Rectified |  
Rectifié | Rektifiziert

## 6,5 mm

**120x278** . 47,24"x109,45"  
**PNT111**

**120x120** . 47,24"x47,24"  
**PNT101**

## 8,5 mm

**60x120** . 23,62"x47,24"  
**PNT267**

**30x120** . 11,81"x47,24"  
**PNT272**

**20x120** . 7,87"x47,24"  
**PNT277**

**80x80** . 31,50"x31,50"  
**PNT297**

**60x60** . 23,62"x23,62"  
**PNT282**

**30x60** . 11,81"x23,62"  
**PNT287**

**Grip**  
Rettificato | Rectified |  
Rectifié | Rektifiziert

## 2.OUT 2 cm

**Outdoor**  
**80x80** . 31,50"x31,50"  
**PNT176**

**Natural**  
Rettificato | Rectified |  
Rectifié | Rektifiziert

## 10 mm\*

**60x120** . 23,62"x47,24"  
**PNT065**

**30x120** . 11,81"x47,24"  
**PNT066**

**20x120** . 7,87"x47,24"  
**PNT067**

**80x80** . 31,50"x31,50"  
**PNT085**

**60x60** . 23,62"x23,62"  
**PNT068**

**30x60** . 11,81"x23,62"  
**PNT070**



**8,5 mm PNT071A**  
**10 mm PNT071\***  
**30x30** . 11,81"x11,81"  
mosaico (36 pcs)



**8,5 mm PNT072A**  
**10 mm PNT072\***  
**30x26** . 11,81"x10,24"  
esagone



**8,5 mm PNT073A**  
**10 mm PNT073\***  
**30x30** . 11,81"x11,81"  
basket Venus + Jupiter



**8,5 mm PNT074A**  
**10 mm PNT074\***  
**30x30** . 11,81"x11,81"  
scraps



**8,5 mm PNT302**  
**10 mm PNT075\***  
**10x60** . 3,94"x23,62"  
chevron

• Disponibile fino ad esaurimento scorte | Available while stocks last |  
Disponibile jusqu'à épuisement des stocks | Verfügbar solange der  
Vorrat reicht

**Suggested grout**  
137 . Caribbean





# planeto

GRAPHICS 120x278

434 PLANETO\_STONE EFFECT

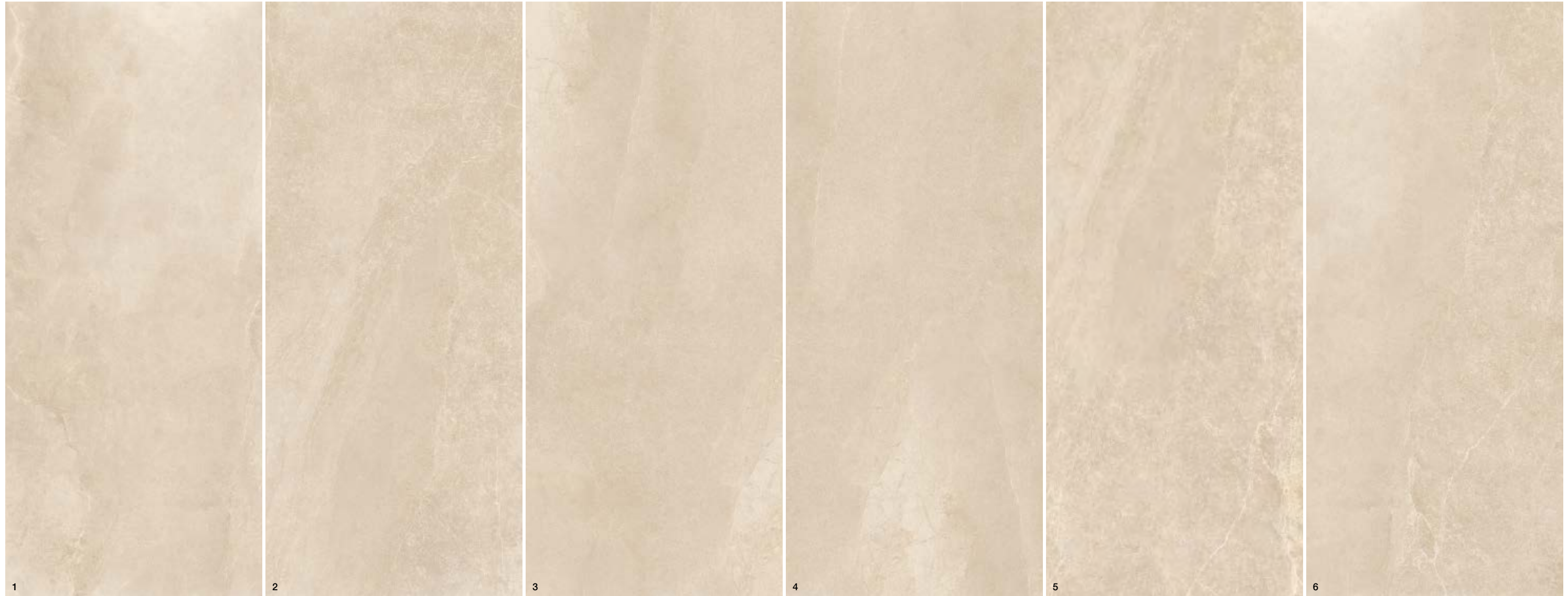

435 PLANETO\_STONE EFFECT

VENUS



# planeto



436 PLANETO\_STONE EFFECT

## SIZES & SURFACES



**120x278\***  
47,24"x109,45"



**120x120**  
47,24"x47,24"



**60x120**  
23,62"x47,24"



**30x120**  
11,81"x47,24"



**20x120**  
7,87"x47,24"



**80x80**  
31,50"x31,50"



**60x60**  
23,62"x23,62"



**30x60**  
11,81"x23,62"

**Natural**  
Rettificato | Rectified |  
Rectifié | Rektifiziert

### 6,5 mm

**120x278** . 47,24"x109,45"  
**PNT110**

**120x120** . 47,24"x47,24"  
**PNT100**

### 8,5 mm

**60x120** . 23,62"x47,24"  
**PNT268**

**30x120** . 11,81"x47,24"  
**PNT273**

**20x120** . 7,87"x47,24"  
**PNT278**

**80x80** . 31,50"x31,50"  
**PNT298**

**60x60** . 23,62"x23,62"  
**PNT283**

**30x60** . 11,81"x23,62"  
**PNT288**

**Grip**  
Rettificato | Rectified |  
Rectifié | Rektifiziert

## 2.OUT 2 cm

**Outdoor**  
**80x80** . 31,50"x31,50"  
**PNT178**

**Natural**  
Rettificato | Rectified |  
Rectifié | Rektifiziert

### 10 mm\*

**60x120** . 23,62"x47,24"  
**PNT004**

**30x120** . 11,81"x47,24"  
**PNT058**

**20x120** . 7,87"x47,24"  
**PNT008**

**80x80** . 31,50"x31,50"  
**PNT084**

**60x60** . 23,62"x23,62"  
**PNT012**

**30x60** . 11,81"x23,62"  
**PNT020**



**8,5 mm PNT024A**  
**10 mm PNT024\***  
30x30 . 11,81"x11,81"  
mosaico (36 pcs)



**8,5 mm PNT034A**  
**10 mm PNT034\***  
30x26 . 11,81"x10,24"  
esagone



**8,5 mm PNT064A**  
**10 mm PNT064\***  
30x30 . 11,81"x11,81"  
basket Moon + Jupiter



**8,5 mm PNT030A**  
**10 mm PNT030\***  
30x30 . 11,81"x11,81"  
scraps



**8,5 mm PNT303**  
**10 mm PNT038\***  
10x60 . 3,94"x23,62"  
chevron

## MOON

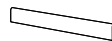

**6,5 mm PNT115**  
**8x120** . 3,15"x47,24"  
battiscopa



**6,5 mm PNT120**  
**33x120x5** . 12,99"x47,24"x1,97"  
gradino lineare LL



**6,5 mm PNT125**  
**33x120x5** . 12,99"x47,24"x1,97"  
gradino angolare LL

**8,5 mm PNT046A**  
**10 mm PNT046\***  
**8x120** . 3,15"x47,24"  
battiscopa

**8,5 mm PNT050A**  
**10 mm PNT050\***  
**33x120x5** . 12,99"x47,24"x1,97"  
gradino lineare M

**8,5 mm PNT054A**  
**10 mm PNT054\***  
**33x120x5** . 12,99"x47,24"x1,97"  
gradino angolare M

**8,5 mm PNT0042A**  
**10 mm PNT042\***  
**8x60** . 3,15"x23,62"  
battiscopa

• Disponibile fino ad esaurimento scorte | Available while stocks last |  
Disponibile jusqu'à épuisement des stocks | Verfügbar solange der  
Vorrat reicht

**Suggested grout**  
111 . Silver Grey



437 PLANETO\_STONE EFFECT



# planeto

GRAPHICS 120x278

438 PLANETO\_STONE EFFECT



MOON

439 PLANETO\_STONE EFFECT



# planeto



## SIZES & SURFACES



**120x278\***  
47,24"x109,45"



**120x120**  
47,24"x47,24"



**60x120**  
23,62"x47,24"



**30x120**  
11,81"x47,24"



**20x120**  
7,87"x47,24"



**80x80**  
31,50"x31,50"



**60x60**  
23,62"x23,62"



**30x60**  
11,81"x23,62"

**Natural**  
Rettificato | Rectified |  
Rectifié | Rektifiziert

### 6,5 mm

**120x278** . 47,24"x109,45"  
**PNT109**

**120x120** . 47,24"x47,24"  
**PNT099**

### 8,5 mm

**60x120** . 23,62"x47,24"  
**PNT269**

**30x120** . 11,81"x47,24"  
**PNT274**

**20x120** . 7,87"x47,24"  
**PNT279**

**80x80** . 31,50"x31,50"  
**PNT299**

**60x60** . 23,62"x23,62"  
**PNT284**

**30x60** . 11,81"x23,62"  
**PNT289**

**Grip**  
Rettificato | Rectified |  
Rectifié | Rektifiziert

## 2.OUT 2 cm

**Outdoor**  
**80x80** . 31,50"x31,50"  
**PNT177**

**Natural**  
Rettificato | Rectified |  
Rectifié | Rektifiziert

### 10 mm\*

**60x120** . 23,62"x47,24"  
**PNT003**

**30x120** . 11,81"x47,24"  
**PNT057**

**20x120** . 7,87"x47,24"  
**PNT007**

**80x80** . 31,50"x31,50"  
**PNT083**

**60x60** . 23,62"x23,62"  
**PNT011**

**30x60** . 11,81"x23,62"  
**PNT019**



**8,5 mm PNT023A**  
**10 mm PNT023\***  
30x30 . 11,81"x11,81"  
mosaico (36 pcs)



**8,5 mm PNT033A**  
**10 mm PNT033\***  
30x26 . 11,81"x10,24"  
esagone



**8,5 mm PNT063A**  
**10 mm PNT063\***  
30x30 . 11,81"x11,81"  
basket Mars + Pluto



**8,5 mm PNT029A**  
**10 mm PNT029\***  
30x30 . 11,81"x11,81"  
scraps



**8,5 mm PNT304**  
**10 mm PNT037\***  
10x60 . 3,94"x23,62"  
chevron

## MARS

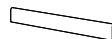

**6,5 mm PNT114**  
**8x120** . 3,15"x47,24"  
battiscopa



**6,5 mm PNT119**  
**33x120x5** . 12,99"x47,24"x1,97"  
gradino lineare LL



**6,5 mm PNT124**  
**33x120x5** . 12,99"x47,24"x1,97"  
gradino angolare LL

**8,5 mm PNT045A**  
**10 mm PNT045\***  
**8x120** . 3,15"x47,24"  
battiscopa

**8,5 mm PNT049A**  
**10 mm PNT049\***  
**33x120x5** . 12,99"x47,24"x1,97"  
gradino lineare M

**8,5 mm PNT053A**  
**10 mm PNT053\***  
**33x120x5** . 12,99"x47,24"x1,97"  
gradino angolare M

**8,5 mm PNT041A**  
**10 mm PNT041\***  
**8x60** . 3,15"x23,62"  
battiscopa

- Disponibile fino ad esaurimento scorte | Available while stocks last |  
Disponibile jusqu'à épuisement des stocks | Verfügbar solange der  
Vorrat reicht

**Suggested grout**  
113 . Cement Grey





# planeto

GRAPHICS 120x278

442 PLANETO\_STONE EFFECT



MARS

443 PLANETO\_STONE EFFECT



# planeto



## SIZES & SURFACES



**120x278\***  
47,24"x109,45"

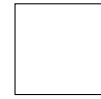

**120x120**  
47,24"x47,24"



**60x120**  
23,62"x47,24"



**30x120**  
11,81"x47,24"



**20x120**  
7,87"x47,24"



**80x80**  
31,50"x31,50"



**60x60**  
23,62"x23,62"



**30x60**  
11,81"x23,62"

**Natural**  
Rettificato | Rectified |  
Rectifié | Rektifiziert

### 6,5 mm

**120x278** . 47,24"x109,45"  
**PNT108**

**120x120** . 47,24"x47,24"  
**PNT098**

### 8,5 mm

**60x120** . 23,62"x47,24"  
**PNT270**

**30x120** . 11,81"x47,24"  
**PNT275**

**20x120** . 7,87"x47,24"  
**PNT0280**

**80x80** . 31,50"x31,50"  
**PNT300**

**60x60** . 23,62"x23,62"  
**PNT285**

**30x60** . 11,81"x23,62"  
**PNT290**

**Grip**  
Rettificato | Rectified |  
Rectifié | Rektifiziert

## 2.OUT 2 cm

**Outdoor**  
**80x80** . 31,50"x31,50"  
**PNT179**

**Natural**  
Rettificato | Rectified |  
Rectifié | Rektifiziert

### 10 mm\*

**60x120** . 23,62"x47,24"  
**PNT002**

**30x120** . 11,81"x47,24"  
**PNT056**

**20x120** . 7,87"x47,24"  
**PNT006**

**80x80** . 31,50"x31,50"  
**PNT082**

**60x60** . 23,62"x23,62"  
**PNT010**

**30x60** . 11,81"x23,62"  
**PNT018**

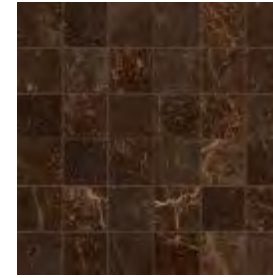

**8,5 mm PNT022A**  
**10 mm PNT022\***  
30x30 . 11,81"x11,81"  
mosaico (36 pcs)



**8,5 mm PNT032A**  
**10 mm PNT032\***  
30x26 . 11,81"x10,24"  
esagone



**8,5 mm PNT026A**  
**10 mm PNT026\***  
30x30 . 11,81"x11,81"  
basket Jupiter + Moon



**8,5 mm PNT028A**  
**10 mm PNT028\***  
30x30 . 11,81"x11,81"  
scraps



**8,5 mm PNT305**  
**10 mm PNT036\***  
10x60 . 3,94"x23,62"  
chevron

## JUPITER

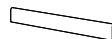

**6,5 mm PNT113**  
**8x120** . 3,15"x47,24"  
battiscopa



**6,5 mm PNT118**  
**33x120x5** . 12,99"x47,24"x1,97"  
gradino lineare LL



**6,5 mm PNT123**  
**33x120x5** . 12,99"x47,24"x1,97"  
gradino angolare LL

**8,5 mm PNT044A**  
**10 mm PNT044\***  
**8x120** . 3,15"x47,24"  
battiscopa

**8,5 mm PNT048A**  
**10 mm PNT048\***  
**33x120x5** . 12,99"x47,24"x1,97"  
gradino lineare M

**8,5 mm PNT052A**  
**10 mm PNT052\***  
**33x120x5** . 12,99"x47,24"x1,97"  
gradino angolare M

**8,5 mm PNT040A**  
**10 mm PNT040\***  
**8x60** . 3,15"x23,62"  
battiscopa

- Disponibile fino ad esaurimento scorte | Available while stocks last |  
Disponibile jusqu'à épuisement des stocks | Verfügbar solange der  
Vorrat reicht

### Suggested grout

136 . Mud





# planeto

GRAPHICS 120x278

446 PLANETO\_STONE EFFECT



JUPITER

447 PLANETO\_STONE EFFECT



# planeto

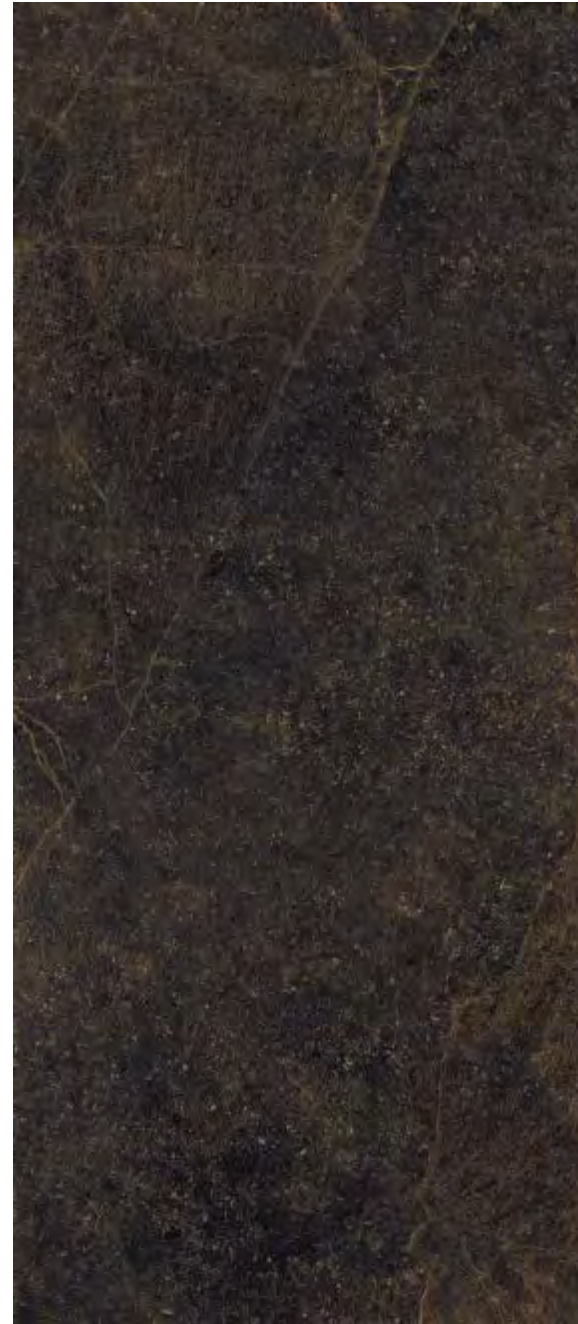

448 PLANETO\_STONE EFFECT

## SIZES & SURFACES



**120x278\***  
47,24"x109,45"



**120x120**  
47,24"x47,24"



**60x120**  
23,62"x47,24"



**30x120**  
11,81"x47,24"



**20x120**  
7,87"x47,24"



**80x80**  
31,50"x31,50"



**60x60**  
23,62"x23,62"



**30x60**  
11,81"x23,62"

**Natural**  
Rettificato | Rectified |  
Rectifié | Rektifiziert

### 6,5 mm

**120x278** . 47,24"x109,45"  
**PNT107**

**120x120** . 47,24"x47,24"  
**PNT097**

### 8,5 mm

**60x120** . 23,62"x47,24"  
**PNT271**

**30x120** . 11,81"x47,24"  
**PNT276**

**20x120** . 7,87"x47,24"  
**PNT281**

**80x80** . 31,50"x31,50"  
**PNT301**

**60x60** . 23,62"x23,62"  
**PNT286**

**30x60** . 11,81"x23,62"  
**PNT291**

**Natural**  
Rettificato | Rectified |  
Rectifié | Rektifiziert

### 10 mm\*

**60x120** . 23,62"x47,24"  
**PNT001**

**30x120** . 11,81"x47,24"  
**PNT055**

**20x120** . 7,87"x47,24"  
**PNT005**

**80x80** . 31,50"x31,50"  
**PNT081**

**60x60** . 23,62"x23,62"  
**PNT009**

**30x60** . 11,81"x23,62"  
**PNT017**



**8,5 mm PNT021A**  
**10 mm PNT021\***  
30x30 . 11,81"x11,81"  
mosaico (36 pcs)



**8,5 mm PNT031A**  
**10 mm PNT031\***  
30x26 . 11,81"x10,24"  
esagone



**8,5 mm PNT025A**  
**10 mm PNT025\***  
30x30 . 11,81"x11,81"  
basket Pluto + Mars



**8,5 mm PNT027A**  
**10 mm PNT027\***  
30x30 . 11,81"x11,81"  
scraps



**8,5 mm PNT306**  
**10 mm PNT035\***  
10x60 . 3,94"x23,62"  
chevron

## PLUTO

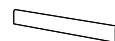

**6,5 mm PNT112**  
8x120 . 3,15"x47,24"  
battiscopa



**6,5 mm PNT117**  
33x120x5 . 12,99"x47,24"x1,97"  
gradino lineare LL



**6,5 mm PNT122**  
33x120x5 . 12,99"x47,24"x1,97"  
gradino angolare LL

**8,5 mm PNT043A**  
**10 mm PNT043\***  
8x120 . 3,15"x47,24"  
battiscopa

**8,5 mm PNT047A**  
**10 mm PNT047\***  
33x120x5 . 12,99"x47,24"x1,97"  
gradino lineare M

**8,5 mm PNT051A**  
**10 mm PNT051\***  
33x120x5 . 12,99"x47,24"x1,97"  
gradino angolare M

**8,5 mm PNT039A**  
**10 mm PNT039\***  
8x60 . 3,15"x23,62"  
battiscopa

• Disponibile fino ad esaurimento scorte | Available while stocks last |  
Disponibile jusqu'à épuisement des stocks | Verfügbar solange der  
Vorrat reicht

**Suggested grout**  
149 . Volcano Sand



449 PLANETO\_STONE EFFECT



# planeto

GRAPHICS 120x278

450 PLANETO\_STONE EFFECT



451 PLANETO\_STONE EFFECT

PLUTO



# pezzi speciali

Special trims | Pièces spéciales | Formteile

## 2.0UT

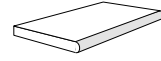

**2 cm**  
40x80x2 . 15,75"x31,50"x0,78"  
gradone toro lineare  
**PNT183** Venus  
**PNT221** Moon  
**PNT202** Mars  
**PNT240** Jupiter

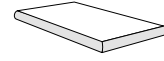

**2 cm**  
40x80x2 . 15,75"x31,50"x0,78"  
gradone toro angolare dx  
**PNT184** Venus  
**PNT222** Moon  
**PNT203** Mars  
**PNT241** Jupiter

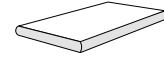

**2 cm**  
40x80x2 . 15,75"x31,50"x0,78"  
gradone toro angolare sx  
**PNT185** Venus  
**PNT223** Moon  
**PNT204** Mars  
**PNT242** Jupiter

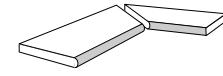

**2 cm**  
40x80x2 . 15,75"x31,50"x0,78"  
comp. gradone toro ang. interno  
**PNT186** Venus  
**PNT224** Moon  
**PNT205** Mars  
**PNT243** Jupiter

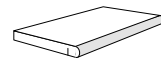

**2 cm**  
40x80x2 . 15,75"x31,50"x0,78"  
gradone toro lineare nodrip  
**PNT187** Venus  
**PNT225** Moon  
**PNT206** Mars  
**PNT244** Jupiter

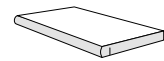

**2 cm**  
40x80x2 . 15,75"x31,50"x0,78"  
gradone toro angolare dx nodrip  
**PNT188** Venus  
**PNT226** Moon  
**PNT207** Mars  
**PNT245** Jupiter

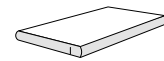

**2 cm**  
40x80x2 . 15,75"x31,50"x0,78"  
gradone toro angolare sx nodrip  
**PNT189** Venus  
**PNT227** Moon  
**PNT208** Mars  
**PNT246** Jupiter

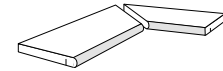

**2 cm**  
40x80x2 . 15,75"x31,50"x0,78"  
comp. gradone toro ang. interno nodrip  
**PNT190** Venus  
**PNT228** Moon  
**PNT209** Mars  
**PNT247** Jupiter

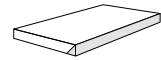

**2 cm**  
40x80x2 . 15,75"x31,50"x0,78"  
gradone cover lineare  
**PNT194** Venus  
**PNT232** Moon  
**PNT213** Mars  
**PNT251** Jupiter

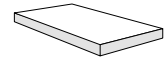

**2 cm**  
40x80x2 . 15,75"x31,50"x0,78"  
gradone cover angolare dx  
**PNT195** Venus  
**PNT233** Moon  
**PNT214** Mars  
**PNT252** Jupiter

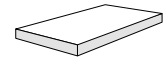

**2 cm**  
40x80x2 . 15,75"x31,50"x0,78"  
gradone cover angolare sx  
**PNT196** Venus  
**PNT234** Moon  
**PNT215** Mars  
**PNT253** Jupiter

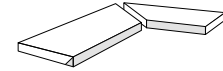

**2 cm**  
40x80x2 . 15,75"x31,50"x0,78"  
comp. gradone cover ang. interno  
**PNT197** Venus  
**PNT235** Moon  
**PNT216** Mars  
**PNT254** Jupiter

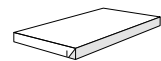

**2 cm**  
40x80x2 . 15,75"x31,50"x0,78"  
gradone cover lineare nodrip  
**PNT198** Venus  
**PNT236** Moon  
**PNT217** Mars  
**PNT255** Jupiter

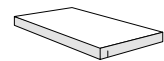

**2 cm**  
40x80x2 . 15,75"x31,50"x0,78"  
gradone cover angolare dx nodrip  
**PNT199** Venus  
**PNT237** Moon  
**PNT218** Mars  
**PNT256** Jupiter

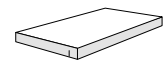

**2 cm**  
40x80x2 . 15,75"x31,50"x0,78"  
gradone cover angolare sx nodrip  
**PNT200** Venus  
**PNT238** Moon  
**PNT219** Mars  
**PNT257** Jupiter

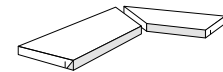

**2 cm**  
40x80x2 . 15,75"x31,50"x0,78"  
comp. gradone cover ang. interno nodrip  
**PNT201** Venus  
**PNT239** Moon  
**PNT220** Mars  
**PNT258** Jupiter



**2 cm**  
40x80x5 . 15,75"x31,50"x1,97"  
elemento L lineare  
**PNT191** Venus  
**PNT229** Moon  
**PNT210** Mars  
**PNT248** Jupiter

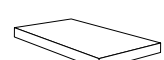

**2 cm**  
40x80x5 . 15,75"x31,50"x1,97"  
elemento L angolare dx  
**PNT192** Venus  
**PNT230** Moon  
**PNT211** Mars  
**PNT249** Jupiter



**2 cm**  
40x80x5 . 15,75"x31,50"x1,97"  
elemento L angolare sx  
**PNT193** Venus  
**PNT231** Moon  
**PNT212** Mars  
**PNT250** Jupiter

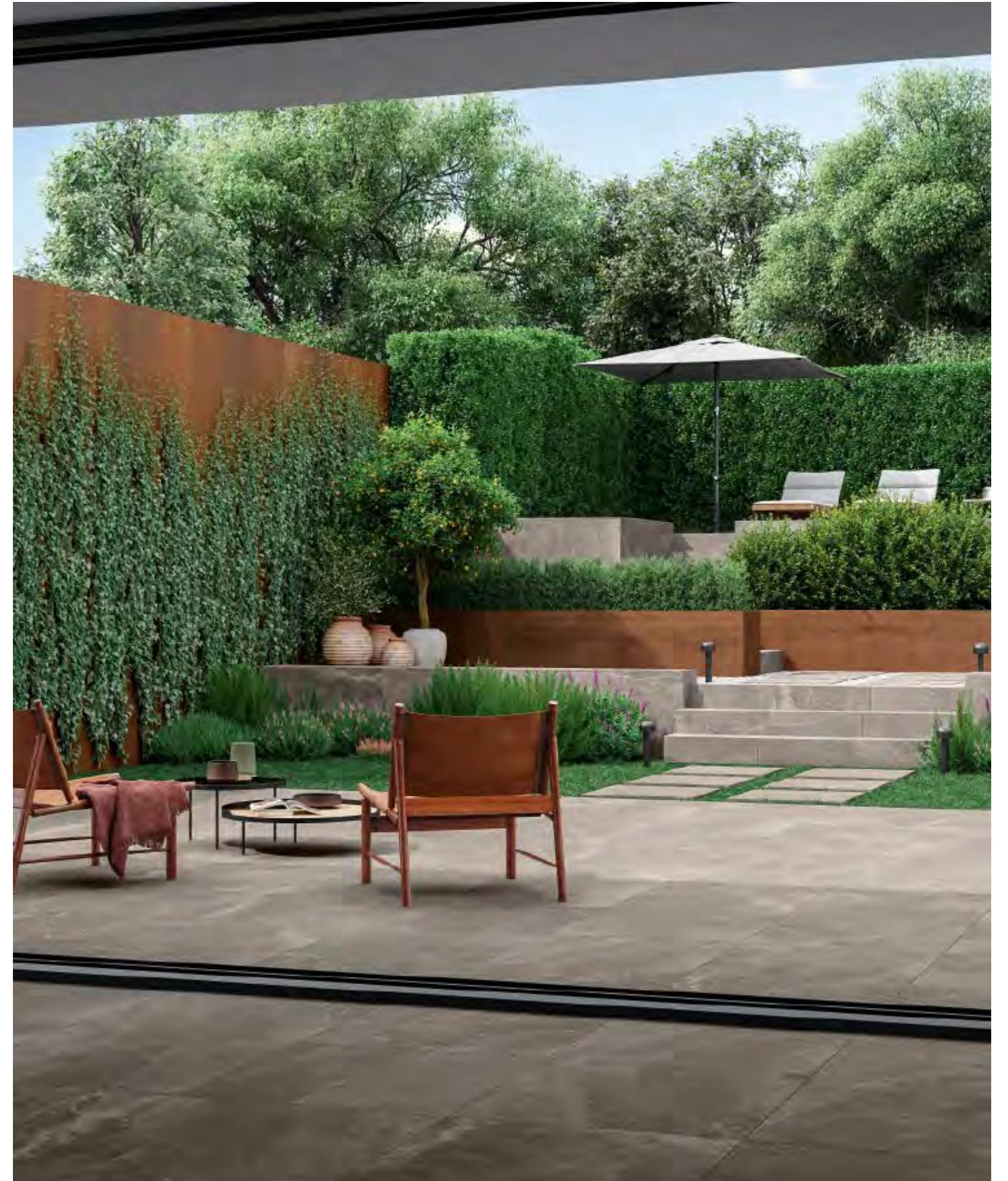

452 PLANETO\_STONE EFFECT

453 PLANETO\_STONE EFFECT

I pezzi speciali sono disponibili su richiesta | Trim tiles are available on request | Les pièces spéciales sont disponibles sur demande | Die Formteile sind auf Anfrage erhältlich

MARS 2.0UT







# stone lab



456 STONE LAB\_STONE EFFECT

## SIZES & SURFACES

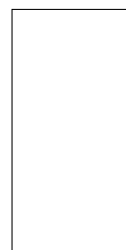

160x320\*  
62,99"x125,98"

**Natural**  
Rettificato | Rectified |  
Rectifié | Rektifiziert

**6,5 mm**

- 160x320 . 62,99"x125,98"  
**STL049**

SILVER STONE

- Disponibile su richiesta | Available on request | Disponible sur demande |  
Auf Anfrage erhältlich

**Suggested grout**  
127 . Arctic Grey



457 STONE LAB\_STONE EFFECT

SILVER STONE



# stone lab

GRAPHICS 160x320

458 STONE LAB\_STONE EFFECT



SILVER STONE



459 STONE LAB\_STONE EFFECT

160x320\_Prodotto con 4 diverse grafiche confezionate in modo casuale | Produced with a variety of a range of 4 different graphic designs which are randomly combined and then packed | Produit avec 4 différents graphismes conditionnés de façon fortuite | Mit 4 unterschiedlichen Graphiken hergestellt und mit einer zufälliger Auswahl verpackt



# stone lab

## SIZES & SURFACES



100x100  
39,37"x39,37"

**Grip**  
Rettificato | Rectified |  
Rectifié | Rektifiziert

**2.0UT 2 cm**

**Outdoor**  
100x100 . 39,37"x39,37"  
**STL058**



CEPPO

# pezzi speciali

Special trims | Pièces spéciales | Formteile

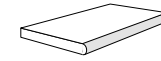

**2 cm**  
**40x100x2** . 15,75"x39,37"x0,78"  
gradone toro lineare  
**STL065** *Ceppo*



**2 cm**  
**40x100x2** . 15,75"x39,37"x0,78"  
gradone toro angolare dx  
**STL066** *Ceppo*

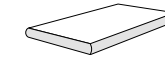

**2 cm**  
**40x100x2** . 15,75"x39,37"x0,78"  
gradone toro angolare sx  
**STL067** *Ceppo*

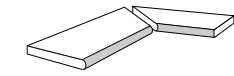

**2 cm**  
**40x100x2** . 15,75"x39,37"x0,78"  
comp. gradone toro ang. interno  
**STL069** *Ceppo*

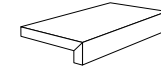

**2 cm**  
**40x100x5** . 15,75"x39,37"x1,97"  
elemento L lineare  
**STL068** *Ceppo*

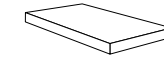

**2 cm**  
**40x100x5** . 15,75"x39,37"x1,97"  
elemento L angolare dx  
**STL070** *Ceppo*

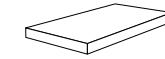

**2 cm**  
**40x100x5** . 15,75"x39,37"x1,97"  
elemento L angolare sx  
**STL071** *Ceppo*

2.0UT





462 THE COLLECTIONS\_WOOD EFFECT

Effetto Legno  
Effet Bois  
Holz-Effekt

# wood effect

464 Woodblock  
476 Komi

463 THE COLLECTIONS\_WOOD EFFECT



# woodblock



Lastre di ceramica in gres porcellanato - Gruppo Bla GL  
Porcelain stoneware slabs - Gruppe Bla GL  
Dalles en céramique en grès cérame - Group Bla GL  
Keramikplatten aus Feinsteinzeug - Gruppe Bla GL

## THICKNESS



6,5 mm  
SELF LEVELING

## SURFACES

Real Matt  
3D Texture  
Rettificato | Rectified |  
Rectifié | Rektifiziert

## TECH INFO



Brave

BS EN 16165\_C >  
Dry & Wet rubber 4S: ≥ 36  
AS 4586 > P3  
UNE-ENV 12633 > Class 2



40x240  
15,75"x94,49"



24x240  
9,45"x94,49"



24x120  
9,45"x47,24"

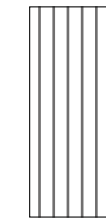

120x278 STRIPY  
47,24"x109,45"



120x278 GROOVE  
47,24"x109,45"

## COLORS



BRAVE OAK



BALANCE OAK



SCRATCH OAK





BRAVE STRIPY OAK



BRAVE OAK / BRAVE STRIPY OAK







# woodblock



## SIZES & SURFACES



**40x240**  
15,75"x94,49"



**24x240**  
9,45"x94,49"



**24x120**  
9,45"x47,24"

**Real Matt**  
**3D Texture**  
Rettificato | Rectified |  
Rectifié | Rektifiziert

**6,5 mm**

**40x240** . 15,75"x94,49"  
**WOB003**

**24x240** . 9,45"x94,49"  
**WOB004**

**24x120** . 9,45"x47,24"  
**WOB005**



470 WOODBLOCK\_WOOD EFFECT



**BRAVE OAK**

471 WOODBLOCK\_WOOD EFFECT



**BRAVE STRIPY OAK**

**6,5 mm**  
**120x278** . 47,24"x109,45"  
decoro  
**WOB013**

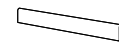

**6,5 mm**  
**5x120** . 1,97"x47,24"  
battiscopa  
**WOB020**



**6,5 mm**  
**33x120x5** . 12,99"x47,24"x1,97"  
gradino lineare LL  
**WOB023**



**6,5 mm**  
**33x120x5** . 12,99"x47,24"x1,97"  
gradino angolare LL  
**WOB026**

**Suggested grout**  
188 . Biscuit



**Suggested grout**  
188 . Biscuit





# woodblock



## SIZES & SURFACES



**40x240**  
15,75"x94,49"



**24x240**  
9,45"x94,49"



**24x120**  
9,45"x47,24"

**Real Matt**  
**3D Texture**  
Rettificato | Rectified |  
Rectifié | Rektifiziert

**6,5 mm**

**40x240** . 15,75"x94,49"  
**WOB008**

**24x240** . 9,45"x94,49"  
**WOB009**

**24x120** . 9,45"x47,24"  
**WOB010**



472 WOODBLOCK\_WOOD EFFECT



**BALANCE OAK**

473 WOODBLOCK\_WOOD EFFECT



**BALANCE GROOVE OAK**

**6,5 mm**  
**120x278** . 47,24"x109,45"  
deco  
**WOB014**

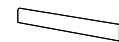

**6,5 mm**  
**5x120** . 1,97"x47,24"  
battiscopa  
**WOB021**



**6,5 mm**  
**33x120x5** . 12,99"x47,24"x1,97"  
gradino lineare LL  
**WOB024**



**6,5 mm**  
**33x120x5** . 12,99"x47,24"x1,97"  
gradino angolare LL  
**WOB027**

**Suggested grout**  
188 . Biscuit



**Suggested grout**  
134 . Silk





# woodblock



## SIZES & SURFACES



**40x240**  
15,75"x94,49"



**24x240**  
9,45"x94,49"



**24x120**  
9,45"x47,24"

**Real Matt**  
**3D Texture**  
Rettificato | Rectified |  
Rectifié | Rektifiziert

**6,5 mm**

**40x240** . 15,75"x94,49"  
**WOB017**

**24x240** . 9,45"x94,49"  
**WOB018**

**24x120** . 9,45"x47,24"  
**WOB019**

**Suggested grout**  
188 . Biscuit



SCRATCH OAK

474 WOODBLOCK\_WOOD EFFECT

475 WOODBLOCK\_WOOD EFFECT

## SUGGERIMENTI DI POSA | LAYING SUGGESTIONS | CONSEILS POUR LA POSE | VERLEGETIPPS

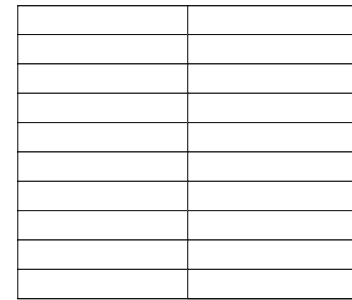

40x240 (100%)

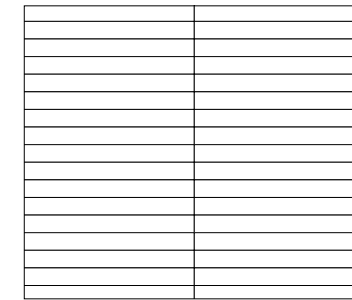

24x240 (100%)

## POSE SFALSATE | STAGGERED LAYING DESIGNS | POSES EN DÉCALÉ | VERSETZTE VERLEGUNG

Si raccomanda di sfalsare almeno di 1/3 rispetto alla lunghezza della lastra | The slabs should be staggered by at least one third of their length | Il est recommandé de poser le produit en le décalant d'au moins 1/3 de la longueur de la dalle | Es wird empfohlen, die Fliesen um mindestens 1/3 bezüglich der Länge der Fliese gegeneinander versetzt zu verlegen

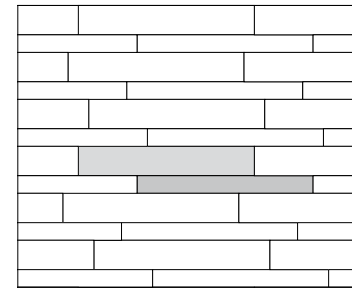

40x240 (62,5%)  
24x240 (37,5%)

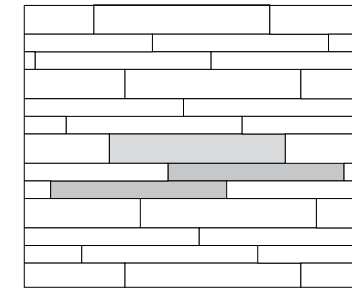

40x240 (45,45%)  
24x240 (54,55%)

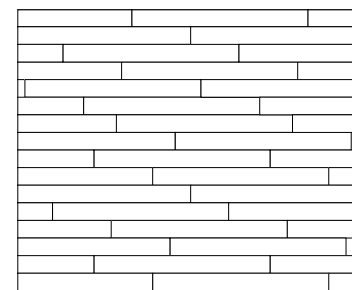

24x240 (100%)

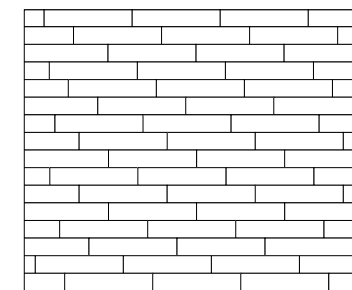

24x120 (100%)

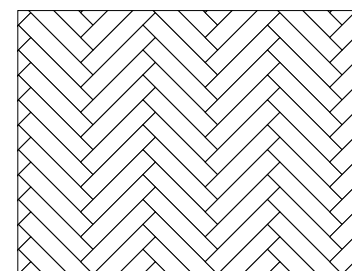

24x120 (100%)

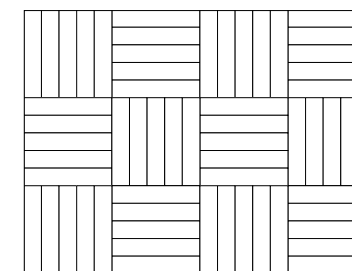

24x120 (100%)

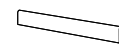

**6,5 mm**  
**5x120** . 1,97"x47,24"  
battiscopa  
**WOB022**



**6,5 mm**  
**33x120x5** . 12,99"x47,24"x1,97"  
gradino lineare LL  
**WOB025**



**6,5 mm**  
**33x120x5** . 12,99"x47,24"x1,97"  
gradino angolare LL  
**WOB028**





# komi

Lastre di ceramica in gres porcellanato - Gruppo Bla GL  
Porcelain stoneware slabs - Gruppe Bla GL  
Dalles en céramique en grès cérame - Group Bla GL  
Keramikplatten aus Feinsteinzeug - Gruppe Bla GL

### THICKNESS



6,5 mm  
SELF LEVELING

**2.OUT** 2 cm

### SURFACES

**Natural / Grip**  
Rettificato | Rectified |  
Rectifié | Rektifiziert

### TECH INFO

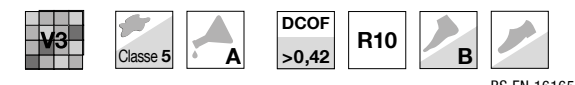

BS EN 16165\_C >  
Dry & Wet rubber 4S: ≥ 36  
AS 4586 > P3  
UNE-ENV 12633 > Class 2

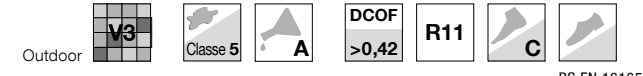

BS EN 16165\_C >  
Dry & Wet rubber 4S: ≥ 36  
AS 4586 > P3  
UNE-ENV 12633 > Class 2

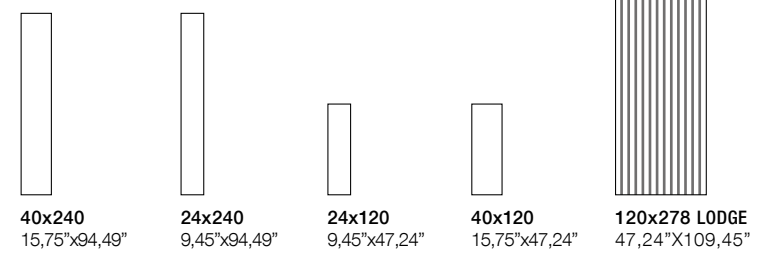

### COLORS



ORIGINAL NATURAL TRADITIONAL ELEGANT CLASSIC







480 KOMI\_WOOD EFFECT



NATURAL



481 KOMI\_WOOD EFFECT

CLASSIC





482 KOMI\_WOOD EFFECT

ELEGANT



483 KOMI\_WOOD EFFECT

TRADITIONAL



# komi

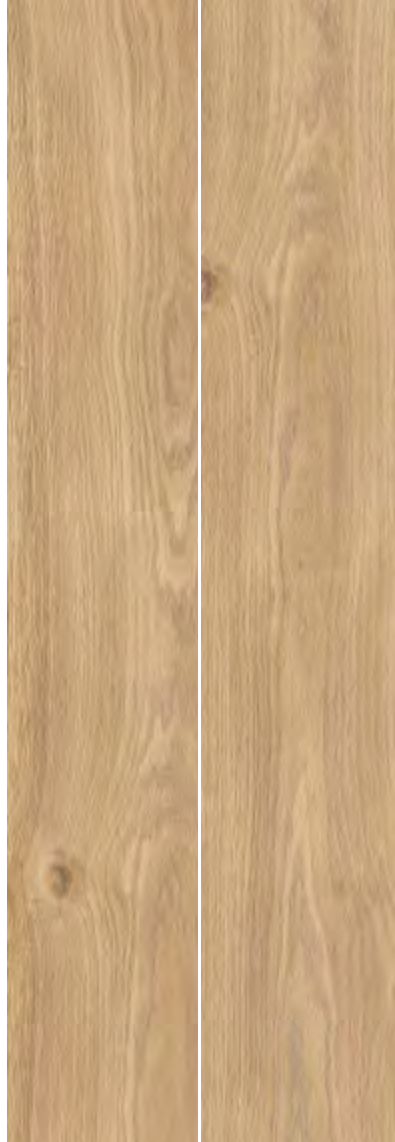

484 KOMI\_WOOD EFFECT

ORIGINAL

## SIZES & SURFACES



**40x240**  
15,75"x94,49"



**24x240**  
9,45"x94,49"



**24x120**  
9,45"x47,24"



**40x120**  
15,75"x47,24"

**Natural**  
Rettificato | Rectified |  
Rectifié | Rektifiziert

### 6,5 mm

**40x240** . 15,75"x94,49"  
**KOM018**

**24x240** . 9,45"x94,49"  
**KOM019**

**24x120** . 9,45"x47,24"  
**KOM096**

**Grip**  
Rettificato | Rectified |  
Rectifié | Rektifiziert

### 2.OUT 2 cm

**Outdoor**  
**40x120** . 15,75"x47,24"  
**KOM136**

## LAYING EXAMPLE



485 KOMI\_WOOD EFFECT



**6,5 mm**  
**5x120** . 1,97"x47,24"  
battiscopa  
**KOM043**



**6,5 mm**  
**33x120x5** . 12,99"x47,24"x1,97"  
gradino lineare LL  
**KOM049**



**6,5 mm**  
**33x120x5** . 12,99"x47,24"x1,97"  
gradino angolare LL  
**KOM050**

**Suggested grout**  
188 . Bisquit





# komi

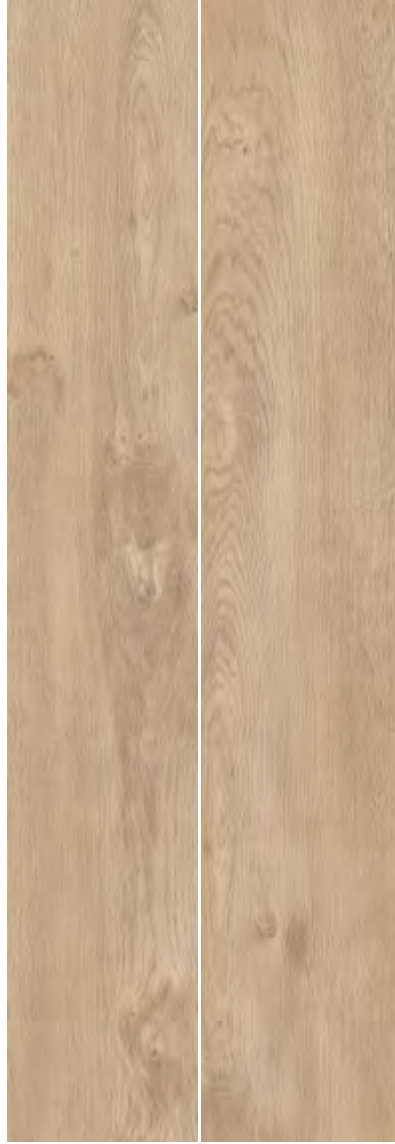

486 KOMI\_WOOD EFFECT

## SIZES & SURFACES



**40x240**  
15,75"x94,49"



**24x240**  
9,45"x94,49"



**24x120**  
9,45"x47,24"



**40x120**  
15,75"x47,24"

**Natural**  
Rettificato | Rectified |  
Rectifié | Rektifiziert

### 6,5 mm

**40x240** . 15,75"x94,49"  
**KOM002**

**24x240** . 9,45"x94,49"  
**KOM003**

**24x120** . 9,45"x47,24"  
**KOM095**

**Grip**  
Rettificato | Rectified |  
Rectifié | Rektifiziert

### 2.OUT 2 cm

**Outdoor**  
**40x120** . 15,75"x47,24"  
**KOM135**

## LAYING EXAMPLE



487 KOMI\_WOOD EFFECT

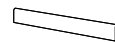

**6,5 mm**  
**5x120** . 1,97"x47,24"  
battiscopa  
**KOM041**



**6,5 mm**  
**33x120x5** . 12,99"x47,24"x1,97"  
gradino lineare LL  
**KOM045**



**6,5 mm**  
**33x120x5** . 12,99"x47,24"x1,97"  
gradino angolare LL  
**KOM046**

**Suggested grout**  
138 . Almond





# komi



488 KOMI\_WOOD EFFECT

## SIZES & SURFACES



**40x240**  
15,75"x94,49"



**24x240**  
9,45"x94,49"



**24x120**  
9,45"x47,24"



**40x120**  
15,75"x47,24"

**Natural**  
Rettificato | Rectified |  
Rectifié | Rektifiziert

### 6,5 mm

**40x240** . 15,75"x94,49"  
**KOM026**

**24x240** . 9,45"x94,49"  
**KOM027**

**24x120** . 9,45"x47,24"  
**KOM097**

**Grip**  
Rettificato | Rectified |  
Rectifié | Rektifiziert

### 2.OUT 2 cm

**Outdoor**  
**40x120** . 15,75"x47,24"  
**KOM134**

## LAYING EXAMPLE



489 KOMI\_WOOD EFFECT

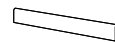

**6,5 mm**  
**5x120** . 1,97"x47,24"  
battiscopa  
**KOM044**



**6,5 mm**  
**33x120x5** . 12,99"x47,24"x1,97"  
gradino lineare LL  
**KOM051**



**6,5 mm**  
**33x120x5** . 12,99"x47,24"x1,97"  
gradino angolare LL  
**KOM052**

**Suggested grout**  
135 . Golden Dust





# komi



490 KOMI\_WOOD EFFECT

## SIZES & SURFACES



**40x240**  
15,75"x94,49"



**24x240**  
9,45"x94,49"



**24x120**  
9,45"x47,24"

**Natural**  
Rettificato | Rectified |  
Rectifié | Rektifiziert

**6,5 mm**

**40x240** . 15,75"x94,49"  
**KOM106**

**24x240** . 9,45"x94,49"  
**KOM108**

**24x120** . 9,45"x47,24"  
**KOM104**

## LAYING EXAMPLE



491 KOMI\_WOOD EFFECT

**ELEGANT**

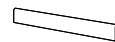

**6,5 mm**  
**5x120** . 1,97"x47,24"  
battiscopa  
**KOM110**



**6,5 mm**  
**33x120x5** . 12,99"x47,24"x1,97"  
gradino lineare LL  
**KOM112**



**6,5 mm**  
**33x120x5** . 12,99"x47,24"x1,97"  
gradino angolare LL  
**KOM114**

**Suggested grout**  
135 . Golden Dust





# komi

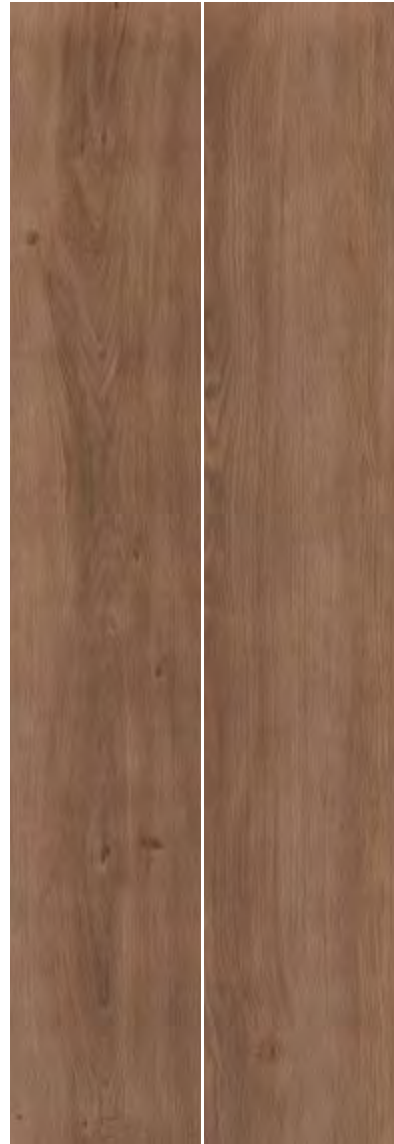

492 KOMI\_WOOD EFFECT

## SIZES & SURFACES



**40x240**  
15,75"x94,49"



**24x240**  
9,45"x94,49"



**24x120**  
9,45"x47,24"

**Natural**  
Rettificato | Rectified |  
Rectifié | Rektifiziert

**6,5 mm**

**40x240** . 15,75"x94,49"  
**KOM107**

**24x240** . 9,45"x94,49"  
**KOM109**

**24x120** . 9,45"x47,24"  
**KOM105**

## LAYING EXAMPLE

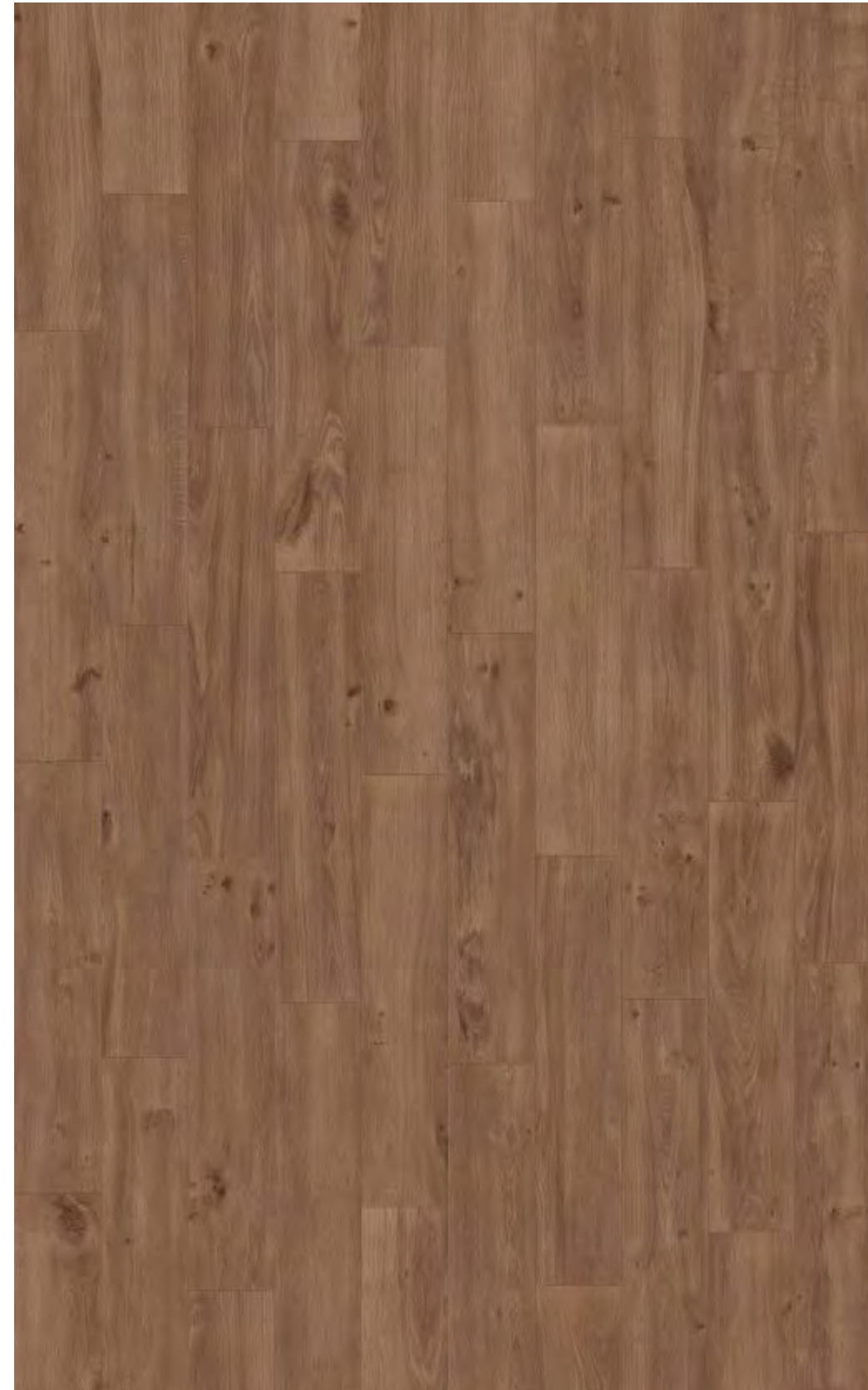

493 KOMI\_WOOD EFFECT

**CLASSIC**

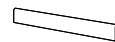

**6,5 mm**  
**5x120** . 1,97"x47,24"  
battiscopa  
**KOM111**



**6,5 mm**  
**33x120x5** . 12,99"x47,24"x1,97"  
gradino lineare LL  
**KOM113**



**6,5 mm**  
**33x120x5** . 12,99"x47,24"x1,97"  
gradino angolare LL  
**KOM115**

**Suggested grout**  
152 . Liquorice





# komi

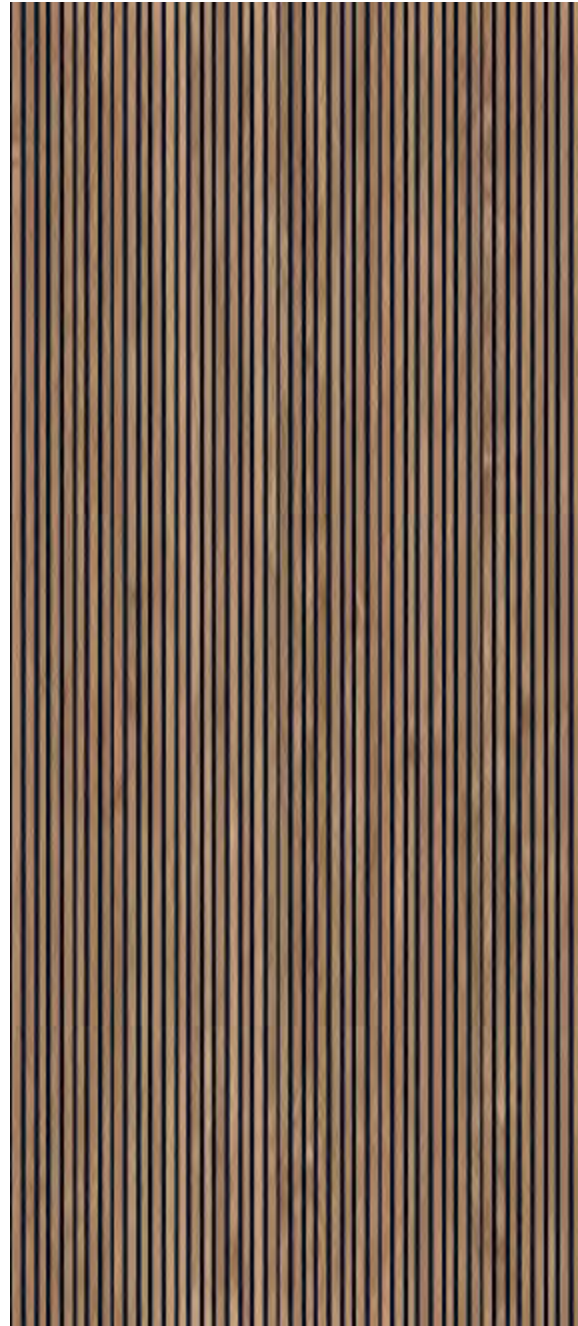

494 KOMI\_WOOD\_EFFECT

## LODGE ELEGANT

6,5 mm  
120x278 . 47,24"x109,45"  
deco  
KOM124

Suggested grout  
114 . Anthracite



### SUGGERIMENTI DI POSA | LAYING SUGGESTIONS | CONSEILS POUR LA POSE | VERLEGETIPPS

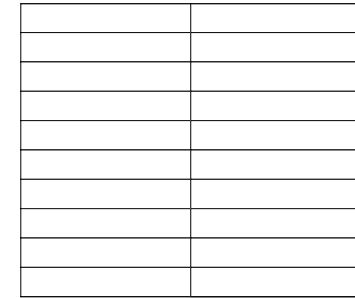

40x240 (100%)

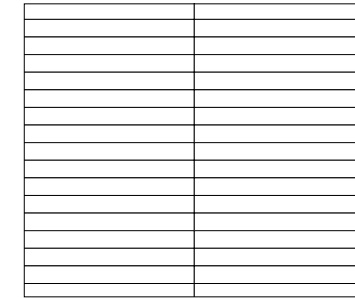

24x240 (100%)

### POSE SFALSATE | STAGGERED LAYING DESIGNS | POSES EN DÉCALÉ | VERSETZTE VERLEGUNG

Si raccomanda di sfalsare almeno di 1/3 rispetto alla lunghezza della lastra | The slabs should be staggered by at least one third of their length | Il est recommandé de poser le produit en le décalant d'au moins 1/3 de la longueur de la dalle | Es wird empfohlen, die Fliesen um mindestens 1/3 bezüglich der Länge der Fliese gegeneinander versetzt zu verlegen

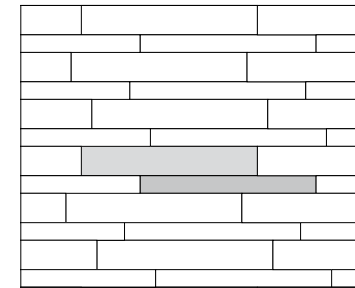

40x240 (62,5%)  
24x240 (37,5%)

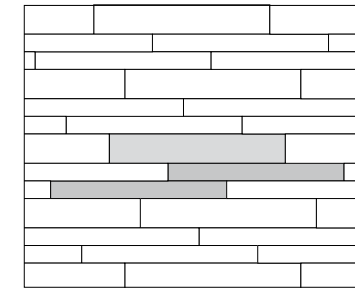

40x240 (45,45%)  
24x240 (54,55%)

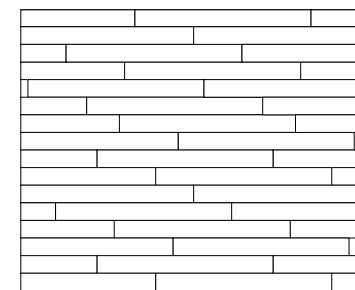

24x240 (100%)

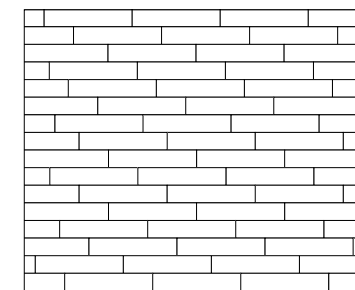

24x120 (100%)

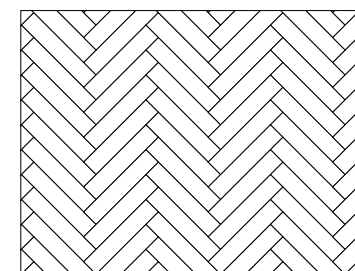

24x120 (100%)

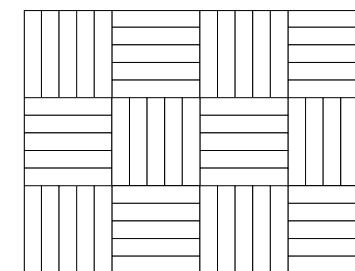

24x120 (100%)

495 KOMI\_WOOD\_EFFECT



# pezzi speciali

Special trims | Pièces spéciales | Formteile

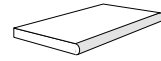

**2 cm**  
40x120x2 . 15,75"x47,24"x0,78"  
gradone toro lineare  
**KOM151** *Original*  
**KOM144** *Natural*  
**KOM137** *Traditional*

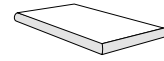

**2 cm**  
40x120x2 . 15,75"x47,24"x0,78"  
gradone toro angolare dx  
**KOM152** *Original*  
**KOM145** *Natural*  
**KOM138** *Traditional*

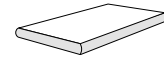

**2 cm**  
40x120x2 . 15,75"x47,24"x0,78"  
gradone toro angolare sx  
**KOM153** *Original*  
**KOM146** *Natural*  
**KOM139** *Traditional*

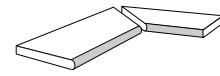

**2 cm**  
40x120x2 . 15,75"x47,24"x0,78"  
comp. gradone toro ang. interno  
**KOM154** *Original*  
**KOM147** *Natural*  
**KOM140** *Traditional*

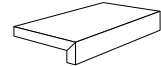

**2 cm**  
40x120x5 . 15,75"x47,24"x1,97"  
elemento L lineare  
**KOM155** *Original*  
**KOM148** *Natural*  
**KOM141** *Traditional*

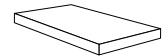

**2 cm**  
40x120x5 . 15,75"x47,24"x1,97"  
elemento L angolare dx  
**KOM156** *Original*  
**KOM149** *Natural*  
**KOM142** *Traditional*

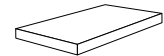

**2 cm**  
40x120x5 . 15,75"x47,24"x1,97"  
elemento L angolare sx  
**KOM157** *Original*  
**KOM150** *Natural*  
**KOM143** *Traditional*

## 2.0UT







Effetto Metallo  
Effet Métal  
Metall-Effekt

# metal effect

500 Acidic





# acidic

Lastre di ceramica in gres porcellanato - Gruppo Bla UGL  
Porcelain stoneware slabs - Gruppe Bla UGL  
Dalles en céramique en grès cérame - Group Bla UGL  
Keramikplatten aus Feinsteinzeug - Gruppe Bla UGL

### THICKNESS



6,5 mm  
SELF LEVELING

### SURFACES

Natural  
Rettificato | Rectified |  
Rectifié | Rektifiziert

### TECH INFO



BS EN 16165\_C >  
Dry & Wet rubber 4S:  
on request ≥ 36  
AS 4586 > P3: on request  
UNE-ENV 12633 >  
Class 2: on request



120x278\*  
47,24"x109,45"



120x120  
47,24"x47,24"

\* Lastre realizzate attraverso impasti colorati con colori standard | Slabs produced using coloured body mix available in standard shades

### COLORS

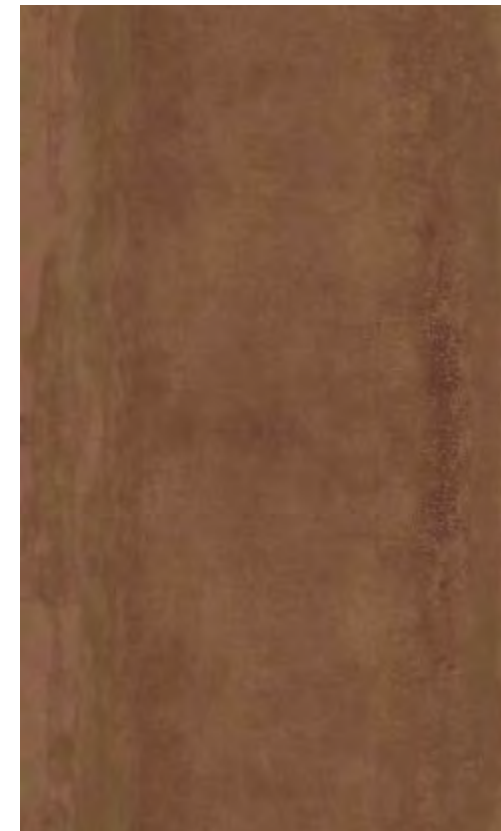

CORTEN



SILVER

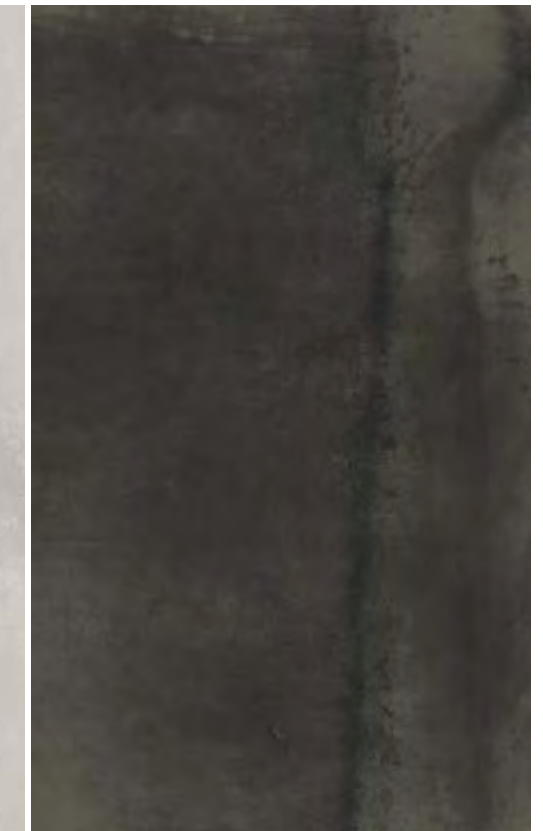

IRON



502 ACIDIC\_METAL EFFECT



IRON

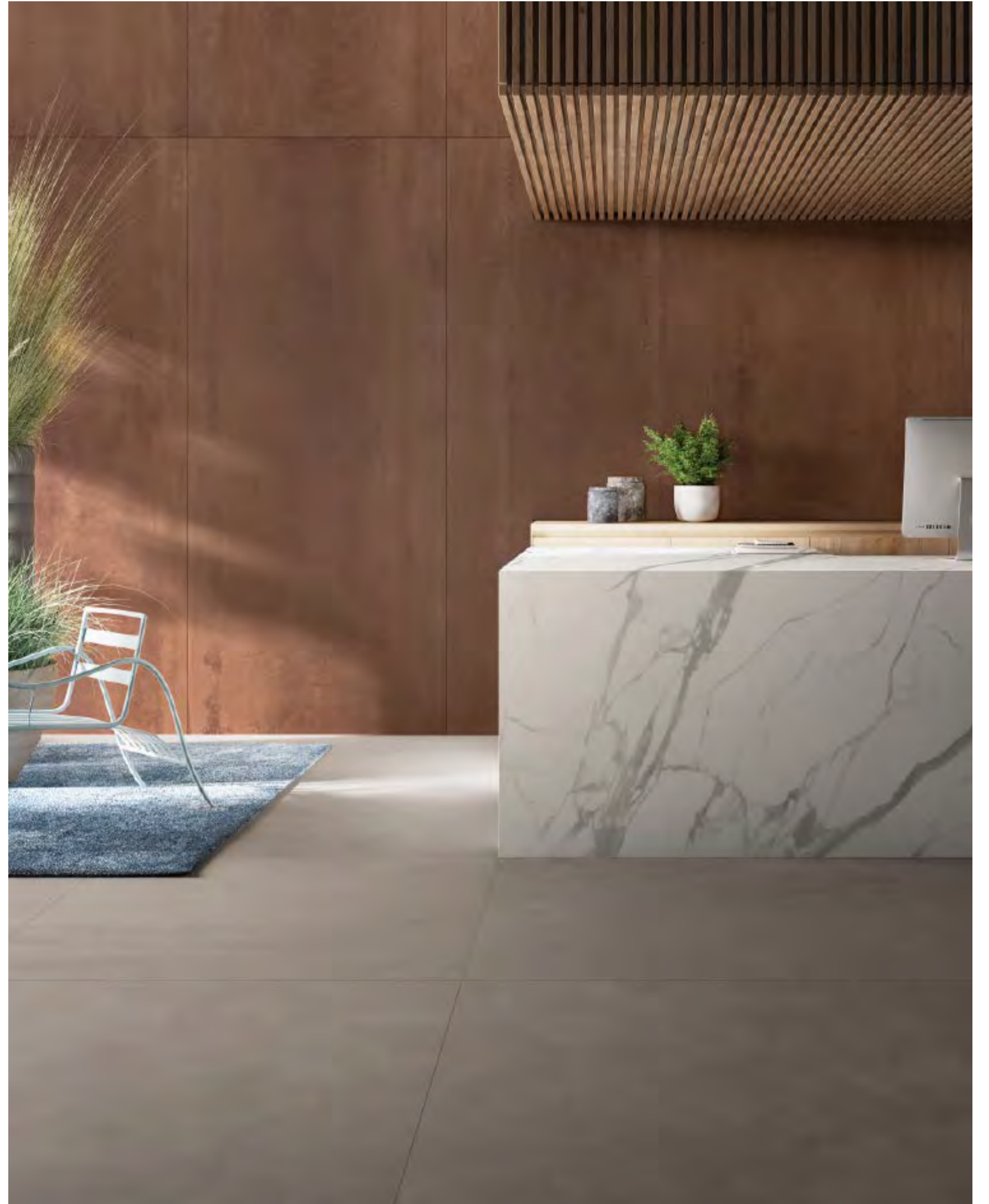

503 ACIDIC\_METAL EFFECT

CORTEN



504 ACIDIC\_METAL EFFECT



505 ACIDIC\_METAL EFFECT

SILVER



# acidic



## SIZES & SURFACES



**120x278\***  
47,24"x109,45"



**120x120**  
47,24"x47,24"

**Natural**  
Rettificato | Rectified |  
Rectifié | Rektifiziert

**6,5 mm**

**120x278** . 47,24"x109,45"  
**ACD099**

**120x120** . 47,24"x47,24"  
**ACD020**

CORTEN

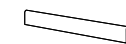

**6,5 mm**  
**8x120** . 3,15"x47,24"  
battiscopa  
**ACD021**

**Suggested grout**  
152 . Liquorice



## SIZES & SURFACES



**120x278\***  
47,24"x109,45"



**120x120**  
47,24"x47,24"

**Natural**  
Rettificato | Rectified |  
Rectifié | Rektifiziert

**6,5 mm**

**120x278** . 47,24"x109,45"  
**ACD101**

**120x120** . 47,24"x47,24"  
**ACD004**

IRON

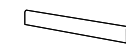

**6,5 mm**  
**8x120** . 3,15"x47,24"  
battiscopa  
**ACD018**

**Suggested grout**  
119 . London Grey





# acidic



508 - ACIDIC\_METAL\_EFFECT

## SIZES & SURFACES

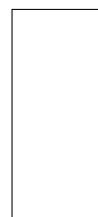

**120x278\***  
47,24"x109,45"



**120x120**  
47,24"x47,24"

**Natural**  
Rettificato | Rectified |  
Rectifié | Rektifiziert

**6,5 mm**

**120x278** . 47,24"x109,45"  
**ACD100**

**120x120** . 47,24"x47,24"  
**ACD024**

**SILVER**

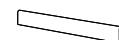

**6,5 mm**  
**8x120** . 3,15"x47,24"  
battiscopa  
**ACD027**

**Suggested grout**  
111 . Silver Grey



509 - ACIDIC\_METAL\_EFFECT





Effetto Puro  
Effet pur  
Reine Effekt

**pure  
effect**

512 Monochrome



# monochrome

Lastre di ceramica in gres porcellanato - Gruppo Bia UGL  
 Porcelain stoneware slabs - Gruppe Bia UGL  
 Dalles en céramique en grès cérame - Group Bia UGL  
 Keramikplatten aus Feinsteinzeug - Gruppe Bia UGL

## THICKNESS



6,5 mm  
 SELF LEVELING

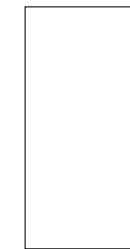

160x320\*  
 62,99"x125,98"

## SURFACES

Glossy / Natural  
 Rettificato | Rectified |  
 Rectifié | Rektifiziert

## TECH INFO

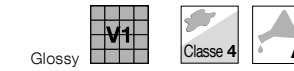

Glossy

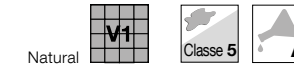

Natural



BS EN 16165\_C >  
 Dry & Wet rubber 4S:  
 on request ≥ 36  
 AS 4586 > P3: on request  
 UNE-ENV 12633 >  
 Class 2: on request

\* Lastre realizzate attraverso impasti tecnici colorati con colori dedicati | Slabs produced using coloured body mix with technical features available in dedicated shades

## COLORS

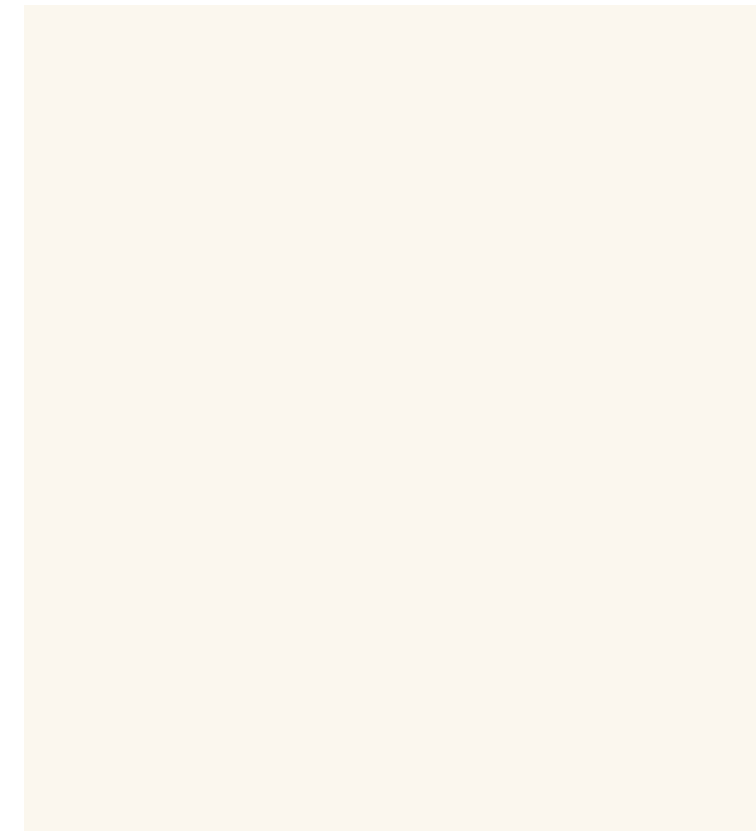

WHITE

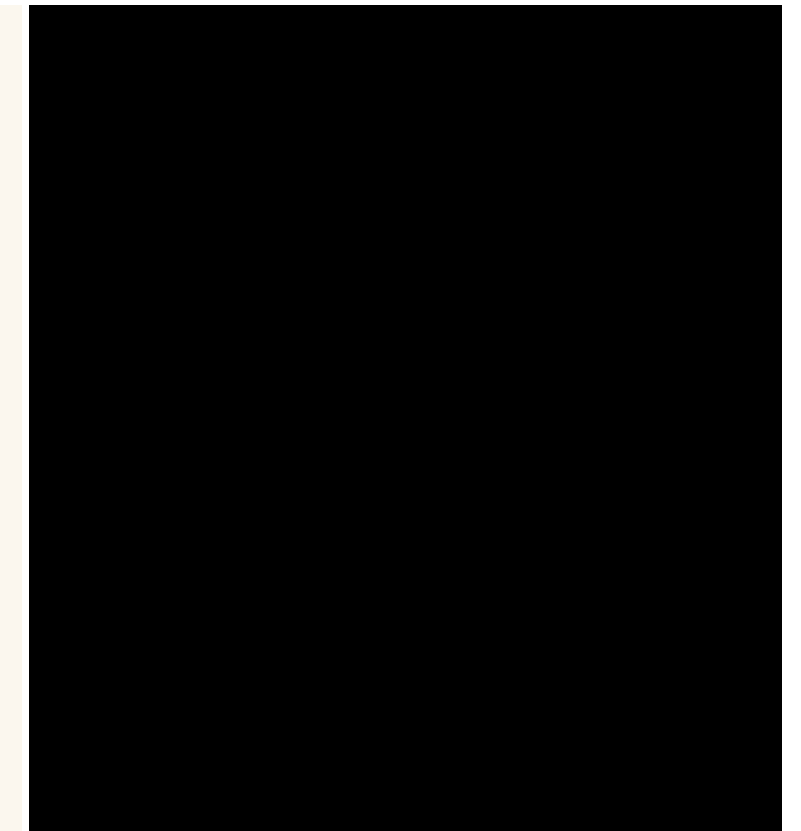

BLACK





514 MONOCHROME\_PURE EFFECT

515 MONOCHROME\_PURE EFFECT



# monochrome

516 MONOCHROME\_PURE EFFECT

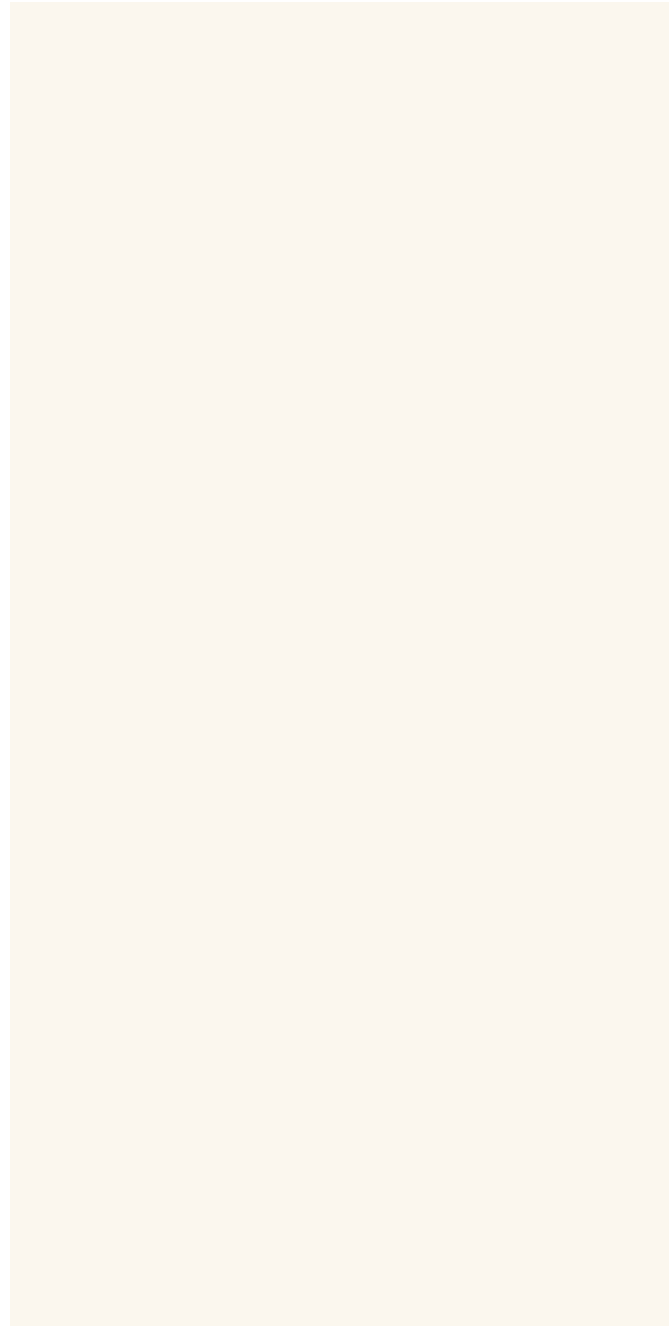

WHITE

## SIZES & SURFACES



160x320\*  
62,99"x125,98"

### 6,5 mm

**Glossy**  
Rettificato | Rectified |  
Rectifié | Rektifiziert

- 160x320 . 62,99"x125,98"  
**MNC004**

**Natural**  
Rettificato | Rectified |  
Rectifié | Rektifiziert

- 160x320 . 62,99"x125,98"  
**MNC005**

## critéri di 1° scelta | first class criteria | critères de premier choix | Kriterien für die 1. Wahl

### White Natural, Black Natural

Puntini a contrasto: fino a 5 puntini di dimensioni inferiori a 1 mm e posizionati lontani tra loro almeno 1,5 metri | Contrast spots: up to 5 spots less than 1mm in size and positioned at least 1.5 meters away from each other | Points contrastés : jusqu'à 5 points d'une taille inférieure à 1 mm et placés à une distance d'au moins 1,5 mètre les uns des autres | Kontrastpunkte: bis zu 5 Pünktchen mit einer Größe von weniger als 1 mm und einem Abstand von mindestens 1,5 m zueinander

Fori e spillature: fino a 3 buchi piccoli (si intende spillature di diametro inferiore a 0,3 mm) sparsi, quindi lontani fra loro almeno 1,5 metri | Holes and pin-holes: up to 3 small holes (meaning pin-holes with a diameter of less than 0.3 mm) scattered, therefore at least 1.5 meters away from each other | Trous et trous d'épingle: jusqu'à 3 petits trous (c'est-à-dire des trous d'épingle d'un diamètre inférieur à 0,3 mm) épars, c'est-à-dire espacés d'au moins 1,5 mètre | Löcher und Nadellöcher: bis zu 3 kleine verstreute Löcher (darunter werden Nadellöcher mit einem Durchmesser von weniger als 0,3 mm verstanden), daher mindestens 1,5 m voneinander entfernt

Fino a un solo foro di dimensioni inferiori a 1 mm | Up to a single hole less than 1mm in size | Jusqu'à un seul trou d'une taille inférieure à 1 mm | Bis zu einem einzelnen Loch mit einer Größe von weniger als 1 mm

### White Glossy

Assenza di graffi da mola, alonature da trattamento e segni di avanzamento | Absence of grindstone scratches, processing halos and feed marks | Absence de rayures réalisées par la meule, d'auroles dues au traitement et de signes d'avancement | Keine Kratzer durch Schleifsteine, Ränder durch Behandlung und Vorschubzeichen

Puntini a contrasto: fino a 5 puntini di dimensioni inferiori a 1 mm e posizionati lontani tra loro almeno 1,5 metri | Contrast spots: up to 5 spots less than 1mm in size and positioned at least 1.5 meters away from each other | Points contrastés : jusqu'à 5 points d'une taille inférieure à 1 mm et placés à une distance d'au moins 1,5 mètre les uns des autres | Kontrastpunkte: bis zu 5 Pünktchen mit einer Größe von weniger als 1 mm und einem Abstand von mindestens 1,5 m zueinander

Spillature: fino a due di dimensioni inferiori a 0,2 mm, sparse, quindi lontani fra loro almeno 1,5 metri | Pin-holes: up to two less than 0.2 mm in size, scattered, therefore at least 1.5 meters away from each other | Trous d'épingle: jusqu'à deux d'une taille inférieure à 0,2 mm, épars, c'est-à-dire espacés d'au moins 1,5 mètre | Nadellöcher: bis zu zwei verstreute Punkte mit einer Größe von weniger als 0,2 mm und daher mindestens 1,5 m voneinander entfernt

- Disponibile su richiesta | Available on request | Disponible sur demande | Auf Anfrage erhältlich

**Suggested grout**  
100 . White



## SIZES & SURFACES



160x320\*  
62,99"x125,98"

### 6,5 mm

**Natural**  
Rettificato | Rectified |  
Rectifié | Rektifiziert

- 160x320 . 62,99"x125,98"  
**MNC006**

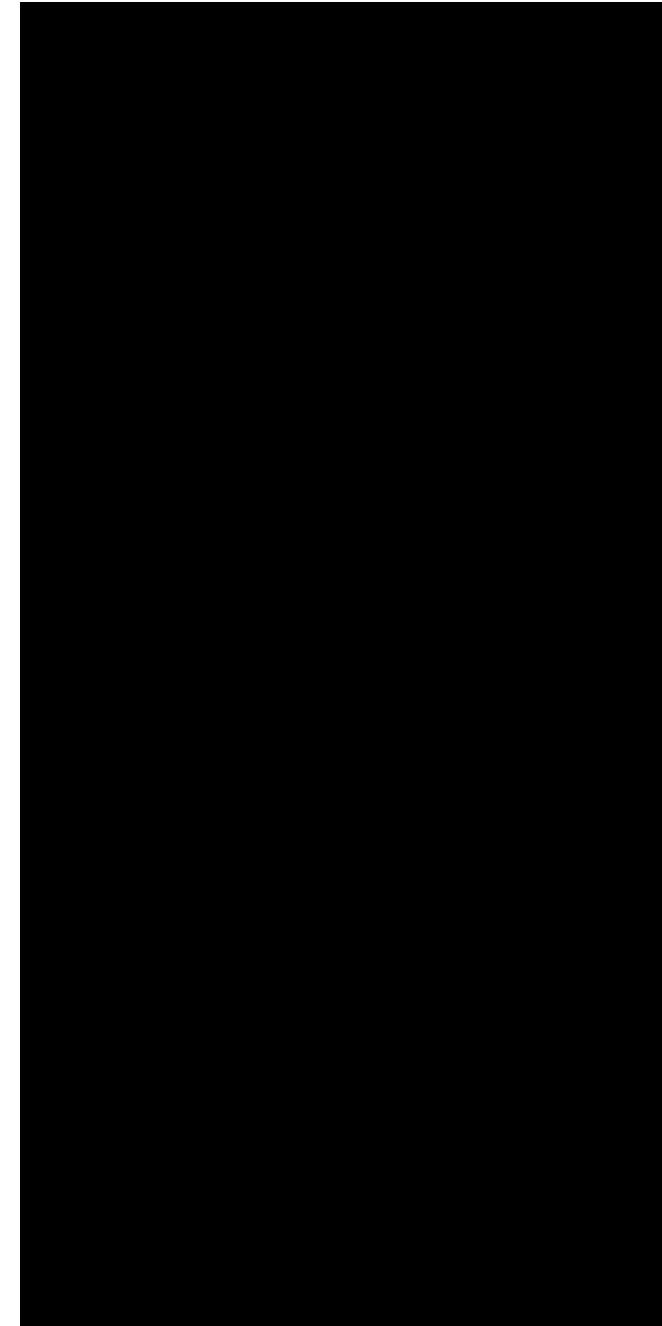

BLACK

- Disponibile su richiesta | Available on request | Disponible sur demande | Auf Anfrage erhältlich

**Suggested grout**  
120 . Black



517 MONOCHROME\_PURE EFFECT





518 THE COLLECTIONS\_TEXTURE EFFECT

Effetto Tessuto  
Effet Tissu  
Gewebe-Effekt

# textile effect

520 Dream

519 THE COLLECTIONS\_TEXTURE EFFECT



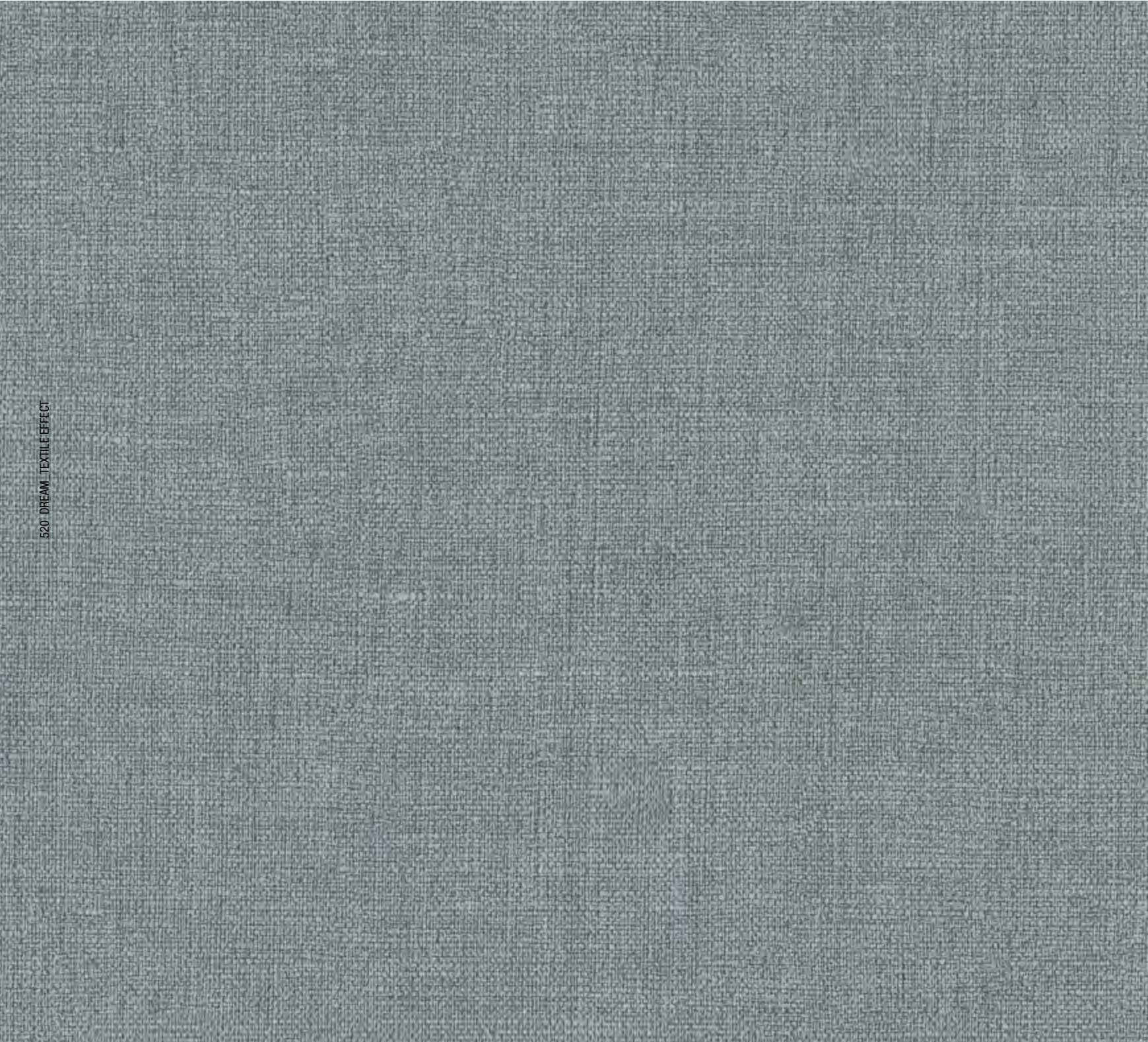

# dream

Lastre di ceramica in gres porcellanato - Gruppo Bla GL  
Porcelain stoneware slabs - Gruppe Bla GL  
Dalles en céramique en grès cérame - Group Bla GL  
Keramikplatten aus Feinsteinzeug - Gruppe Bla GL

### THICKNESS



6,5 mm  
SELF LEVELING

### SURFACES

**Natural**  
Rettificato | Rectified |  
Rectifié | Rektifiziert

### TECH INFO



BS EN 16165\_C >  
Dry & Wet rubber 4S: ≥ 36  
AS 4586 > P3  
UNE-ENV 12633 > Class 2

### DECORS

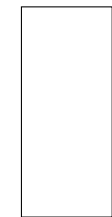

120x278\*  
47,24"X109,45"



ROMANTIC

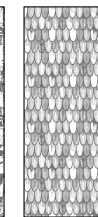

PEACOCK

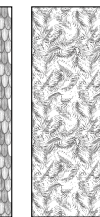

PLUME

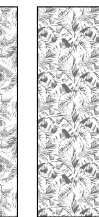

GLAM



CAMELLIA



BLOOM



GARDEN



LIGHT SIDE

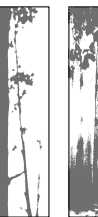

WOODS



JUNGLE

\* Lastre realizzate attraverso impasti colorati con colori standard | Slabs produced using coloured body mix available in standard shades

### COLORS



COTTON



SNOW

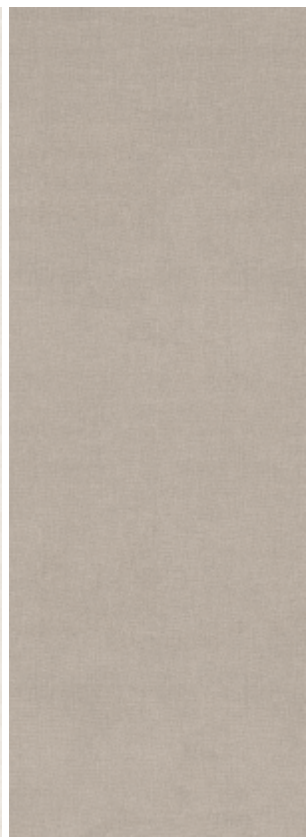

GROUND



NAVY BLUE



SAGE









524 DREAM TEXTILE EFFECT

525 DREAM TEXTILE EFFECT

















532 DREAM\_TEXTILE EFFECT

533 DREAM\_TEXTILE EFFECT





COTTON / NAVY BLUE



SAGE







# dream

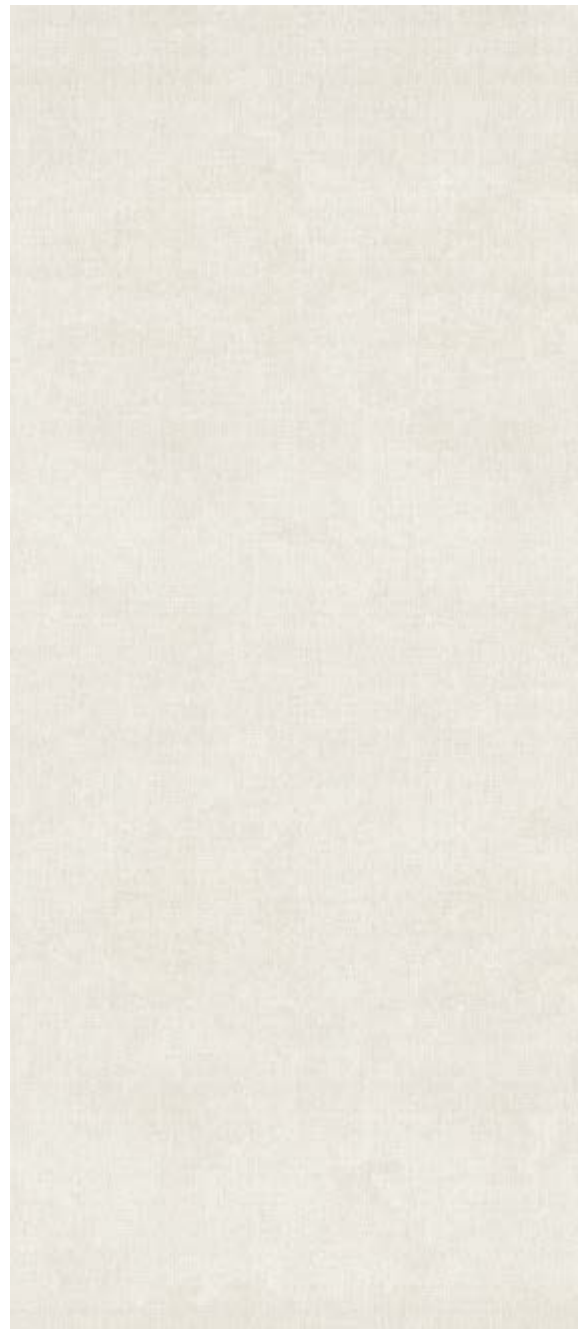

## SIZES & SURFACES

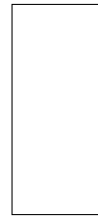

120x278\*  
47,24"x109,45"

**Natural**  
Rettificato | Rectified |  
Rectifié | Rektifiziert

**6,5 mm**

120x278 . 47,24"x109,45"  
**DRM095**

COTTON

538 DREAM\_TEXTILE EFFECT



## SIZES & SURFACES



120x278\*  
47,24"x109,45"

**Natural**  
Rettificato | Rectified |  
Rectifié | Rektifiziert

**6,5 mm**

120x278 . 47,24"x109,45"  
**DRM121**

SNOW

539 DREAM\_TEXTILE EFFECT

**Suggested grout**  
100 . White



**Suggested grout**  
100 . White





# dream

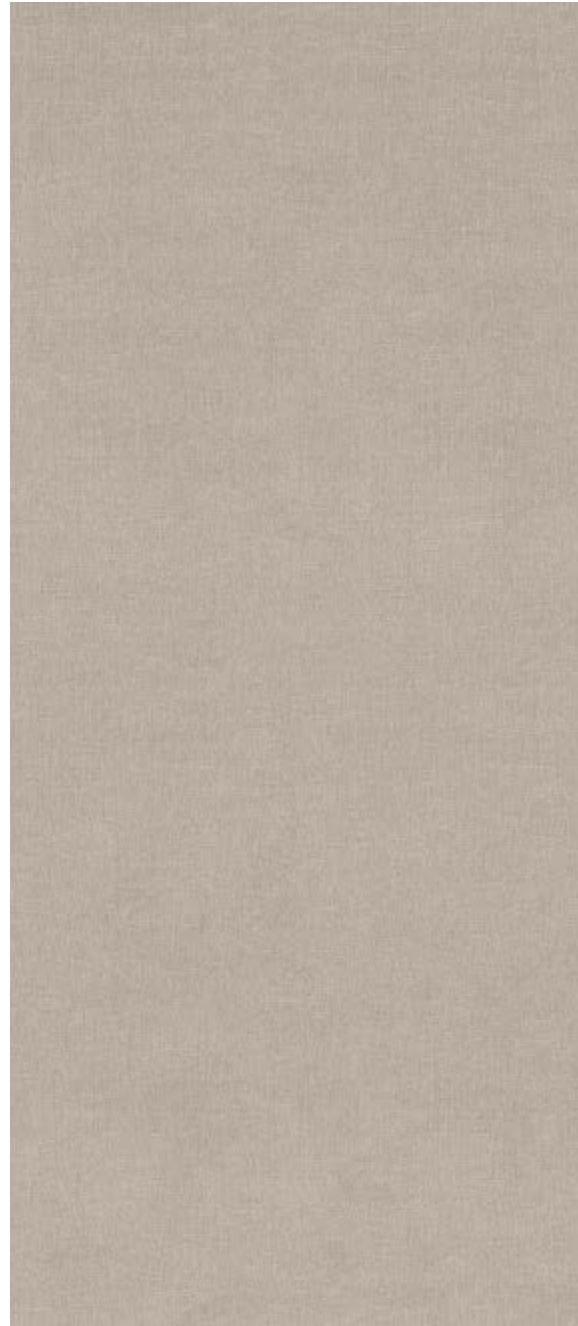

## SIZES & SURFACES



120x278\*  
47,24"x109,45"

**Natural**  
Rettificato | Rectified |  
Rectifié | Rektifiziert

**6,5 mm**

120x278 . 47,24"x109,45"  
**DRM123**

GROUND

**Suggested grout**  
111 . Silver Grey



## SIZES & SURFACES



120x278\*  
47,24"x109,45"

**Natural**  
Rettificato | Rectified |  
Rectifié | Rektifiziert

**6,5 mm**

120x278 . 47,24"x109,45"  
**DRM096**

NAVY BLUE

**Suggested grout**  
174 . Tornado





# dream

542 DREAM\_TEXTURE EFFECT



SAGE

## SIZES & SURFACES



120x278\*  
47,24"x109,45"

**Natural**  
Rettificato | Rectified |  
Rectifié | Rektifiziert

**6,5 mm**

**120x278** . 47,24"x109,45"  
**DRM097**

**Suggested grout**  
115 . River Grey



ROMANTIC

**6,5 mm**  
**120x278** . 47,24"x109,45"  
decoro  
**DRM179**

**Suggested grout**  
123 . Ancient White



PEACOCK

**6,5 mm**  
**120x278** . 47,24"x109,45"  
decoro  
**DRM177**

**Suggested grout**  
125 . Castle Grey



543 DREAM\_TEXTURE EFFECT



# dream

544 DREAM\_TEXTILE EFFECT



## PLUME

6,5 mm  
120x278 . 47,24"x109,45"  
decoro  
DRM127

Suggested grout  
110 . Manhattan 2000



## GLAM

6,5 mm  
120x278 . 47,24"x109,45"  
decoro  
DRM129

Suggested grout  
111 . Silver Grey



## CAMELLIA

6,5 mm  
120x278 . 47,24"x109,45"  
decoro  
DRM125

Suggested grout  
100 . White



545 DREAM\_TEXTILE EFFECT



# dream

546 DREAM\_TEXTILE EFFECT

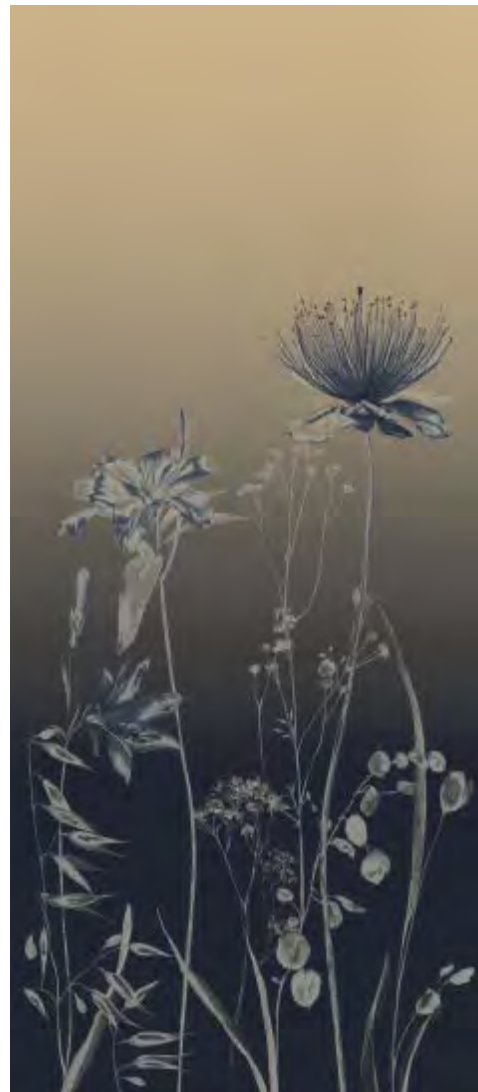

## BLOOM

6,5 mm  
120x278 . 47,24"x109,45"  
deco

DRM117

LAYING EXAMPLE

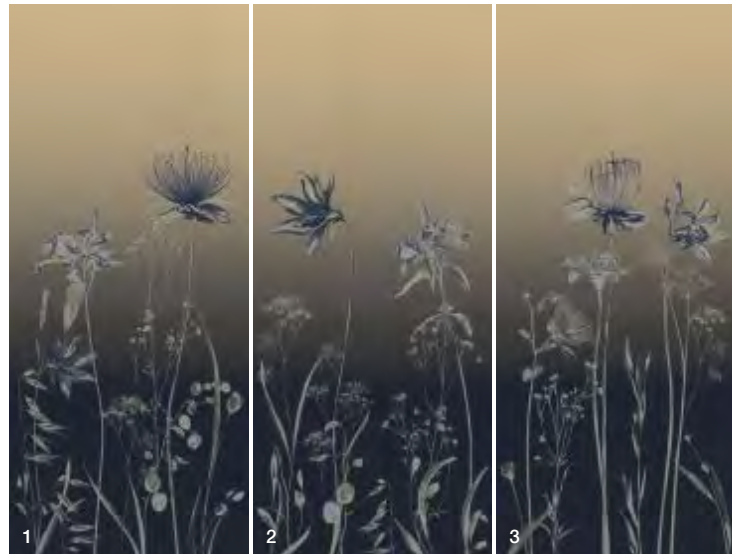

Prodotto con 3 diverse grafiche confezionate in modo casuale | Produced with 3 different graphic designs which are randomly combined and then packed | Produit avec 3 graphismes conditionnés de façon fortuite | Hergestellt mit 3 verschiedenen Graphiken, die zufällig zusammen verpackt werden

Suggested grout  
114 . Anthracite

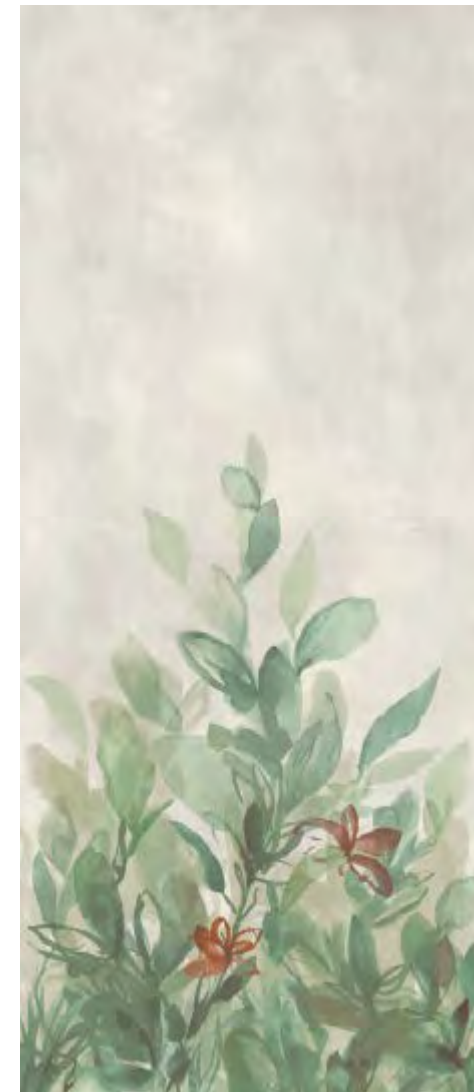

## GARDEN

6,5 mm  
120x278 . 47,24"x109,45"  
deco

DRM104

LAYING EXAMPLE



Prodotto con 3 diverse grafiche confezionate in modo casuale | Produced with 3 different graphic designs which are randomly combined and then packed | Produit avec 3 graphismes conditionnés de façon fortuite | Hergestellt mit 3 verschiedenen Graphiken, die zufällig zusammen verpackt werden

Suggested grout  
137 . Caribbean



547 DREAM\_TEXTILE EFFECT



# dream

548\_DREAM\_TEXTILE EFFECT



LAYING EXAMPLE



## LIGHT SIDE

6,5 mm  
120x278 . 47,24"x109,45"  
decoro

DRM102

Prodotto con 3 diverse grafiche confezionate in modo casuale | Produced with 3 different graphic designs which are randomly combined and then packed | Produit avec 3 graphismes conditionnés de façon fortuite | Hergestellt mit 3 verschiedenen Graphiken, die zufällig zusammen verpackt werden

Suggested grout  
103 . Moon White



LAYING EXAMPLE



## JUNGLE

6,5 mm  
120x278 . 47,24"x109,45"  
decoro

DRJ009

Prodotto con 3 diverse grafiche confezionate in modo casuale | Produced with 3 different graphic designs which are randomly combined and then packed | Produit avec 3 graphismes conditionnés de façon fortuite | Hergestellt mit 3 verschiedenen Graphiken, die zufällig zusammen verpackt werden

Suggested grout  
137 . Caribbean



549\_DREAM\_TEXTILE EFFECT



# dream



550 DREAM\_TEXTURE EFFECT

## LAYING EXAMPLE



### WOODS

6,5 mm  
120x278 . 47,24"x109,45"  
deco  
DRM099

Prodotto con 4 diverse grafiche confezionate in modo casuale | Produced with 4 different graphic designs which are randomly combined and then packed | Produit avec 4 graphismes conditionnés de façon fortuite | Hergestellt mit 4 verschiedenen Graphiken, die zufällig zusammen verpackt werden

Suggested grout  
110 . Manhattan 2000



551 DREAM\_TEXTURE EFFECT

WOODS





## wall collection

554 Brit





# brit

Piastrelle di ceramica in gres porcellanato - Gruppo Bla GL  
Porcelain stoneware tiles - Gruppe Bla GL  
Carreaux de céramique en grès céramee - Group Bla GL  
Keramikfliesen aus Feinsteinzeug - Gruppe Bla GL

### THICKNESS



9 mm

### SURFACES

Shiny

### TECH INFO



6x24,6  
2,36"x9,68"

### COLORS



WHITE

PEARL GREY

ALMOND

TOBACCO

MINT

OCEAN





556 BRIT\_WALL\_COLLECTION

557 BRIT\_WALL\_COLLECTION











# brit



WHITE

### SIZES & SURFACES

6x24,6  
2,36"x9,68"

Shiny

**9 mm**

6x24,6 . 2,36"x9,68"  
**BR1001**

Suggested grout  
103 . Moon White



TOBACCO

### SIZES & SURFACES

6x24,6  
2,36"x9,68"

Shiny

**9 mm**

6x24,6 . 2,36"x9,68"  
**BR1006**

Suggested grout  
136 . Mud



PEARL GREY

### SIZES & SURFACES

6x24,6  
2,36"x9,68"

Shiny

**9 mm**

6x24,6 . 2,36"x9,68"  
**BR1003**

Suggested grout  
110 . Manhattan 2000

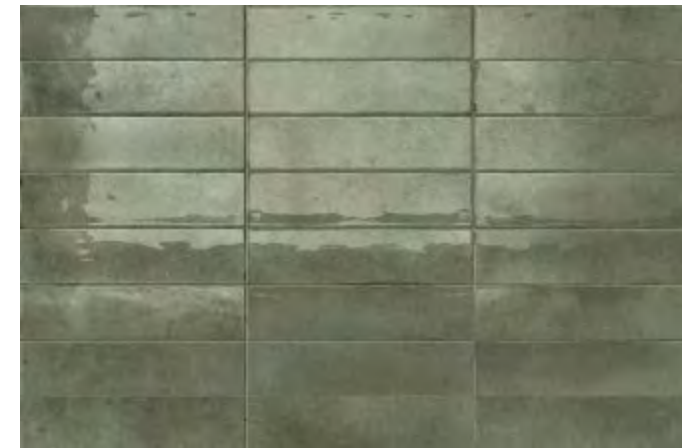

MINT

### SIZES & SURFACES

6x24,6  
2,36"x9,68"

Shiny

**9 mm**

6x24,6 . 2,36"x9,68"  
**BR1004**

Suggested grout  
113 . Cement Grey



ALMOND

### SIZES & SURFACES

6x24,6  
2,36"x9,68"

Shiny

**9 mm**

6x24,6 . 2,36"x9,68"  
**BR1002**

Suggested grout  
187 . Linen

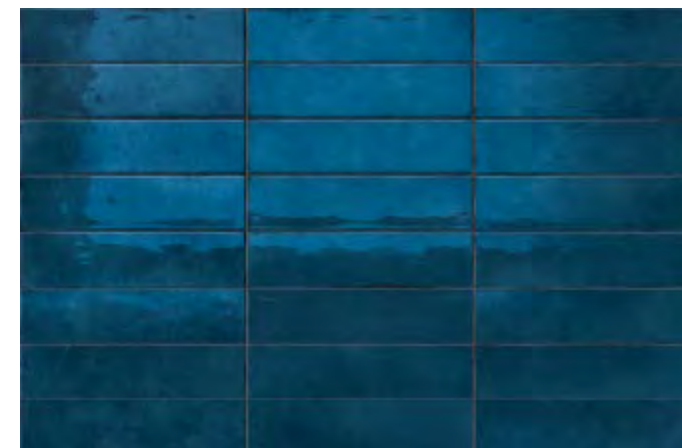

OCEAN

### SIZES & SURFACES

6x24,6  
2,36"x9,68"

Shiny

**9 mm**

6x24,6 . 2,36"x9,68"  
**BR1005**

Suggested grout  
169 . Steel Blue





# suggerimenti di posa

Laying suggestions | Conseils de pose | Empfehlungen zur Verlegung

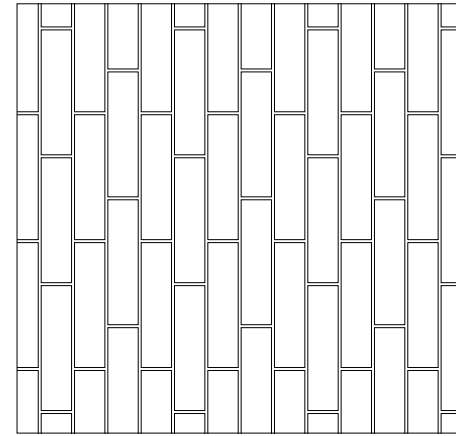
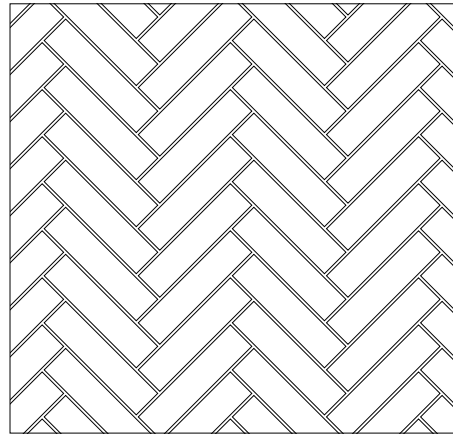
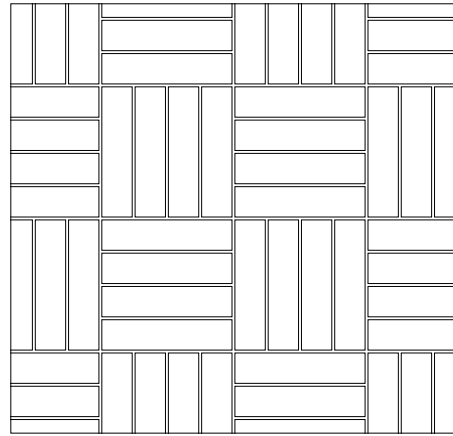
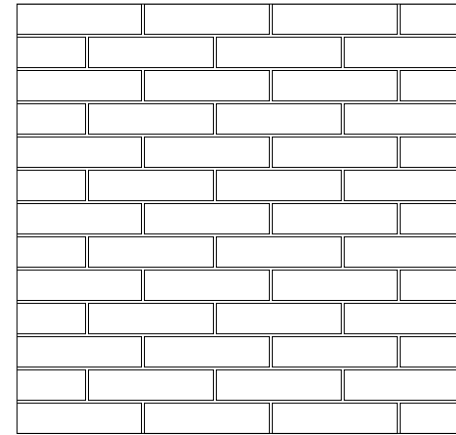
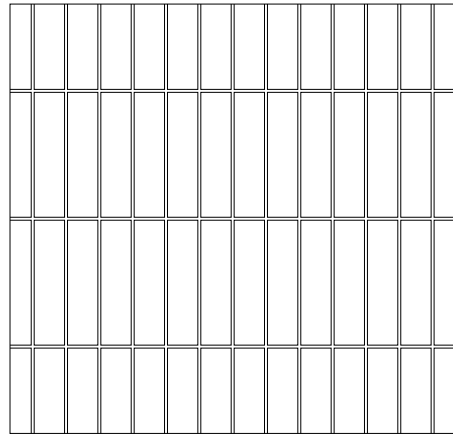
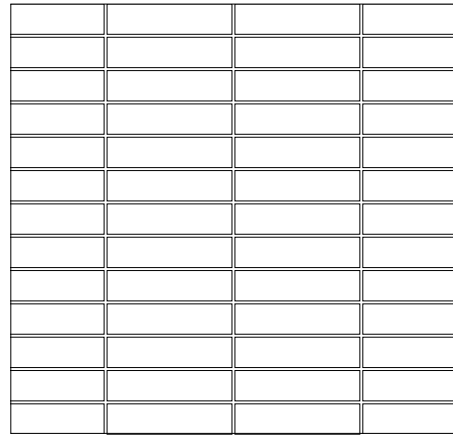

564 BRIT\_WALL COLLECTION



565 BRIT\_WALL COLLECTION



# tech info







# indice riassuntivo prodotti



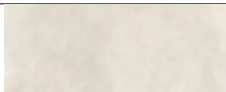

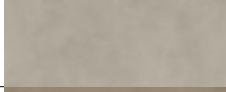
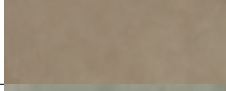

Product summary | Index récapitulatif des produits | Zusammenfassende Übersicht der Produkte

	120x278	120x120	60x120		100x100	80x80			40x80	
	6,5 mm	6,5 mm	6,5 mm	8,5 mm	2.0UT 2 cm	8,5 mm	10 mm**	2.0UT 2 cm	8,5 mm	10 mm**



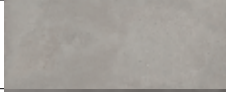

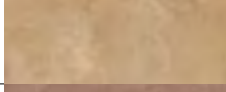
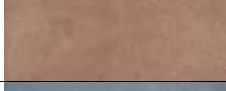
## homescape

SUGAR		●	●		●		●			
CLAY		●	●		●		●			
COAL		●	●		●		●			
CARAMEL		●	●		●		●			
MATCHA		●	●		●		●			

## pigmento

GIESSO		●	●	●			●	●	□	●	●
FANGO		●	●	●			●	●	□	●	●
POLVERE		●	●	●			●	●	□	●	●
CARBONE		●	●	●			●	●		●	●
ORO		●	●	●							
MATTONE		●	●	●							
OSSIDO		●	●	●							

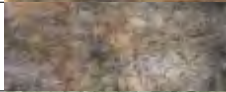
## urban craft



PLASTER		●	●	●					□		
REDCLAY		●	●	●							
CHARCOAL		●	●	●							
CHROME		●	●	●							

\* Disponibile su richiesta | Available on request | Disponible sur demande | Auf Anfrage erhältlich

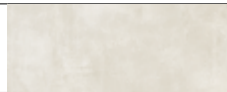
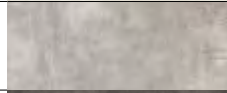
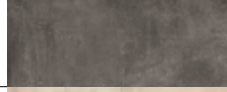
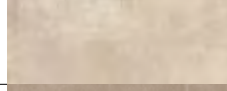

\*\* Disponibile fino ad esaurimento scorte | Available while stocks last | Disponible jusqu'à épuisement des stocks | Verfügbar solange der Vorrat reicht

	160x320*	120x278	120x120	60x120			80x80			40x80		60x60		30x60	
	6,5 mm	6,5 mm	6,5 mm	6,5 mm	8,5 mm	10 mm**	8,5 mm	10 mm**	2.0UT 2 cm	8,5 mm	10 mm**	8,5 mm	10 mm**	8,5 mm	10 mm**



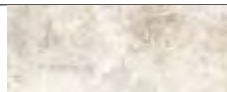

## portland

JORDAN		●	●	●	●	●	●	●	●	□	●	●			
HOOD		●	●	●	●	●	●	●	●	□	●	●	●	●	●
TABOR		●	●	●	●	●	●	●	●		●	●	●	●	●
HELEN			●	●	●			●	●		●	●	●	●	●
LASSEN			●	●	●			●	●	□	●	●	●	●	●

## action

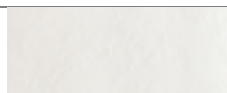
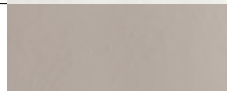
LIGHT			●	●	●										
DARK			●	●	●										

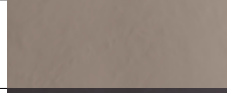
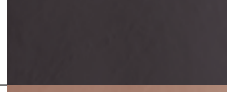
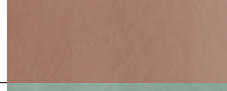
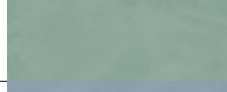
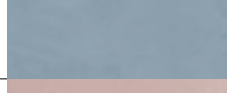
## res art

TALC			●	●	●										
ASH			●	●	●										
POWDER			●	●	●										
MUD			●	●	●										
LAVA			●	●	●										
POTTERY			●	●	●										
OLIVE			●	●	●										
AVIO			●	●	●										
CAMEO			●	●	●										

● natural ● real matt ★ glossy ☆ shiny ▲ honed □ grip outdoor ○ outdoor



# indice riassuntivo prodotti

Product summary | Index récapitulatif des produits | Zusammenfassende Übersicht der Produkte

	160x320*	120x278	60x120
	6,5 mm	6,5 mm	6,5 mm
<b>infinito 2.0</b>			
CARRARA C	* ▲	* ▲	*
STATUARIO EXTRA	* ▲	* ▲ ●	*
STATUARIO	* ▲	* ▲	*
LINCOLN	* ▲	* ▲	*
CALACATTA WHITE	* ▲	* ▲	*
ELEGANT WHITE	●		
CALACATTA LIGHT	* ▲	* ▲	*
CALACATTA GOLD	* ▲	* ▲ ●	*
CAPRAIA	* ▲	* ▲ ●	*
SUPER WHITE		* ●	*
ONICE WHITE	*	*	*
PATAGONIA		*	
TAJ MAHAL		*	
BRECCIA VAN GOGH		*	
CALACATTA VIOLA		*	

	160x320*	120x278	60x120
	6,5 mm	6,5 mm	6,5 mm
<b>infinito 2.0</b>			
CALACATTA MACCHIA VECCHIA	●	*	
GOLD RIVER		*	
ROYAL CREAMY		●	
FIOR DI BOSCO	* ▲	* ▲ ●	*
AMAZZONITE		*	
EMERALD GREEN		*	
RIVER JADE		*	
WHITE BEAUTY		*	
GREEN DENIS		*	
SODALITE BLUE		*	
SAHARA NOIR	* ▲	* ▲	*
PORT LAURENT		*	*
PIETRA GREY		●	
OMBRA DI CARAVAGGIO	* ▲	* ▲	*

570 TECH INFO

571 TECH INFO

\* Disponibile su richiesta | Available on request | Disponible sur demande | Auf Anfrage erhältlich

\*\* Disponibile fino ad esaurimento scorte | Available while stocks last | Disponible jusqu'à épuisement des stocks | Verfügbar solange der Vorrat reicht

● natural ● real matt \* glossy ☆ shiny ▲ honed □ grip outdoor ○ outdoor











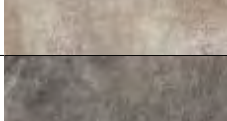

# indice riassuntivo prodotti

Product summary | Index récapitulatif des produits | Zusammenfassende Übersicht der Produkte

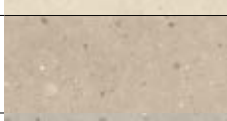
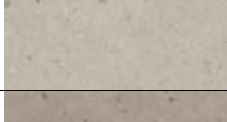
	160x320*	120x278	120x120	60x120	100x100	80x80
	6,5 mm	6,5 mm	6,5 mm	8,5 mm	2.0UT 2 cm	8,5 mm
<b>background</b>						
SNOWY		●	●	●		●
CREAM		●	●	●		●
CLOUD		●	●	●		●
CAVIAR		●	●	●		●
<b>royal travertino</b>						
EBUR VEIN		●		●		
EBUR CROSS				●		●
NAVONA VEIN		●		●		
NAVONA CROSS				●		●
GRISEO VEIN		●		●		
GRISEO CROSS				●		●
<b>stone lab</b>						
SILVER STONE		●				
CEPPO					□	

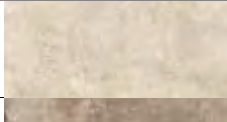
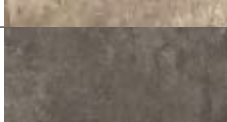
\* Disponibile su richiesta | Available on request | Disponible sur demande | Auf Anfrage erhältlich

\*\* Disponibile fino ad esaurimento scorte | Available while stocks last | Disponible jusqu'à épuisement des stocks | Verfügbar solange der Vorrat reicht

	160x320*	120x278	120x120	60x120		100x100	80x80		40x80	
	6,5 mm	6,5 mm	6,5 mm	8,5 mm	10 mm**	2.0UT 2 cm	8,5 mm	10 mm**	8,5 mm	10 mm**
<b>upper</b>										
BUTTER		●	●	●						
FOG		●	●	●		□				
DOVE GREY		●	●	●						
ELEPHANT GREY		●	●	●						
<b>keynote</b>										
PEARL		●	●	●	●		●	●	●	●
AMBER		●	●	●	●		●	●	●	●
ARCTIC		●	●	●	●		●	●	●	●
COOL GREY		●	●	●	●		●	●	●	●
<b>reframe</b>										
IVORY		●	●	●	●		●	●	●	●
TAUPE		●	●	●	●		●	●	●	●
GRAPHITE		●	●	●	●		●	●	●	●
<b>shards</b>										
LARGE WHITE				★ ●						
LARGE GREY				★ ●						
LARGE BLACK				★ ●						

● natural ● real matt ★ glossy ☆ shiny ▲ honed □ grip outdoor ○ outdoor



# indice riassuntivo prodotti

Product summary | Index récapitulatif des produits | Zusammenfassende Übersicht der Produkte

	120x278	120x120	60x120		30x120		20x120		80x80		60x60		30x60		6x24,6	
	6,5 mm	6,5 mm	8,5 mm	10 mm**	8,5 mm	10 mm**	8,5 mm	10 mm**	8,5 mm	10 mm**	2.OUT 2 cm	8,5 mm	10 mm**	8,5 mm	10 mm**	9 mm

## planeto

VENUS		●	●	●	●	●	●	●	●	●	●	□	●	●	●	●	
MOON		●	●	●	●	●	●	●	●	●	●	□	●	●	●	●	
MARS		●	●	●	●	●	●	●	●	●	●	□	●	●	●	●	
JUPITER		●	●	●	●	●	●	●	●	●	●	□	●	●	●	●	
PLUTO		●	●	●	●	●	●	●	●	●	●		●	●	●	●	

## acidic

CORTEN		●	●														
IRON		●	●														
SILVER		●	●														

## brit

WHITE																	☆
PEARL GREY																	☆
ALMOND																	☆
TOBACCO																	☆
MINT																	☆
OCEAN																	☆

\* Disponibile su richiesta | Available on request | Disponible sur demande | Auf Anfrage erhältlich  
 \*\* Disponibile fino ad esaurimento scorte | Available while stocks last | Disponible jusqu'à épuisement des stocks | Verfügbar solange der Vorrat reicht

	160x320*	120x278	40x240	24x240	24x120	40x120
	6,5 mm	6,5 mm	6,5 mm	6,5 mm	6,5 mm	2.OUT 2 cm

## woodblock

BRAVE OAK				●	●	●	
BRAVE STRIPY OAK			●				
BALANCE OAK				●	●	●	
BALANCE GROOVE OAK			●				
SCRATCH OAK				●	●	●	

## komi

ORIGINAL				●	●	●	□
NATURAL				●	●	●	□
TRADITIONAL				●	●	●	□
ELEGANT				●	●	●	
CLASSIC				●	●	●	
LODGE			●				

## monochrome







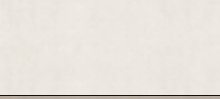
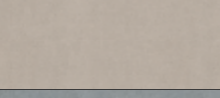
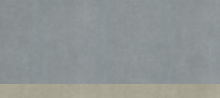
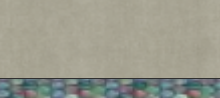

WHITE		★					
BLACK		●					

● natural ● real matt ★ glossy ☆ shiny ▲ honed □ grip outdoor ○ outdoor

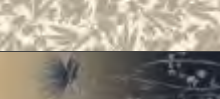

# indice riassuntivo prodotti

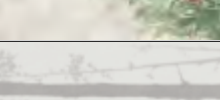
Product summary | Index récapitulatif des produits | Zusammenfassende Übersicht der Produkte

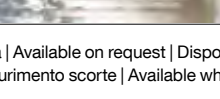
	120x278	
	6,5 mm	
<b>dream</b>		
COTTON		●
SNOW		●
GROUND		●
NAVY BLUE		●
SAGE		●
PEACOCK		●
ROMANTIC		●
PLUME		●
GLAM		●
CAMELLIA		●
BLOOM		●
GARDEN		●
LIGHT SIDE		●
JUNGLE		●
WOODS		●

\* Disponibile su richiesta | Available on request | Disponible sur demande | Auf Anfrage erhältlich

\*\* Disponibile fino ad esaurimento scorte | Available while stocks last | Disponible jusqu'à épuisement des stocks | Verfügbar solange der Vorrat reicht

● natural ● real matt ★ glossy ☆ shiny ▲ honed □ grip outdoor ○ outdoor

# superfici

Surfaces | Surfaces | Oberflächen

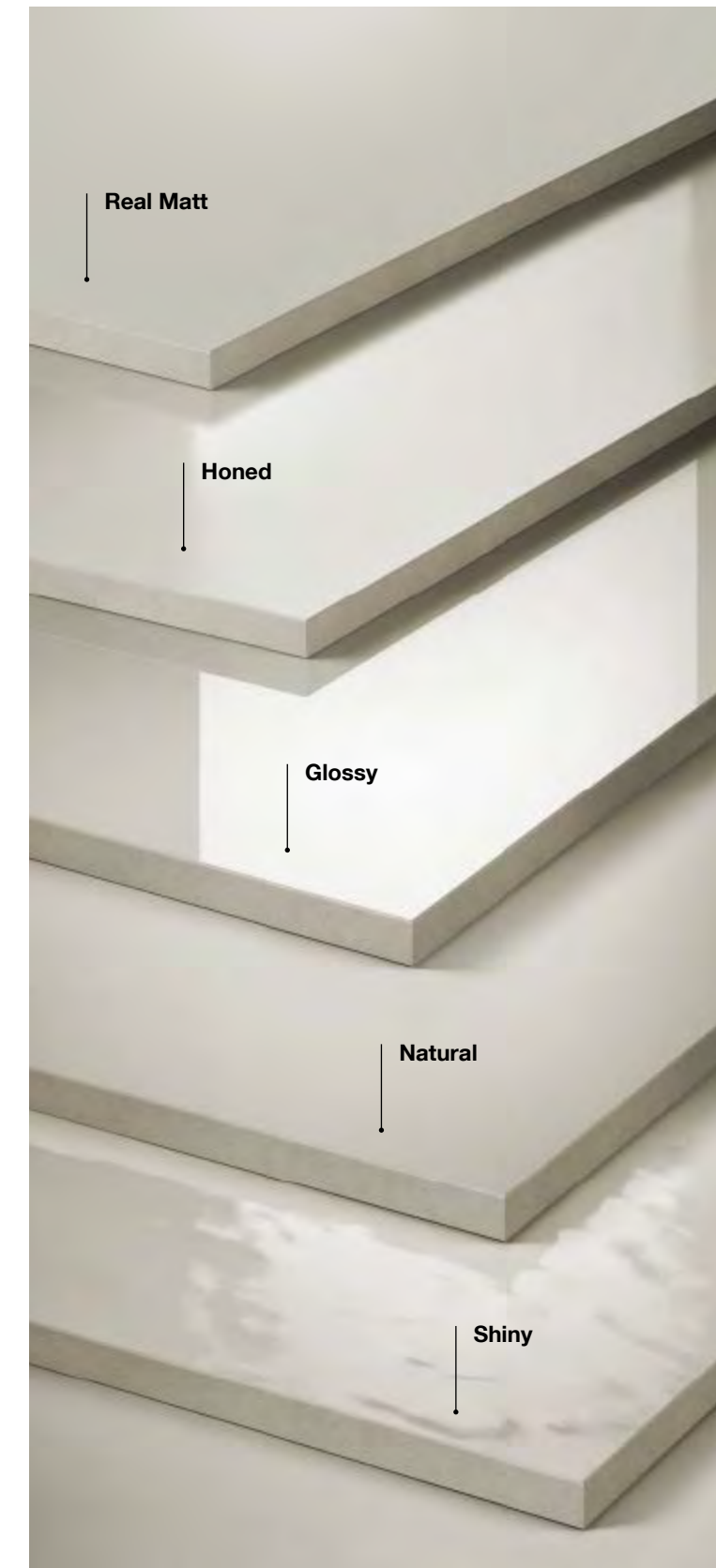

## Real Matt

La tecnologia Real Matt regala al gres porcellanato una finitura estremamente matt e molto più opaca rispetto alla finitura Naturale, garantendo massima morbidezza al tatto, facilità di pulizia. | Real Matt technology lends porcelain stoneware a highly matt finish (much more so than the unworked finish), guaranteeing maximum softness to the touch and ease of cleaning. | La technologie Real Matt donne au grès cérame une finition extrêmement mate et beaucoup plus opaque que la finition Naturel, garantissant une douceur extrême au toucher et facilitant le nettoyage. | Die Technologie Real Matt verleiht dem Feinsteinzeug ein extrem mattes Finish und ist wesentlich opaker als das naturelle Finish, was eine maximale taktile Geschmeidigkeit und eine einfache Reinigung garantiert.

## Honed

La superficie HONED è una finitura di nuova concezione che risulta più opaca rispetto alla versione POLISHED. Le differenze di lucentezza ed eventuali disomogeneità di aspetto sono quindi da considerare caratteristiche intrinseche di questa superficie. | The HONED surface is a new finish that gives a more matt effect than the POLISHED version. Any differences in shine and appearance are therefore a natural feature of this surface finish. | La surface HONED est un nouveau concept de finition qui est plus mat que la version POLISHED. Les différences de brillance et l'éventuel aspect non homogène doivent donc être considérés comme des caractéristiques intrinsèques de cette surface. | Die Oberfläche HONED (Geschliffen) ist ein neues Konzept, das matter erscheint als die Version POLISHED (Poliert). Die Unterschiede im Glanz und alle eventuellen Ungleichmäßigkeiten im Aussehen sind daher als charakteristische Eigenschaften dieser Oberfläche anzusehen.

## Glossy

Una superficie liscia e piacevole al tatto, ottenuta grazie alla combinazione di mole diamantate a granulometria decrescente che concorrono a creare un effetto suggestivo, dal caratteristico riflesso semi lucido. | A smooth surface that is pleasing to the touch, produced using a combination of diamond wheels with decreasing grain size to create a stunning and distinctive semi-gloss finish. | Une surface lisse et agréable au toucher, obtenue grâce à la combinaison de meules diamantées à granulométrie décroissante qui contribuent à créer un effet saisissant, avec un reflet semi-brillant caractéristique. | Eine glatte und angenehme zu berührende Oberfläche, die dank der Kombination von Diamant-Schleifscheiben mit abnehmender Korngröße erzielt wird, die zusammen einen eindrucksvollen Effekt mit einer typischen seidenmatten Reflexion erzeugen.

## Natural

La finitura NATURAL risulta opaca e materica al tatto, particolarmente indicata per esaltare effetti di profondità su superfici dai cromatismi delicati. Il leggero effetto di patinatura restituisce una piacevole sensazione di morbidezza. | The NATURAL finish is matt, textured, and particularly suitable for enhancing depth effects on materials with subtle shades. The light sheen lends the tile a pleasant softness to the touch. | La finition NATURELLE est mate et texturée au toucher, particulièrement indiquée pour renforcer les effets de profondeur sur les surfaces aux couleurs délicates. Le léger effet de couchage restitue une agréable sensation de douceur. | Die Oberfläche NATURAL (Naturell) ist opak und fühlt sich materiell an, sie ist besonders zur Verbesserung der Tiefeneffekte auf Oberflächen mit zarten Farben geeignet. Der leichte Beschichtungseffekt sorgt für ein angenehmes Weichheitsgefühl.

## Shiny

La superficie tattile e densa di smalto della collezione Brit è il risultato di un'innovazione tecnologica e di una selezione di materie prime che regalano lucentezza e brillantezza, riproducendo l'estetica imperfetta della ceramica fatta a mano. | The tactile, enamel-rich surface of the Brit collection is the result of technological innovation and a selection of raw materials that brings brightness and shine, reproducing the charming imperfections of handmade ceramics. | La surface tactile et riche en émail de la collection Brit est le résultat d'une innovation technologique et d'une sélection de matières premières qui apportent brillance et éclat, reproduisant l'esthétique imparfaite des céramiques faites à la main. | Die fühlbare und dichte Oberfläche der Glasur bei der Kollektion Brit ist das Ergebnis einer technologischen Innovation und einer Auswahl an Rohstoffen, die Helligkeit und Glanz verleihen sowie die unvollkommene Ästhetik handgefertigter Keramik nachbilden.



# guida alla consultazione

Recommendation Guidelines | Conseil D'utilisation | Technischer Informationsfuehrer

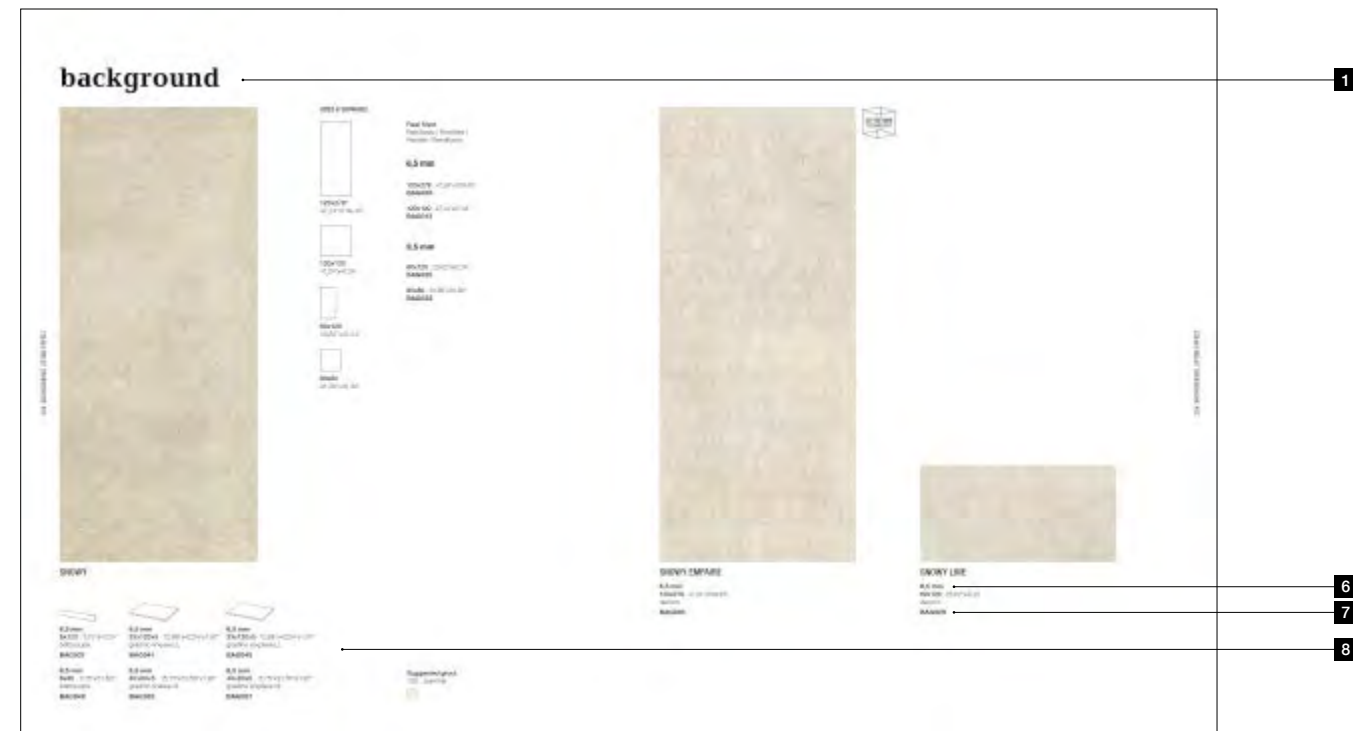
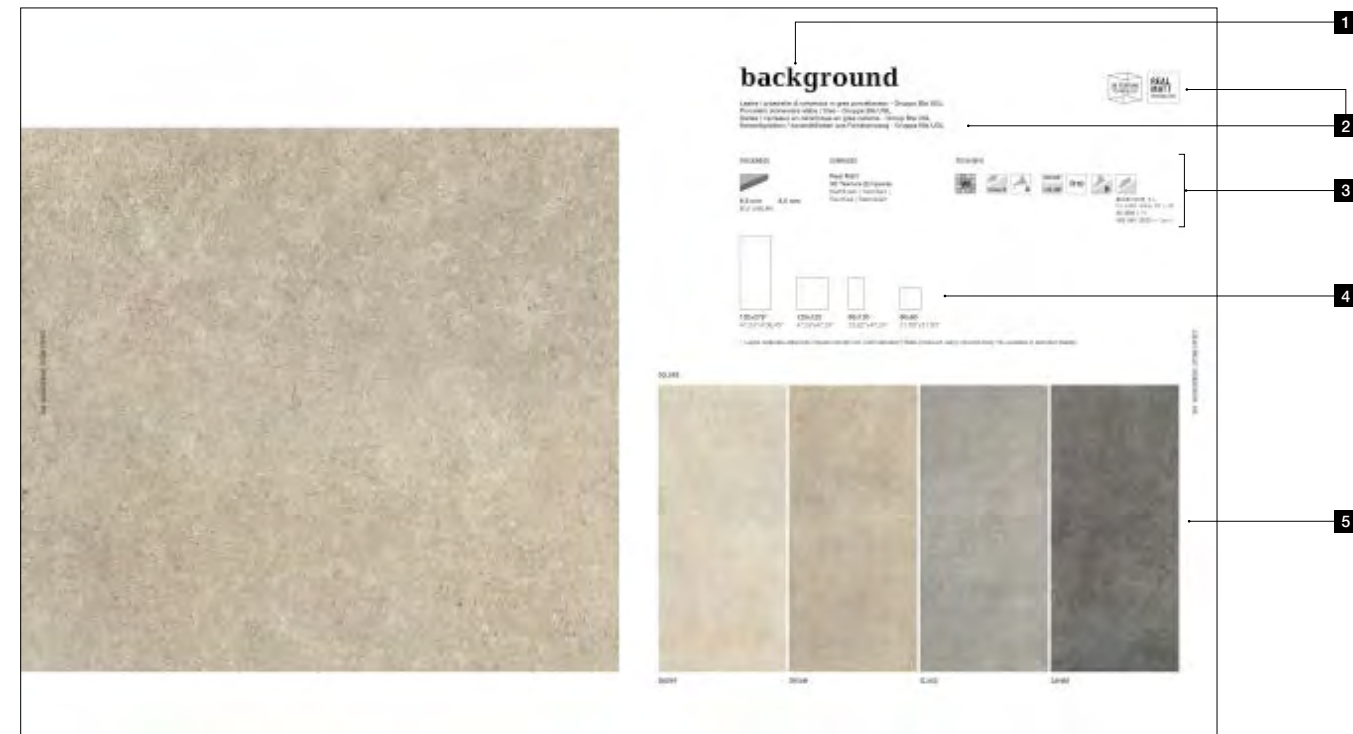

- 1** Nome collezione  
Name of collection  
Nom collection  
Name der Kollektion
- 2** Tecnologia  
Technologie  
Technologie
- 3** Caratteristiche tecniche  
Technical characteristics  
Caractéristiques techniques  
Technische daten
- 4** Formati\*  
Sizes\*  
Formats\*  
Formate\*
- 5** Tacche colore  
Colour samples  
Couleurs disponibles  
Farbmuster
- 6** Spessore  
Thickness  
Épaisseur  
Dicke
- 7** Codice prodotto  
Product code  
Code produit  
Artikelnummer
- 8** Pezzi speciali  
Trims  
Pièces Spéciales  
Formstücke

\* I formati dei prodotti indicati sono "nominali" e non reali | The sizes of the products stated are "nominal sizes", i.e. they may not match the actual dimensions of the product | Les formats des produits indiqués sont "nominaux" et non réels | die angegebenen Formate der Produkte sind "Richtwerte" und nicht reell

# simbologia

Symbols | Symbologie | Symbologie

## variazione di stonalizzazione

Color/shade variation guideline | Effets nuancés possibles |  
Brandfarben Mischungstabelle



Aspetto uniforme  
Uniform appearance  
Aspect uniforme  
Einheitliches Aussehen



Lieve variazione  
Slight variations  
Légère variation  
Geringe Abweichung



Moderata variazione  
Moderate variations  
Variation modérée  
Mässige Abweichung



Forte stonalizzazione  
Substantial variations  
Effet dénuancé très accentué  
Starke Abweichung

## spessore

Thickness | Épaisseur | Dicke



## resistenza allo scivolamento

Skid resistance | Résistance au glissement | Rutschhemmung



DIN EN 16165\_B

## scivolosità sul bagnato

Anti-slip index on wet surfaces | Coefficient anti-dérapage sur surfaces mouillées |  
Glätte auf nasser Oberfläche



DIN EN 16165\_A

## pendulum

Coefficiente dinamico di attrito | Coefficient de frottement dynamique |  
Dynamische Reibungszahl



BS EN 16165\_C >  
Dry & Wet rubber 4S: ≥ 36  
AS 4586 > P3  
UNE-ENV 12633 > Class 2



BS EN 16165\_C >  
Dry & Wet rubber 4S:  
on request ≥ 36  
AS 4586 > P3: on request  
UNE-ENV 12633 >  
Class 2: on request

## resistenza alle macchie

Stain resistance | Resistance aux taches | Fleckenbeständigkeit



UNI EN 14411-G  
ISO 10545-14

## resistenza all'attacco chimico

Chemical resistance | Resistance a l'attaque chimique |  
Beständigkeit gegen chemikalien



UNI EN 14411-G  
ISO 10545-13

## DCOF (dynamic coefficient of friction)

Coefficiente dinamico di attrito | Coefficient de frottement dynamique |  
Dynamische Reibungszahl



ANSI A 137.1:2012



# pezzi speciali

Trims | Pièces spéciales | Spezialteile

## thickness



### battiscopa a becco decorato in tono 8x120 (5x120 Komi)

Skirting with decorated upper edge in matching shade | Plinthe à bec décoration assortie | Sockelleiste mit Eckabrundung, farblich passend dekoriert



### gradino lineare "LL" tagliato dal fondo e assemblato 33x120x5

"LL" linear step cut from the base tile and assembled | Marche linéaire "LL" coupée depuis le fond et assemblée | Gerade Stufe "LL", aus dem Boden geschnitten und zusammengesetzt

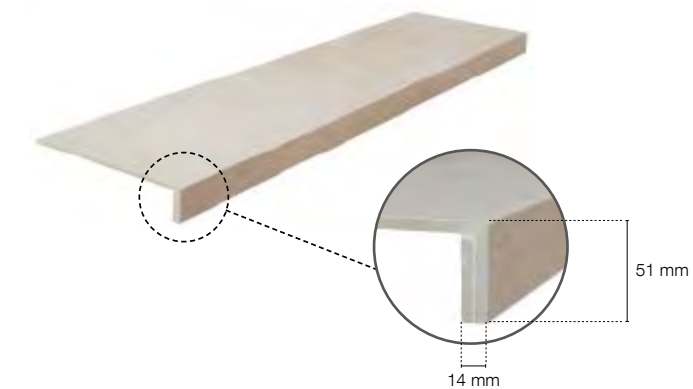

### gradino angolare "LL" tagliato dal fondo e assemblato 33x120x5

"LL" corner step cut from the base tile and assembled | Marche angulaire "LL" coupée depuis le fond et assemblée | Eckstufe "LL", aus dem Boden geschnitten und zusammengesetzt

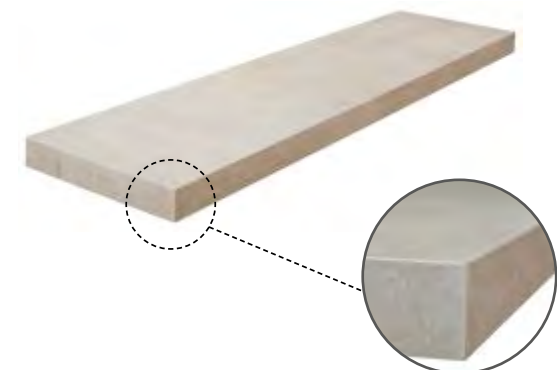

## thickness



### battiscopa a becco decorato in tono 8x80 (8x60 Portland e Planeto - 8x120 Planeto)

Skirting with decorated upper edge in matching shade | Plinthe à bec décoration assortie | Sockelleiste mit Eckabrundung, farblich passend dekoriert



### gradino lineare "M" tagliato dal fondo e assemblato 40x80x5 (33x120x5 Planeto)

"M" linear step cut from the base tile and assembled | Marche linéaire "M" coupée depuis le fond et assemblée | Gerade Stufe "M", aus dem Boden geschnitten und zusammengesetzt

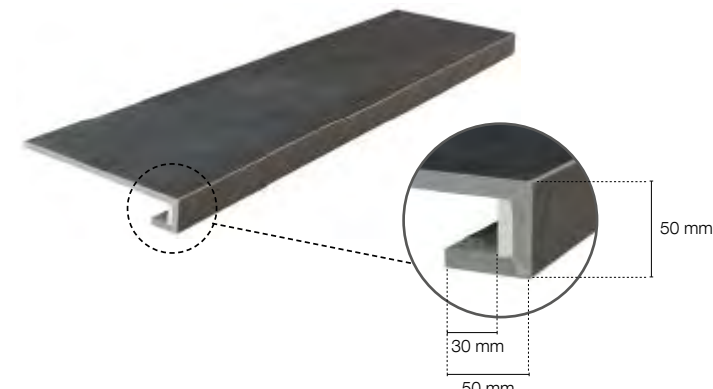

### gradino angolare "M" tagliato dal fondo e assemblato 40x80x5 (33x120x5 Planeto)

"M" corner step cut from the base tile and assembled | Marche angulaire "M" coupée depuis le fond et assemblée | Eckstufe "M", aus dem Boden geschnitten und zusammengesetzt

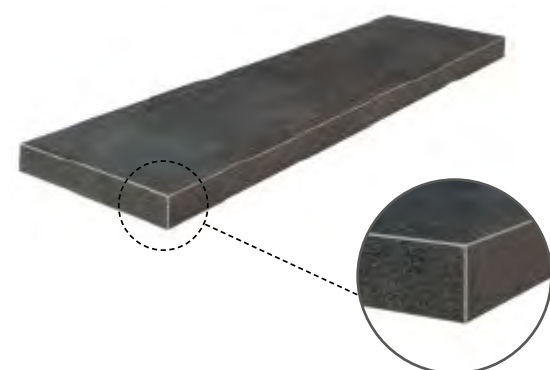

## thickness



La gamma dei pezzi speciali sviluppati per il progetto 2.OUT fornisce un ulteriore ventaglio di possibilità per il mondo del gardening e dell'outdoor: scale, gradoni e angoli, tutti disponibili anche con soluzione antigocciolo "no drip".

The range of trims developed for the 2.OUT project provides an additional array of possibilities for gardens and outdoor locations: stairs, steps and corners, all also available in "no drip" version.

La gamme des pièces spéciales faites pour le projet 2.OUT amplifie encore plus les possibilités pour l'univers du jardinage et de l'extérieur : escaliers, marches et angles, tous les éléments aussi avec solution anti-goutte « no drip ».

Das Sortiment der für 2.OUT entwickelten Formteile eröffnet weitere Möglichkeiten für Garten und Outdoor-Projekte: Treppen, Stufenplatten und Ecken, die alle auch mit „No Drip“-Lösung erhältlich sind.

Grazie alla grafica presente su tutta la superficie, le soluzioni COVER, ingegnerizzate direttamente da Fondovalle, uniscono alla completezza dei pezzi speciali un effetto estetico senza compromessi.

With patterning across the whole surface, COVER solutions, engineered inhouse by Fondovalle, provide a complete range of trims with impeccable look.

Avec leur texture graphique sur toute la surface, les solutions COVER, mises au point directement par Fondovalle, perfectionnent l'exhaustivité des pièces spéciales avec un effet esthétique sans compromis.

Durch ihre Oberflächenstruktur vereinendie direkt von Fondovalle entwickelten COVERLösungen ein umfassendes Sortiment an Formteilen mit einer kompromisslosen Optik.

## gradone toro

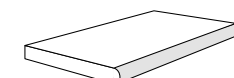

**gradone toro lineare**  
40x80x2 . 15,75"x31,50"x0,78"  
40x100x2 . 15,75"x39,37"x0,78"  
40x120x2 . 15,75"x47,24"x0,78"

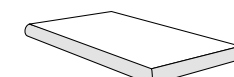

**gradone toro angolare DX**  
40x80x2 . 15,75"x31,50"x0,78"  
40x100x2 . 15,75"x39,37"x0,78"  
40x120x2 . 15,75"x47,24"x0,78"

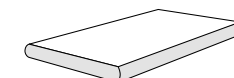

**gradone toro angolare SX**  
40x80x2 . 15,75"x31,50"x0,78"  
40x100x2 . 15,75"x39,37"x0,78"  
40x120x2 . 15,75"x47,24"x0,78"

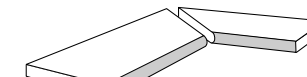

**gradone toro angolare INT SX-DX**  
40x80x2 . 15,75"x31,50"x0,78"  
40x100x2 . 15,75"x39,37"x0,78"  
40x120x2 . 15,75"x47,24"x0,78"



No drip

## elemento L

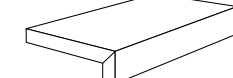

**elemento L lineare**  
40x80x2 . 15,75"x31,50"x0,78"  
40x100x2 . 15,75"x39,37"x0,78"  
40x120x2 . 15,75"x47,24"x0,78"

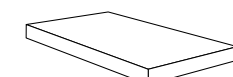

**elemento L angolare DX**  
40x80x2 . 15,75"x31,50"x0,78"  
40x100x2 . 15,75"x39,37"x0,78"  
40x120x2 . 15,75"x47,24"x0,78"



**elemento L angolare SX**  
40x80x2 . 15,75"x31,50"x0,78"  
40x100x2 . 15,75"x39,37"x0,78"  
40x120x2 . 15,75"x47,24"x0,78"

## gradone cover

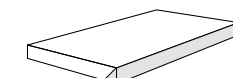

**gradone cover lineare**  
40x80x2 . 15,75"x31,50"x0,78"

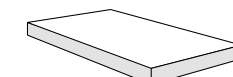

**gradone cover angolare DX**  
40x80x2 . 15,75"x31,50"x0,78"

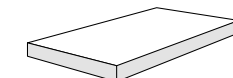

**gradone cover angolare SX**  
40x80x2 . 15,75"x31,50"x0,78"

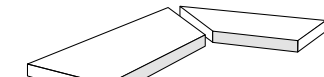

**gradone cover angolare INT SX-DX**  
40x80x2 . 15,75"x31,50"x0,78"



No drip



# stucchi consigliati



Suggested grouts | Mortiers à joint conseillés | Empfohlene Fugenmörtel

Per la posa dei prodotti Fondovalle suggeriamo l'utilizzo della linea di stucchi Ultracolor Plus di Mapei. La nostra selezione segue il principio di un abbinamento tono su tono dello stucco con il colore della piastrella, che andrà sempre verificato per accettazione presso lo show room di vostra fiducia, utilizzando il campionario colore stucchi di Mapei da confrontare con il prodotto selezionato. Le informazioni riportate, pur corrispondendo alla nostra migliore esperienza, sono da ritenersi, in ogni caso, puramente indicative e dovranno essere confermate da esaurienti applicazioni pratiche; **pertanto, prima di adoperare il prodotto, chi intenda farne uso è tenuto a stabilire se esso sia o meno adatto all'impiego previsto e, comunque, si assume ogni responsabilità che possa derivare dal suo uso.**

Ultracolor Plus è una malta cementizia ad alte prestazioni di classe CG2WA (EN 13888), per la stuccatura di fughe da 2 a 20 mm, non irritante e modificata con polimero, a presa ed asciugamento rapido, idrorepellente e antimuffa, esente da ritiri, da crepe e fessurazioni. La superficie finale risulterà essere resistente all'abrasione, liscia e compatta, a basso assorbimento d'acqua, facilmente pulibile e impedirà la formazione di muffe e alghe. I colori saranno uniformi ed esenti da macchiature in quanto il prodotto non produrrà efflorescenze. La pedonabilità sarà garantita dopo circa 3 ore e la messa in esercizio dopo 24 ore (48 ore per vasche e piscine).

Ultracolor Plus è una malta costituita da una miscela di speciali leganti idraulici, inerti di granulometria calibrata, speciali polimeri, additivi idrofobizzanti, molecole organiche e pigmenti. In Ultracolor Plus la tecnologia di Ultracolor è basata su uno speciale legante idraulico autoidratante che garantisce la perfetta uniformità dei colori, attraverso due innovative tecnologie, frutto della ricerca MAPEI: BioBlock® e DropEffect®.

La tecnologia BioBlock® consiste di speciali molecole di natura organica che, distribuendosi omogeneamente nella microstruttura della fuga, impediscono alla radice la formazione dei microrganismi responsabili delle alterazioni dovute alle muffe. La tecnologia DropEffect® (EffettoGoccia), con un effetto sinergico, riduce l'assorbimento di acqua superficiale.

Ultracolor Plus si può utilizzare per stuccature all'interno e all'esterno di pavimenti e rivestimenti in ceramica di ogni tipo con applicazioni in ambito residenziale e commerciale.

Per tutte le informazioni, le avvertenze e le modalità di applicazione, fare sempre riferimento all'ultima versione aggiornata della scheda tecnica Ultracolor Plus, disponibile sul sito [www.mapei.com](http://www.mapei.com)

For the installation of Fondovalle products, we recommend you use the Mapei Ultracolor Plus grout line. This advice is based on the principle of matching the grout and tile colours using a tone-on-tone effect. Always remember to check the shades with your showroom, using the Mapei grout colour samples for comparison with the chosen product. While this advice is based on our experience so far, bear in mind that these recommendations must still be confirmed by further practical applications; therefore, anyone intending to use the product, is required to establish beforehand whether or not it is suitable for the use in question. In any case, the user is entirely responsible for any issues which may arise from its use.

Ultracolor Plus is a high-performance CG2WA class (EN 13888) cement mortar for grouting joints measuring from 2 to 20 mm; it is non-irritating, polymer-modified, quick-setting and drying, water-repellent and mouldproof, non-shrinking, not prone to cracks or fissures. The tiled surface will be abrasion-resistant, smooth and compact, with low water absorption, easy to clean and will prevent the formation of mould and algae. The colours will be even and stain-free as the product is not prone to blooming. Walkability will be guaranteed after about 3 hours and the area can be used after 24 hours (48 hours for swimming pools).

Ultracolor Plus mortar is a mixture of special hydraulic binders, aggregates with a calibrated grain size, special polymers, hydrophobic additives, organic molecules and pigments. In Ultracolor Plus, the Ultracolor technology is based on a special self-hydrating hydraulic binder that guarantees a perfectly even colour through the application of two innovative technologies, originating from MAPEI research, namely BioBlock® and DropEffect®.

BioBlock® technology consists of special organic molecules which, distributed evenly through the microstructure of the joint, prevent the formation of the micro-organisms responsible for changes caused by mould or mildew. DropEffect® technology creates a synergistic effect to reduce absorption of surface water.

Ultracolor Plus can be used for grouting indoors and out, with all kinds of ceramic floor and wall tiles in residential and business settings.

For further information, warnings, and application methods, always refer to the latest updated version of the Ultracolor Plus technical data sheet, which is available on the website ([www.mapei.com](http://www.mapei.com)).

Pour la pose des produits Fondovalle, nous recommandons d'utiliser la ligne de mortiers à joint Ultracolor Plus de Mapei. Notre sélection suit le principe d'un assortiment ton sur ton du mortier avec la couleur du carreau, qui doit toujours être vérifiée pour acceptation dans votre salle d'exposition de confiance, en utilisant la collection d'échantillons de couleur de mortiers Mapei pour comparer avec le produit sélectionné. Dès qu'elles correspondent à notre meilleure expérience, les informations fournies sont dans tous les cas purement indicatives et doivent être confirmées par des applications pratiques exhaustives; par conséquent, avant d'utiliser le produit, quiconque a l'intention de l'utiliser doit établir s'il convient ou non à l'usage prévu et, dans tous les cas, assumer toute responsabilité pouvant découler de son utilisation.

Ultracolor Plus est un mortier de ciment hautement performant de classe CG2WA (EN 13888), pour le jointoiment de joints de 2 à 20 mm, non irritant et modifié avec du polymère, à prise et séchage rapides, hydrofuge et anti-moisissure, sans retraits, fissures ni fentes. La surface finale sera résistante à l'abrasion, lisse et compacte, avec une faible absorption d'eau, facile à nettoyer et empêchera la formation de moisissures et d'algues. Les couleurs seront uniformes et exemptes de taches, car le produit ne produira pas d'efflorescence. La praticabilité sera garantie après environ 3 heures et la mise en service après 24 heures (48 heures pour les bassins et les piscines).

Ultracolor Plus est un mortier constitué d'un mélange de liants hydrauliques spéciaux, d'agrégats de granulométrie calibrée, de polymères spéciaux, d'additifs hydrophobes, de molécules organiques et de pigments. Dans Ultracolor Plus, la technologie d'Ultracolor est basée sur un liant hydraulique spécial auto-hydratant qui garantit une parfaite uniformité des couleurs, grâce à deux technologies innovantes qui sont le résultat de la recherche MAPEI: BioBlock® et DropEffect®.

La technologie BioBlock® consiste en des molécules organiques spéciales qui, en se répartissant de manière homogène dans la microstructure du joint, empêchent la formation de micro-organismes responsables des altérations causées par les moisissures à la racine. La technologie DropEffect® (Effet Goutte), avec un effet synergique, réduit l'absorption des eaux de surface.

Ultracolor Plus peut être utilisé pour le jointoiment intérieur et extérieur des sols et des murs en céramique de tous types pour des applications résidentielles et commerciales.

Pour toutes les informations, les avertissements et les méthodes d'application, veuillez toujours vous référer à la dernière version de la fiche technique d'Ultracolor Plus, disponible sur [www.mapei.com](http://www.mapei.com)

Zur Verlegung der Produkte von Fondovalle empfehlen wir die Verwendung der Linie von Fugenmörtel Ultracolor Plus von Mapei. Unsere Wahl folgt dem Prinzip einer Kombination Ton-in-Ton zwischen dem Fugenmörtel und der Farbe der Fliese, die beim Ausstellungsraum Ihres Vertrauens immer auf Akzeptanz geprüft werden muss. Verwenden Sie dazu das Farbmuster der Fugenmörtel von Mapei, um es mit dem ausgewählten Produkt zu vergleichen. Die gemeldeten Informationen entsprechen zwar unseren besten Erfahrungen, sind jedoch in jedem Fall als reine Richtwerte zu betrachten und müssen durch umfassende praktische Anwendungen bestätigt werden. Daher muss jeder, der das Produkt verwenden möchte, vor der Verwendung feststellen, ob es für den beabsichtigten Gebrauch geeignet ist oder nicht, und übernimmt in jedem Fall die Verantwortung, die sich aus seiner Verwendung ergeben kann.

Ultracolor Plus ist ein Zementmörtel mit hohen Leistungen der Klasse CG2WA (EN 13888) zum Verschließen von Fugen von 2 bis 20 mm, der nicht reizt und mit Polymer modifiziert wurde, schnell abbindet und trocknet, wasserabweisend, schimmelhemmend, nicht schrumpft sowie keine Sprünge und Risse bildet. Die fertige Oberfläche ist abriebfest, glatt und kompakt, hat eine geringe Wasseraufnahme, ist leicht zu reinigen und verhindert die Bildung von Schimmel und Algen. Die Farben sind gleichmäßig und frei von Flecken, da das Produkt keine Ausblühungen hervorruft. Die Begehrbarkeit wird nach ca. 3 Stunden und die Inbetriebnahme nach 24 Stunden garantiert (48 Stunden bei Wannen und Schwimmbädern).

Ultracolor Plus ist ein Mörtel, der aus einer Mischung spezieller hydraulischer Bindemittel, Aggregaten mit kalibrierter Korngröße, speziellen Polymeren, hydrophoben Zusatzstoffen, organischen Molekülen und Pigmenten besteht. Bei Ultracolor Plus basiert die Ultracolor-Technologie auf einem speziellen selbsthydratisierenden hydraulischen Bindemittel, das durch zwei innovative Technologien, die das Ergebnis der Forschung von MAPEI sind, eine vollkommene Gleichmäßigkeit der Farben garantiert: BioBlock® und DropEffect®.

Die Technologie BioBlock® besteht aus speziellen organischen Molekülen, die durch ihre gleichmäßige Verteilung in der Mikrostruktur der Fuge von Anfang an die Bildung von Mikroorganismen verhindern, die für die Veränderungen aufgrund von Schimmel verantwortlich sind. Die Technologie DropEffect® (Tropfen-Effekt) mit synergistischem Effekt reduziert die Aufnahme von Oberflächenwasser.

Ultracolor Plus kann zum Verschließen von Fugen von Keramikböden und -wänden jeglicher Art im Innen- und Außenbereich mit Anwendungen in Wohn- und Geschäftsbereich verwendet werden.

Alle Informationen, Hinweise und Anwendungsmethoden finden Sie immer in der neuesten überarbeiteten Version des technischen Datenblattes von Ultracolor Plus, das auf der Website [www.mapei.com](http://www.mapei.com) verfügbar ist.

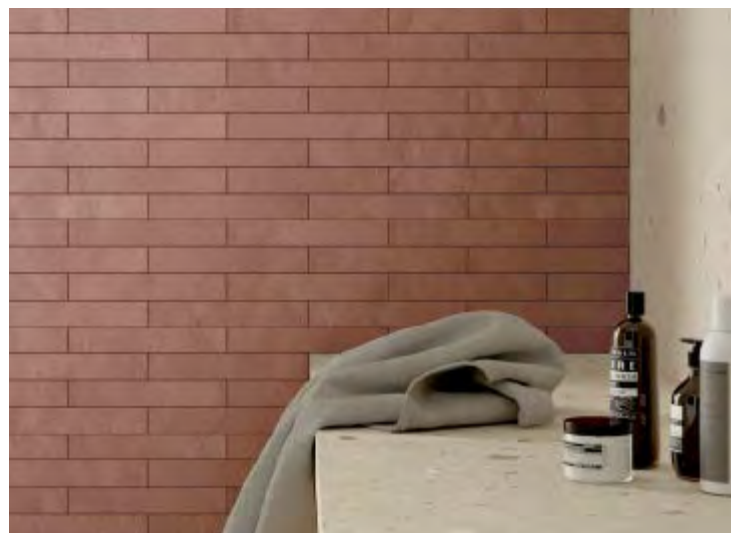

## Ultracolor Plus

100 . White	114 . Anthracite	125 . Castle Grey	135 . Golden Dust	152 . Liquorice	188 . Biscuit
103 . Moon White	115 . River Grey	127 . Arctic Grey	136 . Mud	169 . Steel Blue	
110 . Manhattan 2000	116 . Musk Grey	130 . Jasmine	137 . Caribbean	170 . Crocus Blue	
111 . Silver Grey	119 . London Grey	132 . Beige 2000	138 . Almond	172 . Space Blue	
112 . Medium Grey	120 . Black	133 . Sand	142 . Brown	174 . Tornado	
113 . Cement Grey	123 . Ancient White	134 . Silk	149 . Volcano Sand	187 . Linen	



# caratteristiche tecniche



Technical characteristics | Caracteristiques technique | Technische eigenschaften

Lastre / piastrelle di ceramica in gres porcellanato - Gruppo Bla UGL (UNI EN 14411_G)   Porcelain stoneware slabs / tiles - Gruppe Bla UGL (UNI EN 14411_G)   Dalles / carreaux en céramique en grès céram - Group Bla UGL (UNI EN 14411_G)   Keramikplatten / keramikfliesen aus Feinsteinzeug - Groupe Bla UGL (UNI EN 14411_G)		Metodo di prova Test method Méthode d'essai Prüfmethode	Requisiti prescritti Required value Valeur requise Vorgeschriebener Wert	Risultato Results Résultat Ergebnis	Valutazione Valutation Évaluation Bewertung	
				L < 120 cm	L ≥ 120 cm	
	Lunghezza e larghezza   Length and width   Longueur et largeur   Länge und Breite		± 0,6% ± 2 mm	± 0,6% ± 0,5 mm	± 0,6% ± 0,9 mm	Conforme   Compliant   Conforme   Konform
	Spessore   Thickness   Epaisseur   Stärke		± 5% ± 0,5 mm	± 5% ± 0,5 mm	± 3% ± 0,5 mm	Conforme   Compliant   Conforme   Konform
	Rettilinearità degli spigoli   Edge straightness   Rectitude des arêtes   Rechtlinigkeit der Kanten		± 0,5% ± 1,5 mm	± 0,5% ± 1,5 mm	± 0,5% ± 1,5 mm	Conforme   Compliant   Conforme   Konform
	Ortogonalità   Rectangularity   Orthogonalité   Rechtwinkligkeit	UNI EN ISO 10545-2	± 0,5% ± 2 mm	± 0,5 % ± 1 mm	± 0,5 % ± 2 mm	Conforme   Compliant   Conforme   Konform
	Planarità   Planarity   Planéité   Rechtwinkligkeit		± 0,5% ± 2 mm	± 0,5 % ± 2 mm	± 0,5 % ± 2 mm	Conforme   Compliant   Conforme   Konform
Qualità della superficie   Surface quality   Qualité de la surface   Oberflächenqualität		≥ 95%	Conforme Compliant Conforme Konform	Conforme Compliant Conforme Konform	Conforme   Compliant   Conforme   Konform	
	Assorbimento d'acqua   Water Absorption   Absorption d'eau   Wasseraufnahme	UNI EN ISO 10545-3	≤ 0,5%	≤ 0,1%		Conforme   Compliant   Conforme   Konform
	Resistenza alla flessione   Bending strength   Resistance a la flexion   Biegezugfestigkeit	UNI EN ISO 10545-4	Modulo di rottura Modulus of rupture Module de rupture Bruchlast	h = 6,5 mm; R ≥ 50 N/mm <sup>2</sup> h = 8,5 mm; R ≥ 45 N/mm <sup>2</sup> h = 10 mm; R ≥ 45 N/mm <sup>2</sup>		Conforme   Compliant   Conforme   Konform
			R average ≥ 35 N/mm <sup>2</sup> R min ≥ 32 N/mm <sup>2</sup>	h = 2 cm; R ≥ 40 N/mm <sup>2</sup>		
			Sforzo di rottura Breaking strength Effort de rupture Bruchkraft	h = 6,5 mm; S > 700 N h = 8,5 mm; S > 1300 N h = 10 mm; S ≥ 1300 N	h = 2 cm; S ≥ 9000 N	Conforme   Compliant   Conforme   Konform
	Resistenza all'abrasione profonda   Deep abrasion resistance   Résistance à l'abrasion profonde   Tiefenverschleißbeständigkeit	UNI EN ISO 10545-6	V ≤ 175 mm <sup>3</sup>	h = 6,5 mm; V ≤ 130 mm <sup>3</sup> h = 8,5 mm; V ≤ 145 mm <sup>3</sup> h = 10 mm; V ≤ 145 mm <sup>3</sup> h = 2 cm; V ≤ 145 mm <sup>3</sup>		Conforme   Compliant   Conforme   Konform
	Resistenza agli sbalzi termici   Resistance to thermal shock   Résistance aux écarts de température   Temperaturwechselbeständigkeit	UNI EN ISO 10545-9	Resistente   Resistant   Résistant   Widerstandsfähig	Resistente   Resistant   Résistant   Widerstandsfähig		Conforme   Compliant   Conforme   Konform
	Resistenza al gelo   Frost resistance   Résistance au gel   Frostbeständigkeit	UNI EN ISO 10545-12	Resistente   Resistant   Résistant   Widerstandsfähig	Ingelivo   Frost proof   Ingelif   Frostsicher		Conforme   Compliant   Conforme   Konform
	Resistenza all'attacco chimico   Chemical resistance   Resistance a l'attaque chimique   Beständigkeit gegen chemikalien	UNI EN ISO 10545-13	Valori dichiarati   Declared values   Valeurs déclarées   Erklärte Werte	<b>A; LA; HA</b> <b>A; LB; HB</b> Honed, Glossy		Conforme   Compliant   Conforme   Konform
	Resistenza alle macchie   Stain resistance   Resistance aux taches   Fleckenbeständigkeit	UNI EN ISO 10545-14	Minimo Classe 3   Minimum Class 3   Classe 3 minimale   Mindestklasse 3	Valori dichiarati   Declared values   Valeurs déclarées   Erklärte Werte		Conforme   Compliant   Conforme   Konform
	Resistenza dei colori alla luce   Colour resistance to light exposure   Résistance des couleurs à la lumière   Farbechtheit unter Lichteinfluss	DIN 51094	Resistente   Resistant   Résistant   Widerstandsfähig	Resistente   Resistant   Résistant   Widerstandsfähig		Conforme   Compliant   Conforme   Konform

\* Con trattamento su richiesta. Valore da verificare su ogni singolo lotto produttivo | With treatment available on request. Check rating for each production batch | Avec traitement sur demande. Valeur à vérifier sur chaque lot de production | Auf Anfrage mit Behandlung. Wert bei jeder einzelnen Charge des Produktes zu prüfen

\*\* Valori dichiarati ottenuti da test di laboratorio. Possono subire variazioni in base al lotto produttivo | Stated values are obtained from laboratory tests. They may vary depending on the production batch | Valeurs déclarées basées sur des essais en laboratoire. Peutvent subir des variations en fonction du lot de production | Die angegebenen Werte basieren auf Labortests. Es kann von Charge zu Charge zu Abweichungen kommen

Lastre / piastrelle di ceramica in gres porcellanato - Gruppo Bla UGL (UNI EN 14411_G)   Porcelain stoneware slabs / tiles - Gruppe Bla UGL (UNI EN 14411_G)   Dalles / carreaux en céramique en grès céram - Group Bla UGL (UNI EN 14411_G)   Keramikplatten / keramikfliesen aus Feinsteinzeug - Groupe Bla UGL (UNI EN 14411_G)		Metodo di prova Test method Méthode d'essai Prüfmethode	Requisiti prescritti Required value Valeur requise Vorgeschriebener Wert	Risultato Results Résultat Ergebnis	Valutazione Valutation Évaluation Bewertung		
				L < 120 cm	L ≥ 120 cm		
	Resistenza allo scivolamento a piedi nudi   Slip resistance with bare feet   Résistance au glissement pieds nus   Rutschfestigkeit bei nackten Füßen	DIN EN 16165_A	Da A a C From A to C De A à C Von A bis C	<b>A</b> Infinito 2.0 nat., Monochrome nat., Res Art <b>A+B</b> Acidic, Action, Background, Homescape, Keynote, Pigmento, Planeto, Portland, Reframe, Royal Travertino, Shards nat., Urban Craft, Upper, Woodblock <b>A+B+C*</b> Komi 2.OUT, Pigmento 2.OUT, Planeto 2.OUT, Portland 2.OUT, Stone Lab 2.OUT, Upper 2.OUT, Urban Craft 2.OUT	Conforme   Compliant   Conforme   Konform		
				Resistenza allo scivolamento a piedi calzati   Slip resistance with shod feet   Résistance au glissement des chaussures   Rutschfestigkeit bei beschuhten Füßen	Da R9 a R13 From R9 to R13 De R9 à R13 Von R9 bis R13	<b>R 9</b> Infinito 2.0 nat., Monochrome nat., Res Art <b>R 10**</b> Acidic, Action, Background, Homescape, Keynote, Pigmento, Planeto, Portland, Reframe, Royal Travertino, Shards nat., Urban Craft, Upper, Woodblock <b>R 11**</b> Komi 2.OUT, Pigmento 2.OUT, Planeto 2.OUT, Portland 2.OUT, Stone Lab 2.OUT, Upper 2.OUT, Urban Craft 2.OUT	Conforme   Compliant   Conforme   Konform
				Resistenza allo scivolamento DCOF   Skid resistance DCOF   Résistance au glissement DCOF   Rutschhemmung DCOF	ANSI A 137.1:2012	> 0,42 wet	> 0,42 wet
		BCRA	> 0,40 dry leather > 0,40 wet rubber	> 0,40 dry > 0,40 wet	Conforme   Compliant   Conforme   Konform		
	Resistenza allo scivolamento PENDULUM   Skid resistance PENDULUM   Résistance au glissement PENDULUM   Rutschhemmung PENDULUM	BS EN 16165_C	on request ≥ 36	<b>dry rubber 4S: ≥ 36**</b> <b>wet rubber 4S: ≥ 36**</b> Action, Background, Homescape, Keynote, Pigmento, Planeto 2.OUT, Portland, Reframe, Royal Travertino, Shards nat., Urban Craft, Upper, Woodblock <b>dry rubber 4S: ≥ 36*</b> <b>wet rubber 4S: on request ≥ 36*</b> Acidic, Infinito 2.0 nat., Monochrome nat., Planeto, Res Art	Conforme   Compliant   Conforme   Konform		
			AS 4586	on request P3	<b>P3**</b> Action, Background, Homescape, Keynote, Pigmento, Planeto 2.OUT, Portland, Reframe, Royal Travertino, Shards nat., Urban Craft, Upper, Woodblock <b>P3: on request**</b> Acidic, Infinito 2.0 nat., Monochrome nat., Planeto, Res Art	Conforme   Compliant   Conforme   Konform	
			UNE-ENV 12633	on request Class 2	<b>Class 2**</b> Action, Background, Homescape, Keynote, Pigmento, Planeto 2.OUT, Portland, Reframe, Royal Travertino, Shards nat., Urban Craft, Upper, Woodblock <b>Class 2 on request**</b> Acidic, Infinito 2.0 nat., Monochrome nat., Planeto, Res Art	Conforme   Compliant   Conforme   Konform	
	Reazione al fuoco   Fire reaction   Résistance au feu   Feuerfestigkeit	UNI EN 13501-1	Resistente   Resistant   Résistant   Widerstandsfähig	Resistente A1 FL Resistant A1 FL Résistant A1 FL Widerstandsfähig A1 FL	Conforme   Compliant   Conforme   Konform		









# caratteristiche tecniche









Technical characteristics | Caracteristiques technique | Technische eigenschaften

Lastre di ceramica in gres porcellanato - Gruppo Bla GL (UNI EN 14411\_G) | Porcelain stoneware slabs - Gruppe Bla GL (UNI EN 14411\_G) | Dalles en céramique en grès céram - Group Bla GL (UNI EN 14411\_G) | Keramikplatten aus Feinsteinzeug - Groupe Bla GL (UNI EN 14411\_G)

	Metodo di prova Test method Méthode d'essai Prüfmethode	Requisiti prescritti Required value Valeur requise Vorgeschriebener Wert	Risultato Results Résultat Ergebnis		Valutazione Valutation Évaluation Bewertung
			L < 120 cm	L ≥ 120 cm	
 Lunghezza e larghezza   Length and width   Longueur et largeur   Länge und Breite		± 0,6% ± 2 mm	± 0,6% ± 0,5 mm ± 0,75 mm (Brit)	± 0,6% ± 0,9 mm	Conforme   Compliant   Conforme   Konform
Spessore   Thickness   Epaisseur   Stärke		± 5% ± 0,5 mm	± 5% ± 0,5 mm	± 3% ± 0,5 mm	Conforme   Compliant   Conforme   Konform
Rettilinearità degli spigoli   Edge straightness   Rectitude des arêtes   Rechtlinigkeit der Kanten		± 0,5% ± 2 mm	± 0,5% ± 2 mm	± 0,5% ± 2 mm	Conforme   Compliant   Conforme   Konform
Ortogonalità   Rectangularity   Orthogonalité   Rechtwinkligkeit	UNI EN ISO 10545-2	± 0,5% ± 2 mm	± 0,5% ± 1 mm ± 0,75 mm (Brit)	± 0,5% ± 2 mm	Conforme   Compliant   Conforme   Konform
Planarità   Planarity   Planéité   Rechtwinkligkeit		± 0,5% ± 2 mm	± 0,5% ± 2 mm ± 0,75 mm (Brit)	± 0,5% ± 2 mm	Conforme   Compliant   Conforme   Konform
Qualità della superficie   Surface quality   Qualité de la surface   Oberflächenqualität		≥ 95%	Conforme   Compliant   Conforme   Konform	Conforme   Compliant   Conforme   Konform	Conforme   Compliant   Conforme   Konform
 Assorbimento d'acqua   Water Absorption   Absorption d'eau   Wasseraufnahme	UNI EN ISO 10545-3	≤ 0,5%	≤ 0,1%		Conforme   Compliant   Conforme   Konform
 Resistenza alla flessione   Bending strength   Resistance a la flexion   Biegezugfestigkeit	UNI EN ISO 10545-4	Modulo di rottura Modulus of rupture Module de rupture Bruchlast R average ≥ 35 N/mm <sup>2</sup> R min ≥ 32 N/mm <sup>2</sup> Sforzo di rottura Breaking strength Effort de rupture Bruchkraft h ≥ 7,5 mm; S > 1300 N h < 7,5 mm; S > 700 N	h = 6,5 mm; R ≥ 50 N/mm <sup>2</sup> h = 9 mm; R ≥ 35 N/mm <sup>2</sup> (Brit)		Conforme   Compliant   Conforme   Konform
 Resistenza all'abrasione superficiale   Resistance to surface abrasion   Resistance a l'abrasion superficielle   Beständigkeit gegen oberflächenverschleiss	UNI EN ISO 10545-6	1 - 5	Conforme   Compliant   Conforme   Konform	Conforme   Compliant   Conforme   Konform	Conforme   Compliant   Conforme   Konform
 Resistenza agli sbalzi termici   Resistance to thermal shock   Résistance aux écarts de température   Temperaturwechselbeständigkeit	UNI EN ISO 10545-9	Resistente   Resistant   Résistant   Widerstandsfähig	Resistente   Resistant   Résistant   Widerstandsfähig		Conforme   Compliant   Conforme   Konform
 Resistenza al gelo   Frost resistance   Résistance au gel   Frostbeständigkeit	UNI EN ISO 10545-12	Resistente   Resistant   Résistant   Widerstandsfähig	Ingelivo   Frost proof   Ingelif   Frostsicher		Conforme   Compliant   Conforme   Konform

586 TECH INFO

Lastre di ceramica in gres porcellanato - Gruppo Bla GL (UNI EN 14411\_G) | Porcelain stoneware slabs - Gruppe Bla GL (UNI EN 14411\_G) | Dalles en céramique en grès céram - Group Bla GL (UNI EN 14411\_G) | Keramikplatten aus Feinsteinzeug - Groupe Bla GL (UNI EN 14411\_G)

	Metodo di prova Test method Méthode d'essai Prüfmethode	Requisiti prescritti Required value Valeur requise Vorgeschriebener Wert	Risultato Results Résultat Ergebnis		Valutazione Valutation Évaluation Bewertung
			L < 120 cm	L ≥ 120 cm	
 Resistenza all'attacco chimico   Chemical resistance   Resistance a l'attaque chimique   Beständigkeit gegen chemikalien Acidi e basi ad alta e bassa concentrazione   High- and low-concentration acids and bases   Acides et bases à haute et basse concentration   Säuren und Basen mit hoher und niedriger Konzentration	UNI EN ISO 10545-13	Valori dichiarati   Declared values   Valeurs déclarées   Erklärte Werte B minimo   B minimum   B minimum   Mind. B	A; LA; HA		Conforme   Compliant   Conforme   Konform
 Resistenza alle macchie   Stain resistance   Resistance aux taches   Fleckenbeständigkeit	UNI EN ISO 10545-14	Minimo Classe 3   Minimum Class 3   Classe 3 minimale   Mindestklasse 3	Valori dichiarati   Declared values   Valeurs déclarées   Erklärte Werte		Conforme   Compliant   Conforme   Konform
 Resistenza dei colori alla luce   Colour resistance to light exposure   Résistance des couleurs à la lumière   Farbchtheit unter Lichteinfluss	DIN 51094	Resistente   Resistant   Résistant   Widerstandsfähig	Resistente   Resistant   Résistant   Widerstandsfähig		Conforme   Compliant   Conforme   Konform
 Resistenza allo scivolamento a piedi nudi   Slip resistance with bare feet   Résistance au glissement pieds nus   Rutschfestigkeit bei nackten Füßen	DIN EN 16165_A	Da A a C From A to C De A à C Von A bis C	A+B Dream, Komi		Conforme   Compliant   Conforme   Konform
 Resistenza allo scivolamento a piedi calzati   Slip resistance with shod feet   Résistance au glissement des chaussures   Rutschfestigkeit bei beschuhten Füßen	DIN EN 16165_B	Da R9 a R13 From R9 to R13 De R9 à R13 Von R9 bis R13	R 10 Dream, Komi		Conforme   Compliant   Conforme   Konform
Resistenza allo scivolamento DCOF   Skid resistance DCOF   Résistance au glissement DCOF   Rutschhemmung DCOF	ANSI A 137.1:2012	> 0,42 wet	> 0,42 wet		Conforme   Compliant   Conforme   Konform
	BCRA	> 0,40 dry leather > 0,40 wet rubber	> 0,40 dry > 0,40 wet		Conforme   Compliant   Conforme   Konform
 Resistenza allo scivolamento PENDULUM   Skid resistance PENDULUM   Résistance au glissement PENDULUM   Rutschhemmung PENDULUM	BS EN 16165_C	on request ≥ 36	dry rubber 4S: ≥ 36* wet rubber 4S: ≥ 36* Dream, Komi		Conforme   Compliant   Conforme   Konform
	AS 4586	on request P3	P3* Dream, Komi		Conforme   Compliant   Conforme   Konform
	UNE-ENV 12633	on request Class 2	Class 2* Dream, Komi		Conforme   Compliant   Conforme   Konform
 Reazione al fuoco   Fire reaction   Résistance au feu   Feuerfestigkeit	UNI EN 13501-1	Resistente   Resistant   Résistant   Widerstandsfähig	Resistente A1 FL Resistant A1 FL Résistant A1 FL Widerstandsfähig A1 FL		Conforme   Compliant   Conforme   Konform

\* Valori dichiarati ottenuti da test di laboratorio. Possono subire variazioni in base al lotto produttivo | Stated values are obtained from laboratory tests. They may vary depending on the production batch | Valeurs déclarées basées sur des essais en laboratoire. Peuvent subir des variations en fonction du lot de production | Die angegebenen Werte basieren auf Labortests. Es kann von Charge zu Charge zu Abweichungen kommen

587 TECH INFO



# caratteristiche tecniche lastre

Slab specifications | Caractéristiques techniques des dalles | Technische Daten der Platten

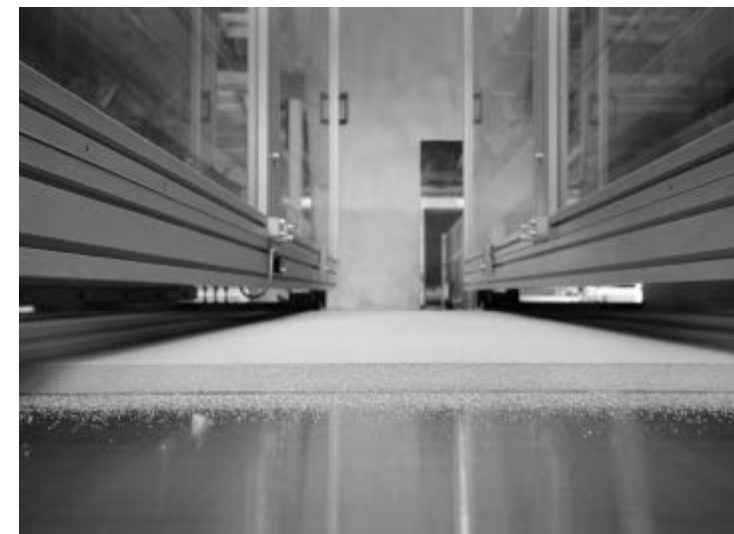
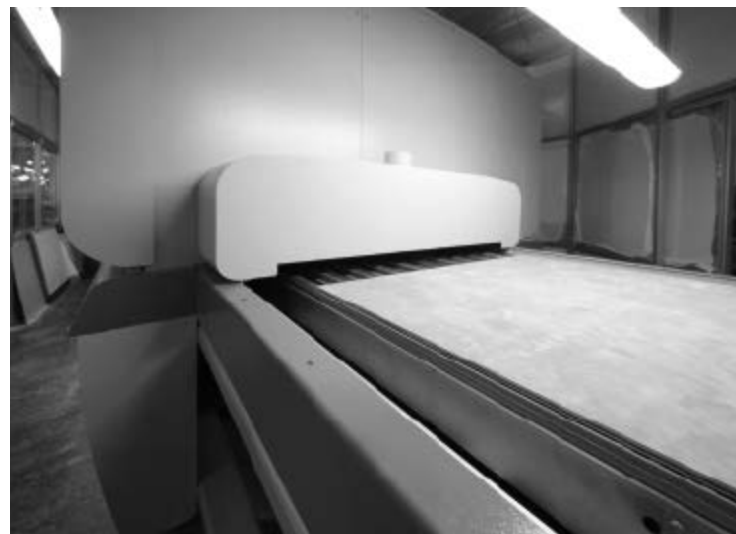

Nascono da un processo produttivo avanzato e unico messo a punto da Ceramica Fondovalle nel suo stabilimento di Casona di Marano, immerso nel magnifico parco naturale dei Sassi di Rocca Malatina, con la collaborazione di uno dei più importanti leader dell'automazione per ceramica. I materiali possiedono elevate caratteristiche tecniche, la loro produzione avviene nel rispetto dei migliori standard tecnico-qualitativi propri di Fondovalle e nel rispetto dell'ambiente naturale circostante. La nuova tecnologia offre la possibilità di utilizzare e miscelare materie prime tradizionali o di nuova generazione, valorizzando la creatività e la ricerca dei nostri tecnici. Le lastre sono prodotte in spessore 6,5 mm.

## self leveling

In uno spessore di soli 6,5 mm sono racchiuse caratteristiche tecniche di grande forza, elasticità e flessibilità. Queste elevate caratteristiche tecniche, garantite da una tecnologia all'avanguardia e da impasti pregiati, accompagnate dagli attuali sistemi di posa, consentono di realizzare pavimentazioni perfettamente planari, impensabili con altri materiali ceramici.

## formati

Il nuovo impianto permette di realizzare differenti tagli direttamente sul prodotto a crudo, cioè appena compattato. I formati disponibili sono: 160x320, 120x278, 120x120, 60x120, 40x240, 24x240, 24x120.

## destinazioni d'uso

Le caratteristiche tecniche delle lastre le rendono idonee a molteplici applicazioni in ambienti domestici, pubblici e ad alto traffico pedonale (negozi, hall, aeroporti,...), con pose a pavimento e a rivestimento, e grazie allo spessore sottile, anche in sovrapposizione a pavimentazioni esistenti senza interventi di demolizione.

Per i consigli di posa, consultare il sito [www.fondovalle.it](http://www.fondovalle.it)

These products are the result of a unique cutting- edge manufacturing process developed by Ceramica Fondovalle at its plant in Casona di Marano, in the magnificent Sassi di Rocca Malatina natural park, working in partnership with one of the major leaders in automated systems for the ceramic tile industry. These materials offer advanced technical features and are manufactured in compliance with Fondovalle's highest technical and quality standards, respecting the natural environment of the surrounding area. The new technology offers the possibility to use and mix traditional or new-generation materials, enhancing and stimulating the creativity and research of our technical staff. The slabs are available in thickness 6,5 mm.

## self leveling

The thickness of only 6.5 mm encloses technical characteristics of great strength, elasticity and flexibility. These advanced technical features, guaranteed by cutting edge technology and high quality mixtures, combined with the current laying systems, ensure perfectly flat floor installations, otherwise impossible to achieve with other ceramic materials.

## sizes

The new system produces different sizes by cutting the unfired, just pressed products. The material is available in the following sizes: 160x320, 120x278, 120x120, 60x120, 40x240, 24x240, 24x120.

## fields of application

The technical features of the slabs make them suitable for use in homes and public environments and in areas with high footfall (shops, halls, airports.); they can be used for floor and wall coverings and, thanks to their slim design, they can be laid over existing floors without any demolition work.

For more details, please visit our site at [www.fondovalle.it](http://www.fondovalle.it)

Elles naissent d'un processus de production avancé et unique mis au point par Ceramica Fondovalle en son usine de Casona di Marano, immergée dans le parc naturel magnifique des Sassi de Rocca Malatina, avec la collaboration d'un des principaux leaders de l'automatisation du secteur de la céramique. Le matériel possède d'importantes caractéristiques techniques et il est produit dans le respect des meilleurs standards techniques et qualitatifs propres à Fondovalle ainsi que dans le respect de la nature environnante. La nouvelle technologie permet d'utiliser et de mélanger des matières premières traditionnelles ou de nouvelle génération, en valorisant la créativité et la recherche de la part de nos techniciens. Les dalles sont fabriquées dans l'épaisseur 6,5 mm.

## self leveling

L'épaisseur de 6,5 mm seulement contient des caractéristiques techniques comme la grande force, l'élasticité et la flexibilité. Ces caractéristiques techniques importantes, garanties par une technologie d'avant-garde et par des pâtes précieuses associées aux systèmes de pose actuels, permettent de réaliser des carrelages parfaitement plats, impensables avec d'autres matériaux en céramique.

## formats

La nouvelle installation permet de réaliser différentes coupes directement sur le produit à cru, c'est-à-dire qui vient tout juste d'être compacté. Les formats disponibles sont : 160x320, 120x278, 120x120, 60x120, 40x240, 24x240, 24x120.

## usage prévu

Grâce à leurs caractéristiques techniques, les dalles sont indiqués pour de nombreuses applications en milieu domestique, dans les lieux publics et à haute fréquentation piétonne (magasins, halls, aéroports, etc.), au sol et sur les murs, et grâce à l'épaisseur réduite, également en superposition sur des carrelages existants sans intervention de démolition.

Pour les conseils de pose, consulter le site [www.fondovalle.it](http://www.fondovalle.it)

Sie entstehen aus einem fortschrittlichen und einzigartigen Produktionsprozess, der von der Firma Ceramica Fondovalle in ihrem Werk in Casona di Marano, das vom herrlichen Naturpark Sassi di Rocca Malatina umgeben ist, in Zusammenarbeit mit einem der wichtigsten der führenden Unternehmen der Automatisierung für die Keramik geschaffen wurde. Die Materialien verfügen über hohe technische Eigenschaften und ihre Herstellung erfolgt unter Einhaltung der besten technisch-qualitativen Firmenstandards von Fondovalle und unter dem Schutz der umliegenden Natur. Die neue Technologie bietet die Möglichkeit, herkömmliche Rohstoffe oder Rohstoffe der neusten Generation einzusetzen und sie miteinander zu mischen, so dass die Kreativität und die Forschung unserer Techniker zur Geltung kommen. Die Platten werden in der Stärke 6,5 mm.

## self leveling

In einer Stärke von nur 6,5 mm sind technische Eigenschaften von großer Kraft, Elastizität und Flexibilität eingeschlossen. Diese hohen technischen Merkmale, die durch eine wegweisende Technologie und wertvolle Gemische, zusammen mit den heutigen Verlegesystemen, garantiert werden, ermöglichen die Schaffung von hundertprozentig ebenen Böden, die mit anderen Keramikmaterialien undenkbar sind.

## formate

Mit der neuen Anlage können unterschiedliche Zuschnitte direkt am Rohprodukt vorgenommen werden, d.h. am soeben verdichteten Produkt. Folgende Formate sind erhältlich: 160x320, 120x278, 120x120, 60x120, 40x240, 24x240, 24x120.

## verwendungszwecke

Aufgrund ihrer technischen Merkmale eignen sich die Platten für vielfältige Anwendungen in Wohnräumen, öffentlichen Bereichen und Bereichen mit starkem Fußgängerverkehr (Geschäfte, Hotelhallen, Flughäfen, ...) bei Verlegung auf dem Boden und an den Wänden sowie, dank der geringen Stärke, auch zum Abdecken von vorhandenen Bodenbelägen ohne vorherige Demolierung des Altbodens.

Für Verlegeempfehlungen siehe auf der Internetseite [www.fondovalle.it](http://www.fondovalle.it)









# codici prezzo e imballi

Price and packaging codes | Codes prix et emballages | Codes für Preis und Verpackungen

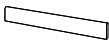

## acidic

formato size	spessore thickness	superfici surfaces	colori colors		
			CORTEN	IRON	SILVER
 <b>120x278</b> Rettificato 47,24"x109,45"	6,5 mm	Natural	ACD099	ACD101	ACD100
 <b>120x120</b> Rettificato 47,24"x47,24"	6,5 mm	Natural	ACD020	ACD004	ACD024
 <b>8x120 battiscopa</b> 3,15"x47,24"	6,5 mm	Natural	ACD021	ACD018	ACD027

## action

formato size	spessore thickness	superfici surfaces	colori colors	
			LIGHT	DARK
 <b>120x278</b> Rettificato 47,24"x109,45"	6,5 mm	Natural	ACT066	ACT067
 <b>120x120</b> Rettificato 47,24"x47,24"	6,5 mm	Natural	ACT014	ACT004
 <b>60x120</b> Rettificato 23,62"x47,24"	6,5 mm	Natural	ACT063	ACT062
 <b>120x120 decoro Paint</b> 47,24"x47,24"	6,5 mm	Natural	ACT018	ACT008
 <b>8x120 battiscopa</b> 3,15"x47,24"	6,5 mm	Natural	ACT009	ACT019
 <b>33x120x5 gradino lineare LL</b> 12,99"x47,24"x1,97"	6,5 mm	Natural	ACT010	ACT020
 <b>33x120x5 gradino angolare LL</b> 12,99"x47,24"x1,97"	6,5 mm	Natural	ACT016	ACT006

## background

formato size	spessore thickness	superfici surfaces	colori colors			
			SNOWY	CREAM	CLOUD	CAVIAR
 <b>120x278</b> Rettificato 47,24"x109,45"	6,5 mm	Real Matt	BAG005	BAG006	BAG007	BAG008
 <b>120x120</b> Rettificato 47,24"x47,24"	6,5 mm	Real Matt	BAG013	BAG014	BAG015	BAG016
 <b>60x120</b> Rettificato 23,62"x47,24"	8,5 mm	Real Matt	BAG025	BAG026	BAG027	BAG028

pz / box	m² / box	kg / box	box / pallet	m² / pallet	kg / pallet	m² x pcs.	kg / m²	kg / crate	total kg	dimensione esterna cassa crate overall dimensions	codice prezzo price code
1	3,33	51,61	18	59,94	929,00	3,33	15,50	101	1030,00	291x134x31,5 cm	MF017
2	2,88	44,64	20	57,60	892,80	1,44	15,50	54	946,80	130,2x130,2x40 cm	MF012
7	-	10,50	solo scatole complete   complete boxes only   à la boîte complète   nur kartonsweise								PF004

pz / box	m² / box	kg / box	box / pallet	m² / pallet	kg / pallet	m² x pcs.	kg / m²	kg / crate	total kg	dimensione esterna cassa crate overall dimensions	codice prezzo price code
1	3,33	51,61	18	59,94	929,00	3,33	15,50	101	1030,00	291x134x31,5 cm	MF017
2	2,88	44,64	20	57,60	892,80	1,44	15,50	54	946,80	130,2x130,2x40 cm	MF012
2	1,44	22,32	40	57,60	892,80	-	-	-	-	-	MF011
2	2,88	44,64	20	57,60	892,80	1,44	15,50	54	946,80	130,2x130,2x40 cm	MF014
7	-	10,50	solo scatole complete   complete boxes only   à la boîte complète   nur kartonsweise								PF004
2	-	15,00	solo scatole complete   complete boxes only   à la boîte complète   nur kartonsweise								PF030
1	-	7,50	solo scatole complete   complete boxes only   à la boîte complète   nur kartonsweise								PF032









pz / box	m² / box	kg / box	box / pallet	m² / pallet	kg / pallet	m² x pcs.	kg / m²	kg / crate	total kg	dimensione esterna cassa crate overall dimensions	codice prezzo price code
1	3,33	51,61	18	59,94	929,00	3,33	15,50	101	1030,00	291x134x31,5 cm	MF017
2	2,88	44,64	20	57,60	892,80	1,44	15,50	54	946,80	130,2x130,2x40 cm	MF012
2	1,44	28,00	32	46,08	911,00	-	-	-	-	-	MF004

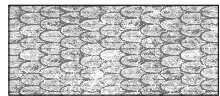

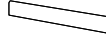
# codici prezzo e imballi

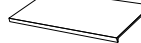
Price and packaging codes | Codes prix et emballages | Codes für Preis und Verpackungen

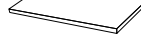
## background

formato size	spessore thickness	superfici surfaces	colori colors			
			SNOWY	CREAM	CLOUD	CAVIAR
 80x80 Rettificato 31,50"x31,50"	8,5 mm	Real Matt	BAG033	BAG034	BAG035	BAG036
 120x278 decoro Empaire 47,24"x109,45"	6,5 mm	Real Matt 3D Texture	BAG095	BAG096	BAG097	BAG098
 60x120 decoro Line 23,62"x47,24"	8,5 mm	Real Matt	BAG029	BAG030	BAG031	BAG032
 8x120 battiscopa 3,15"x47,24"	6,5 mm	Real Matt	BAG037	BAG038	BAG039	BAG040
 8x80 battiscopa 3,15"x31,50"	8,5 mm	Real Matt	BAG049	BAG050	BAG051	BAG052
 33x120x5 gradino lineare LL 12,99"x47,24"x1,97"	6,5 mm	Real Matt	BAG041	BAG042	BAG043	BAG044
 40x80x5 gradino lineare M 15,75"x31,50"x1,97"	8,5 mm	Real Matt	BAG053	BAG054	BAG055	BAG056
 33x120x5 gradino angolare LL 12,99"x47,24"x1,97"	6,5 mm	Real Matt	BAG045	BAG046	BAG047	BAG048
 40x80x5 gradino angolare M 15,75"x31,50"x1,97"	8,5 mm	Real Matt	BAG057	BAG058	BAG059	BAG060

## brit

formato size	spessore thickness	superfici surfaces	colori colors					
			WHITE	PEARL GREY	ALMOND	TOBACCO	MINT	OCEAN
 6x24,6 2,36"x9,68"	9 mm	Shiny	BRI001	BRI003	BRI002	BRI006	BRI004	BRI005

## dream

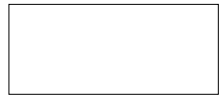
formato size	spessore thickness	superfici surfaces	colori colors													
			COTTON	SNOW	GROUND	NAVY BLUE	SAGE	PEACOCK	BLOOM	ROMANTIC	PLUME	GLAM	CAMELLIA	GARDEN	LIGHT SIDE	JUNGLE
 120x278 Rettificato 47,24"x109,45"	6,5 mm	Natural	DRM095	DRM121	DRM123	DRM096	DRM097									
 120x278 decori 47,24"x109,45"	6,5 mm	Natural			DRM179	DRM127	DRM129	DRM125	DRM104	DRM102	DRJ009	DRM099				
			DRM177	DRM117	-	-	-	-	-	-	-	-				

## homescape

formato size	spessore thickness	superfici surfaces	colori colors				
			SUGAR	CLAY	COAL	CARAMEL	MATCHA
 120x278 Rettificato 47,24"x109,45"	6,5 mm	Natural	HOM016	HOM017	HOM018	HOM020	HOM019

pz / box	m² / box	kg / box	box / pallet	m² / pallet	kg / pallet	m² x pcs.	kg / m²	kg / crate	total kg	dimensione esterna cassa crate overall dimensions	codice prezzo price code	
2	1,28	23,30	50	64,00	1165,00	-	-	-	-	-	MF005	
1	3,33	51,61	18	59,94	929,00	3,33	15,50	101	1030,00	291x134x31,5 cm	MF026	
2	1,44	27,99	32	46,08	895,68	-	-	-	-	-	MF009	
7	-	10,50	solo scatole complete   complete boxes only   à la boîte complète   nur kartonsweise									PF005
8	-	9,28	solo scatole complete   complete boxes only   à la boîte complète   nur kartonsweise									PF002
2	-	15,00	solo scatole complete   complete boxes only   à la boîte complète   nur kartonsweise									PF031
2	-	11,64	solo scatole complete   complete boxes only   à la boîte complète   nur kartonsweise									PF023
1	-	7,50	solo scatole complete   complete boxes only   à la boîte complète   nur kartonsweise									PF035
1	-	5,82	solo scatole complete   complete boxes only   à la boîte complète   nur kartonsweise									PF024

pz / box	m² / box	kg / box	box / pallet	m² / pallet	kg / pallet	m² x pcs.	kg / m²	kg / crate	total kg	dimensione esterna cassa crate overall dimensions	codice prezzo price code
34	0,50	10,20	120	60,00	1224,00	0,05	20,40	-	-	-	MF008

pz / box	m² / box	kg / box	box / pallet	m² / pallet	kg / pallet	m² x pcs.	kg / m²	kg / crate	total kg	dimensione esterna cassa crate overall dimensions	codice prezzo price code
1	3,33	51,61	18	59,94	929,00	3,33	15,50	101	1030,00	291x134x31,5 cm	MF017
1	3,33	51,61	18	59,94	929,00	3,33	15,50	101	1030,00	291x134x31,5 cm	MF022 MF026











pz / box	m² / box	kg / box	box / pallet	m² / pallet	kg / pallet	m² x pcs.	kg / m²	kg / crate	total kg	dimensione esterna cassa crate overall dimensions	codice prezzo price code
1	3,33	51,61	18	59,94	929,00	3,33	15,50	101	1030,00	291x134x31,5 cm	MF017









# codici prezzo e imballi

Price and packaging codes | Codes prix et emballages | Codes für Preis und Verpackungen

## homescape

formato size	spessore thickness	superfici surfaces	colori colors				
			SUGAR	CLAY	COAL	CAMEL	MATCHA
 120x120 Rettificato 47,24"x47,24"	6,5 mm	Natural	HOM006	HOM007	HOM008	HOM010	HOM009
 60x120 Rettificato 23,62"x47,24"	8,5 mm	Natural	HOM087	HOM088	HOM089	HOM091	HOM090
 80x80 Rettificato 31,50"x31,50"	8,5 mm	Natural	HOM097	HOM098	HOM099	HOM101	HOM100
 60x120 decoro Tub 23,62"x47,24"	8,5 mm	Natural	HOM092	HOM093	HOM094	HOM096	HOM095
 8x120 battiscopa 3,15"x47,24"	6,5 mm	Natural	HOM036	HOM037	HOM038	HOM040	HOM039
 8x80 battiscopa 3,15"x31,50"	8,5 mm	Natural	HOM051	HOM052	HOM053	HOM055	HOM054
 33x120x5 gradino lineare LL 12,99"x47,24"x1,97"	6,5 mm	Natural	HOM041	HOM042	HOM043	HOM045	HOM044
 40x80x5 gradino lineare M 15,75"x31,50"x1,97"	8,5 mm	Natural	HOM056	HOM057	HOM058	HOM060	HOM059
 33x120x5 gradino angolare LL 12,99"x47,24"x1,97"	6,5 mm	Natural	HOM046	HOM047	HOM048	HOM050	HOM049
 40x80x5 gradino angolare M 15,75"x31,50"x1,97"	8,5 mm	Natural	HOM061	HOM062	HOM063	HOM065	HOM064

## infinito 2.0

formato size	spessore thickness	superfici surfaces	colori colors							
			CARRARA C	STATUARIO EXTRA	STATUARIO	LINCOLN	CALACATTA WHITE	CALACATTA LIGHT	ELEGANT WHITE	CALACATTA GOLD
 160x320 Rettificato • 62,99"x125,98"	6,5 mm	Glossy	INF1096	INF1042	INF749	INF467	INF416	INF1300	-	INF501
		Bookmatch Glossy	-	A_INF1045 B_INF1046	A_INF758 B_INF759	-	A_INF358 B_INF360	A_INF1305 B_INF1306	-	A_INF506 B_INF507
		Honed	INF1095	INF1041	INF748	INF466	INF415	INF1299	-	INF500
		Bookmatch Honed	-	A_INF1043 B_INF1044	A_INF756 B_INF757	-	A_INF421 B_INF422	A_INF1303 B_INF1304	-	A_INF504 B_INF505
		Natural	-	-	-	-	-	-	INF2192	-
 120x278 Rettificato 47,24"x109,45"	6,5 mm	Glossy	INF1138	INF1165	INF1156	INF1153	INF1183	INF1281	-	INF1174
		Honed	INF1137	INF1164	INF1155	INF1152	INF1182	INF1280	-	INF1173
		Natural	-	INF1909	-	-	-	-	-	INF1917
 60x120 Rettificato 23,62"x47,24"	6,5 mm	Glossy	INF1101	INF1058	INF864	INF824	INF818	INF1534	-	INF821
 8x120 battiscopa 3,15"x47,24"	6,5 mm	Glossy	INF1103	INF1060	INF765	INF318	INF698	INF1312	-	INF610
 33x120x5 gradino lineare LL 12,99"x47,24"x1,97"	6,5 mm	Glossy	INF1106	INF1062	INF768	INF596	INF591	INF1315	-	INF613
 33x120x5 gradino angolare LL 12,99"x47,24"x1,97"	6,5 mm	Glossy	INF1107	INF1064	INF771	INF598	INF593	INF1318	-	INF616

• Disponibile su richiesta | Available on request | Disponible sur demande | Auf Anfrage erhältlich

pz / box	m² / box	kg / box	box / pallet	m² / pallet	kg / pallet	m² x pcs.	kg / m²	kg / crate	total kg	dimensione esterna cassa crate overall dimensions	codice prezzo price code
2	2,88	44,64	20	57,60	892,80	1,44	15,50	54	946,80	130,2x130,2x40 cm	MF012
2	1,44	27,99	32	46,08	895,68	-	-	-	-	-	MF004
2	1,28	23,29	50	64,00	1165,00	-	-	-	-	-	MF005
2	1,44	27,99	32	46,08	895,68	-	-	-	-	-	MF009
7	-	10,50	solo scatole complete   complete boxes only   à la boîte complète   nur kartonsweise								PF005
8	-	9,28	solo scatole complete   complete boxes only   à la boîte complète   nur kartonsweise								PF002
2	-	15,00	solo scatole complete   complete boxes only   à la boîte complète   nur kartonsweise								PF031
2	-	11,64	solo scatole complete   complete boxes only   à la boîte complète   nur kartonsweise								PF023
1	-	7,50	solo scatole complete   complete boxes only   à la boîte complète   nur kartonsweise								PF035
1	-	5,82	solo scatole complete   complete boxes only   à la boîte complète   nur kartonsweise								PF024

pz / box	m² / box	kg / box	box / pallet	m² / pallet	kg / pallet	m² x pcs.	kg / m²	kg / crate	total kg	dimensione esterna cassa crate overall dimensions	codice prezzo price code
1	5,12	79,36	14	71,68	1111,00	5,12	15,50	153	1264,00	343,2x172,6x36,2 cm	MF028
											MF025
1	3,33	51,61	18	59,94	929,00	3,33	15,50	101	1030,00	291x134x31,5 cm	MF027
											MF020
2	1,44	22,32	40	57,60	893,00	-	-	-	-	-	MF022
7	-	10,50	solo scatole complete   complete boxes only   à la boîte complète   nur kartonsweise								PF007
2	-	15,00	solo scatole complete   complete boxes only   à la boîte complète   nur kartonsweise								PF038
1	-	7,50	solo scatole complete   complete boxes only   à la boîte complète   nur kartonsweise								PF040



# codici prezzo e imballi

Price and packaging codes | Codes prix et emballages | Codes für Preis und Verpackungen

## infinito 2.0

formato size	spessore thickness	superfici surfaces	colori colors							
			CAPRAIA	ONICE WHITE	CALACATTA MACCHIA VECCHIA	FIOR DI BOSCO	SAHARA NOIR	OMBRA DI CARAVAGGIO	SUPER WHITE	PORT LAURENT
	6,5 mm	Glossy	INF1246	INF1082	-	INF552	INF345	INF872	-	-
		<i>Bookmatch</i> Glossy	A_INF1251 B_INF1252	-	-	-	-	A_INF876 B_INF878	-	-
		Honed	INF1245	-	-	INF551	INF478	INF871	-	-
		<i>Bookmatch</i> Honed	A_INF1249 B_INF1250	-	-	-	-	A_INF875 B_INF877	-	-
	6,5 mm	Glossy	INF1351	INF1135	INF1878	INF1150	INF1133	INF1141	INF1747	INF1731
		Honed	INF1484	-	-	INF1149	INF1132	INF1140	-	-
		Natural	INF1913	-	-	INF1921	-	-	INF1905	-
	6,5 mm	Glossy	INF1615	INF1087	-	INF827	INF830	INF868	INF1752	INF1736
	6,5 mm	Glossy	INF1616	INF1088	-	INF601	INF314	INF915	INF1753	INF1737
	6,5 mm	Glossy	INF1617	INF1089	-	INF604	INF586	INF921	INF1754	INF1738
	6,5 mm	Glossy	INF1618	INF1090	-	INF607	INF588	INF924	INF1755	INF1739
	6,5 mm	Glossy	INF1629	INF1888	INF2161	INF1882	INF2276	-	INF1655	INF1757
		Honed	-	-	-	-	-	-	-	-
		Natural	-	-	-	-	-	INF1874	-	-
	6,5 mm	Glossy	-	-	-	-	-	-	INF1952	-
	6,5 mm	Glossy	INF1886	INF1642	INF2270	INF1633	-	-	-	-
		Honed	-	-	-	-	-	-	-	-
		Natural	-	-	-	-	-	INF1925	-	-
	6,5 mm	Glossy	-	-	-	-	-	-	-	-

pz / box	m² / box	kg / box	box / pallet	m² / pallet	kg / pallet	m² x pcs.	kg / m²	kg / crate	total kg	dimensione esterna cassa crate overall dimensions	codice prezzo price code
1	5,12	79,36	14	71,68	1111,00	5,12	15,50	153	1264,00	343,2x172,6x36,2 cm	MF028
											MF025
1	3,33	51,61	18	59,94	929,00	3,33	15,50	101	1030,00	291x134x31,5 cm	MF027
											MF020
2	1,44	22,32	40	57,60	893,00	-	-	-	-	-	MF022
7	-	10,50	solo scatole complete   complete boxes only   à la boîte complète   nur kartonsweise								PF007
2	-	15,00	solo scatole complete   complete boxes only   à la boîte complète   nur kartonsweise								PF038
1	-	7,50	solo scatole complete   complete boxes only   à la boîte complète   nur kartonsweise								PF040
1	3,33	51,61	18	59,94	929,00	3,33	15,50	101	1030,00	291x134x31,5 cm	MF027
											MF020
2	1,44	22,32	40	57,60	893,00	-	-	-	-	-	MF022
1	3,33	51,61	18	59,94	929,00	3,33	15,50	101	1030,00	291x134x31,5 cm	MF027
											MF020
2	1,44	22,32	40	57,60	893,00	-	-	-	-	-	MF022

596 TECH INFO











597 TECH INFO





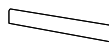

# codici prezzo e imballi

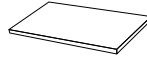
Price and packaging codes | Codes prix et emballages | Codes für Preis und Verpackungen

## keynote

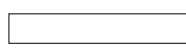
formato size	spessore thickness	superfici surfaces	colori colors			
			PEARL	AMBER	ARCTIC	COOL GREY
 120x278 Rettificato 47,24"x109,45"	6,5 mm	Natural	KEY019	KEY020	KEY022	KEY023
 120x120 Rettificato 47,24"x47,24"	6,5 mm	Natural	KEY007	KEY008	KEY010	KEY011
 60x120 Rettificato 23,62"x47,24"	8,5 mm	Natural	KEY153	KEY154	KEY156	KEY157
	10 mm •	Natural	KEY025	KEY026	KEY028	KEY029
 80x80 Rettificato 31,50"x31,50"	8,5 mm	Natural	KEY165	KEY166	KEY168	KEY169
	10 mm •	Natural	KEY037	KEY038	KEY040	KEY041
 40x80 Rettificato 15,75"x31,50"	8,5 mm	Natural	KEY177	KEY178	KEY180	KEY181
	10 mm •	Natural	KEY049	KEY050	KEY052	KEY053
 5x30 Listello 1,97"x11,81"	6,5 mm	Natural	KEY097	KEY098	KEY100	KEY101
 8x120 battiscopa 3,15"x47,24"	6,5 mm	Natural	KEY055	KEY056	KEY058	KEY059
	8,5 mm	Natural	KEY073A	KEY074A	KEY076A	KEY077A
 8x80 battiscopa 3,15"x31,50"	10 mm •	Natural	KEY073	KEY074	KEY076	KEY077
	6,5 mm	Natural	KEY061	KEY062	KEY064	KEY065
 33x120x5 gradino lineare LL 12,99"x47,24"x1,97"	8,5 mm	Natural	KEY079A	KEY080A	KEY082A	KEY083A
	10 mm •	Natural	KEY079	KEY080	KEY082	KEY083
 40x80x5 gradino lineare M 15,75"x31,50"x1,97"	6,5 mm	Natural	KEY067	KEY068	KEY070	KEY071
	8,5 mm	Natural	KEY085A	KEY086A	KEY088A	KEY089A
 33x120x5 gradino angolare LL 12,99"x47,24"x1,97"	10 mm •	Natural	KEY085	KEY086	KEY088	KEY089
	8,5 mm	Natural	KEY085A	KEY086A	KEY088A	KEY089A

## komi

formato size	spessore thickness	superfici surfaces	colori colors				
			ORIGINAL	NATURAL	TRADITIONAL	ELEGANT	CLASSIC
 40x240 Rettificato 15,75"x94,49"	6,5 mm	Natural	KOM018	KOM002	KOM026	KOM106	KOM107
 24x240 Rettificato 9,45"x94,49"	6,5 mm	Natural	KOM019	KOM003	KOM027	KOM108	KOM109
 24x120 Rettificato 9,45"x47,24"	6,5 mm	Natural	KOM096	KOM095	KOM097	KOM104	KOM105
 40x120 Rettificato 15,75"x47,24"	2 cm 2.OUT	Grip	KOM136	KOM135	KOM134	-	-
 120x278 decoro Elegant Lodge 47,24"x109,45"	6,5 mm	Natural	-	-	-	KOM124	-

pz / box	m² / box	kg / box	box / pallet	m² / pallet	kg / pallet	m² x pcs.	kg / m²	kg / crate	total kg	dimensione esterna cassa crate overall dimensions	codice prezzo price code
1	3,33	51,61	18	59,94	929,00	3,33	15,50	101	1030,00	291x134x31,5 cm	■ MF017
2	2,88	44,64	20	57,60	892,80	1,44	15,50	54	946,80	130,2x130,2x40 cm	■ MF012
2	1,44	27,99	32	46,08	895,68	-	-	-	-	-	■ MF004
2	1,44	31,10	32	46,08	995,00	-	-	-	-	-	■ MF004
2	1,28	23,30	50	64,00	1165,00	-	-	-	-	-	■ MF005
2	1,28	28,50	50	64,00	1425,00	-	-	-	-	-	■ MF005
3	0,96	18,20	36	34,56	655,00	-	-	-	-	-	■ MF003
4	1,28	27,64	48	61,44	1327,00	-	-	-	-	-	■ MF003
33	0,495	7,67	-	-	-	-	-	-	-	-	■ MD021
7	-	10,50	solo scatole complete   complete boxes only   la boîte complète   nur kartonsweise								● PF004
8	-	9,28	solo scatole complete   complete boxes only   la boîte complète   nur kartonsweise								● PF002
6	-	9,60	solo scatole complete   complete boxes only   la boîte complète   nur kartonsweise								● PF002
2	-	15,00	solo scatole complete   complete boxes only   la boîte complète   nur kartonsweise								● PF030
2	-	11,64	solo scatole complete   complete boxes only   la boîte complète   nur kartonsweise								● PF023
2	-	13,80	solo scatole complete   complete boxes only   la boîte complète   nur kartonsweise								● PF023
1	-	7,50	solo scatole complete   complete boxes only   la boîte complète   nur kartonsweise								● PF032
1	-	5,82	solo scatole complete   complete boxes only   la boîte complète   nur kartonsweise								● PF024
1	-	6,90	solo scatole complete   complete boxes only   la boîte complète   nur kartonsweise								● PF024









pz / box	m² / box	kg / box	box / pallet	m² / pallet	kg / pallet	m² x pcs.	kg / m²	kg / crate	total kg	dimensione esterna cassa crate overall dimensions	codice prezzo price code
1	0,96	14,88	36	34,56	535,68	0,960	15,50	56	591,68	252x94x30,4 cm	■ MF015
1	0,58	8,99	54	31,10	485,00	0,576	15,50	56	541,00	252x94x30,4 cm	■ MF015
5	1,44	22,32	40	57,60	893,00	0,290	15,50	20	913,00	80x122x74 cm with lateral side	■ MF011
2	0,96	42,62	24	23,08	1022,88	-	-	-	-	-	■ MF016
1	3,33	51,61	18	59,94	929,00	3,33	15,50	101	1030,00	291x134x31,5 cm	■ MF022

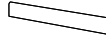

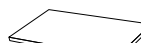
# codici prezzo e imballi

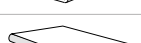
Price and packaging codes | Codes prix et emballages | Codes für Preis und Verpackungen

## komi

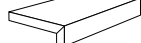
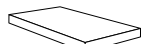
formato size	spessore thickness	superfici surfaces	colori colors				
			ORIGINAL	NATURAL	TRADITIONAL	ELEGANT	CLASSIC
 5x120 battiscopa 1,97"x47,24"	6,5 mm	Natural	KOM043	KOM041	KOM044	KOM110	KOM111
 33x120x5 gradino lineare LL 12,99"x47,24"x1,97"	6,5 mm	Natural	KOM049	KOM045	KOM051	KOM112	KOM113
 33x120x5 gradino angolare LL 12,99"x47,24"x1,97"	6,5 mm	Natural	KOM050	KOM046	KOM052	KOM114	KOM115
 40x120x2 gradone toro lineare 15,75"x47,24"x0,78"	2 cm 2.OUT	Grip	KOM151	KOM144	KOM137	-	-
 40x120x2 gradone toro angolare dx 15,75"x47,24"x0,78"	2 cm 2.OUT	Grip	KOM152	KOM145	KOM138	-	-
 40x120x2 gradone toro angolare sx 15,75"x47,24"x0,78"	2 cm 2.OUT	Grip	KOM153	KOM146	KOM139	-	-
 40x120x2 comp. gradone toro angolare interno 15,75"x47,24"x0,78"	2 cm 2.OUT	Grip	KOM154	KOM147	KOM140	-	-
 40x120x5 elemento L lineare 15,75"x47,24"x1,97"	2 cm 2.OUT	Grip	KOM155	KOM148	KOM141	-	-
 40x100x5 elemento L angolare dx 15,75"x39,37"x1,97"	2 cm 2.OUT	Grip	KOM156	KOM149	KOM142	-	-
 40x100x5 elemento L angolare sx 15,75"x39,37"x1,97"	2 cm 2.OUT	Grip	KOM157	KOM150	KOM143	-	-

## monochrome

formato size	spessore thickness	superfici surfaces	colori colors	
			WHITE	BLACK
 160x320 Rettificato • 62,99"x125,98"	6,5 mm	Glossy	MNC004	-
Natural		MNC005	MNC006	

## pigmento

formato size	spessore thickness	superfici surfaces	colori colors						
			GESSO	FANGO	POLVERE	CARBONE	ORO	MATTONE	OSSIDO
 120x278 Rettificato 47,24"x109,45"	6,5 mm	Natural	PGM029	PGM030	PGM031	PGM032	PGM035	PGM034	PGM033
 120x120 Rettificato 47,24"x47,24"	6,5 mm	Natural	PGM008	PGM009	PGM010	PGM011	PGM014	PGM013	PGM012
 60x120 Rettificato 23,62"x47,24"	6,5 mm	Natural	PGM015	PGM016	PGM017	PGM018	PGM021	PGM020	PGM019

• Disponibile su richiesta | Available on request | Disponible sur demande | Auf Anfrage erhältlich

pz / box	m² / box	kg / box	box / pallet	m² / pallet	kg / pallet	m² x pcs.	kg / m²	kg / crate	total kg	dimensione esterna cassa crate overall dimensions	codice prezzo price code
7	-	6,30								solo scatole complete   complete boxes only   à la boîte complète   nur kartonsweise	● PF004
2	-	15,00								solo scatole complete   complete boxes only   à la boîte complète   nur kartonsweise	● PF030
1	-	7,50								solo scatole complete   complete boxes only   à la boîte complète   nur kartonsweise	● PF032
1	-	21,30								solo scatole complete   complete boxes only   à la boîte complète   nur kartonsweise	● PF015
1	-	21,30								solo scatole complete   complete boxes only   à la boîte complète   nur kartonsweise	● PF026
1	-	21,30								solo scatole complete   complete boxes only   à la boîte complète   nur kartonsweise	● PF026
2	-	42,60								solo scatole complete   complete boxes only   à la boîte complète   nur kartonsweise	● PF039
1	-	23,90								solo scatole complete   complete boxes only   à la boîte complète   nur kartonsweise	● PF021
1	-	23,90								solo scatole complete   complete boxes only   à la boîte complète   nur kartonsweise	● PF028
1	-	23,90								solo scatole complete   complete boxes only   à la boîte complète   nur kartonsweise	● PF028

pz / box	m² / box	kg / box	box / pallet	m² / pallet	kg / pallet	m² x pcs.	kg / m²	kg / crate	total kg	dimensione esterna cassa crate overall dimensions	codice prezzo price code
1	5,12	79,36	14	71,68	1111,00	5,12	15,50	153	1264,00	343,2x172,6x36,2 cm	■ MF028 ■ MF025













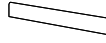

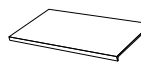

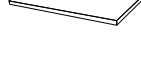
pz / box	m² / box	kg / box	box / pallet	m² / pallet	kg / pallet	m² x pcs.	kg / m²	kg / crate	total kg	dimensione esterna cassa crate overall dimensions	codice prezzo price code
1	3,33	51,61	18	59,94	929,00	3,33	15,50	101	1030,00	291x134x31,5 cm	■ MF017
2	2,88	44,64	20	57,60	892,80	1,44	15,50	54	946,80	130,2x130,2x40 cm	■ MF012
2	1,44	22,32	40	57,60	892,80	0,72	15,50	20	912,80	80x122x74 cm with lateral side	■ MF011

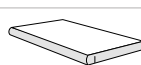
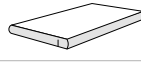
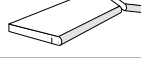

# codici prezzo e imballi

Price and packaging codes | Codes prix et emballages | Codes für Preis und Verpackungen

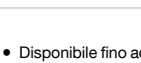
## pigmento

formato size	spessore thickness	superfici surfaces	colori colors						
			GESSO	FANGO	POLVERE	CARBONE	ORO	MATTONE	OSSIDO
	8,5 mm	Natural	PGM202	PGM204	PGM203	PGM205	-	-	-
	10 mm •	Natural	PGM036	PGM037	PGM038	PGM039	-	-	-
	2 cm 2.OUT	Grip	PGM132	PGM131	PGM133	-	-	-	-
	8,5 mm	Natural	PGM210	PGM212	PGM211	PGM213	-	-	-
	10 mm •	Natural	PGM044	PGM045	PGM046	PGM047	-	-	-
	6,5 mm	Natural	PGM048	PGM049	PGM050	PGM051	PGM054	PGM053	PGM052
	8,5 mm	Natural	PGM069A	PGM070A	PGM071A	PGM072A	-	-	-
	10 mm •	Natural	PGM069	PGM070	PGM071	PGM072	-	-	-
	6,5 mm	Natural	PGM055	PGM056	PGM057	PGM058	PGM061	PGM060	PGM059
	8,5 mm	Natural	PGM073A	PGM074A	PGM075A	PGM076A	-	-	-
	10 mm •	Natural	PGM073	PGM074	PGM075	PGM076	-	-	-
	6,5 mm	Natural	PGM062	PGM063	PGM064	PGM065	PGM068	PGM067	PGM066
	8,5 mm	Natural	PGM077A	PGM078A	PGM079A	PGM080A	-	-	-
	10 mm •	Natural	PGM077	PGM078	PGM079	PGM080	-	-	-
	2 cm 2.OUT	Grip	PGM153	PGM134	PGM173	-	-	-	-
	2 cm 2.OUT	Grip	PGM154	PGM135	PGM174	-	-	-	-
	2 cm 2.OUT	Grip	PGM155	PGM136	PGM175	-	-	-	-
	2 cm 2.OUT	Grip	PGM156	PGM137	PGM176	-	-	-	-
	2 cm 2.OUT	Grip	PGM157	PGM138	PGM177	-	-	-	-
	2 cm 2.OUT	Grip	PGM158	PGM139	PGM178	-	-	-	-
	2 cm 2.OUT	Grip	PGM159	PGM140	PGM179	-	-	-	-
	2 cm 2.OUT	Grip	PGM160	PGM141	PGM180	-	-	-	-
	2 cm 2.OUT	Grip	PGM164	PGM145	PGM184	-	-	-	-
	2 cm 2.OUT	Grip	PGM166	PGM146	PGM185	-	-	-	-
	2 cm 2.OUT	Grip	PGM167	PGM147	PGM186	-	-	-	-
	2 cm 2.OUT	Grip	PGM168	PGM148	PGM187	-	-	-	-
	2 cm 2.OUT	Grip							

pz / box	m² / box	kg / box	box / pallet	m² / pallet	kg / pallet	m² x pcs.	kg / m²	kg / crate	total kg	dimensione esterna cassa crate overall dimensions	codice prezzo price code
2	1,28	23,30	50	64,00	1165,00	-	-	-	-	-	MF005
2	1,28	28,50	50	64,00	1425,00	-	-	-	-	-	MF015
1	0,64	30,53	40	26,50	1221,00	-	-	-	-	-	MF003
3	0,96	18,20	36	34,56	655,00	-	-	-	-	-	
4	1,28	27,64	48	61,44	1327,00	-	-	-	-	-	
7	-	10,50	solo scatole complete   complete boxes only   à la boîte complète   nur kartonsweise								PF004
8	-	9,28	solo scatole complete   complete boxes only   à la boîte complète   nur kartonsweise								PF002
6	-	9,60	solo scatole complete   complete boxes only   à la boîte complète   nur kartonsweise								PF030
2	-	15,00	solo scatole complete   complete boxes only   à la boîte complète   nur kartonsweise								PF023
2	-	15,00	solo scatole complete   complete boxes only   à la boîte complète   nur kartonsweise								PF032
1	-	7,50	solo scatole complete   complete boxes only   à la boîte complète   nur kartonsweise								PF024
1	-	7,50	solo scatole complete   complete boxes only   à la boîte complète   nur kartonsweise								PF009
1	-	15,30	solo scatole complete   complete boxes only   à la boîte complète   nur kartonsweise								PF014
1	-	15,30	solo scatole complete   complete boxes only   à la boîte complète   nur kartonsweise								PF014
2	-	30,50	solo scatole complete   complete boxes only   à la boîte complète   nur kartonsweise								PF037
1	-	15,30	solo scatole complete   complete boxes only   à la boîte complète   nur kartonsweise								PF011
1	-	15,30	solo scatole complete   complete boxes only   à la boîte complète   nur kartonsweise								PF016
1	-	15,30	solo scatole complete   complete boxes only   à la boîte complète   nur kartonsweise								PF016
2	-	30,50	solo scatole complete   complete boxes only   à la boîte complète   nur kartonsweise								PF029
1	-	15,30	solo scatole complete   complete boxes only   à la boîte complète   nur kartonsweise								PF012
1	-	15,30	solo scatole complete   complete boxes only   à la boîte complète   nur kartonsweise								PF019
1	-	15,30	solo scatole complete   complete boxes only   à la boîte complète   nur kartonsweise								PF019
2	-	30,50	solo scatole complete   complete boxes only   à la boîte complète   nur kartonsweise								PF033

602 THE BRAND

603 THE BRAND











# codici prezzo e imballi

Price and packaging codes | Codes prix et emballages | Codes für Preis und Verpackungen

## pigmento

formato size	spessore thickness	superfici surfaces	colori colors							
			GESSO	FANGO	POLVERE	CARBONE	ORO	MATTONE	OSSIDO	
 <b>40x80x2 gradone cover lineare nodrip</b> 15,75"x31,50"x0,78"	2 cm 2.OUT	Grip	PGM169	PGM149	PGM188	-	-	-	-	
 <b>40x80x2 gradone cover angolare dx nodrip</b> 15,75"x31,50"x0,78"	2 cm 2.OUT	Grip	PGM170	PGM150	PGM189	-	-	-	-	
 <b>40x80x2 gradone cover angolare sx nodrip</b> 15,75"x31,50"x0,78"	2 cm 2.OUT	Grip	PGM171	PGM151	PGM190	-	-	-	-	
 <b>40x80x2 comp. gradone cover angolare interno nodrip</b> 15,75"x31,50"x0,78"	2 cm 2.OUT	Grip	PGM172	PGM152	PGM191	-	-	-	-	
 <b>40x80x5 elemento L lineare</b> 15,75"x31,50"x1,97"	2 cm 2.OUT	Grip	PGM161	PGM142	PGM181	-	-	-	-	
 <b>40x80x5 elemento L angolare dx</b> 15,75"x31,50"x1,97"	2 cm 2.OUT	Grip	PGM162	PGM143	PGM182	-	-	-	-	
 <b>40x80x5 elemento L angolare sx</b> 15,75"x31,50"x1,97"	2 cm 2.OUT	Grip	PGM163	PGM144	PGM183	-	-	-	-	

## planeto

formato size	spessore thickness	superfici surfaces	colori colors				
			VENUS	MOON	MARS	JUPITER	PLUTO
 <b>120x278 Rettificato</b> 47,24"x109,45"	6,5 mm	Natural	PNT111	PNT110	PNT109	PNT108	PNT107
 <b>120x120 Rettificato</b> 47,24"x47,24"	6,5 mm	Natural	PNT101	PNT100	PNT099	PNT098	PNT097
 <b>60x120 Rettificato</b> 23,62"x47,24"	8,5 mm	Natural	PNT267	PNT268	PNT269	PNT270	PNT271
	10 mm •	Natural	PNT065	PNT004	PNT003	PNT002	PNT001
 <b>30x120 Rettificato</b> 11,81"x47,24"	8,5 mm	Natural	PNT272	PNT273	PNT274	PNT275	PNT276
	10 mm •	Natural	PNT066	PNT058	PNT057	PNT056	PNT055
 <b>20x120 Rettificato</b> 7,87"x47,24"	8,5 mm	Natural	PNT277	PNT278	PNT279	PNT0280	PNT281
	10 mm •	Natural	PNT067	PNT008	PNT007	PNT006	PNT005
 <b>80x80 Rettificato</b> 31,50"x31,50"	8,5 mm	Natural	PNT297	PNT298	PNT299	PNT300	PNT301
	10 mm •	Natural	PNT085	PNT084	PNT083	PNT082	PNT081
	2 cm 2.OUT	Grip	PNT176	PNT178	PNT177	PNT179	-
 <b>60x60 Rettificato</b> 23,62"x23,62"	8,5 mm	Natural	PNT282	PNT283	PNT284	PNT285	PNT286
	10 mm •	Natural	PNT068	PNT012	PNT011	PNT010	PNT009
 <b>30x60 Rettificato</b> 11,81"x23,62"	8,5 mm	Natural	PNT287	PNT288	PNT289	PNT290	PNT291
	10 mm •	Natural	PNT070	PNT020	PNT019	PNT018	PNT017
 <b>30x30 mosaico (36 pcs)</b> 11,81"x11,81"	8,5 mm	Natural	PNT071A	PNT024A	PNT023A	PNT022A	PNT021A
	10 mm •	Natural	PNT071	PNT024	PNT023	PNT022	PNT021

• Disponibile fino ad esaurimento scorte | Available while stocks last | Disponible jusqu'à épuisement des stocks | Verfügbar solange der Vorrat reicht

pz / box	m² / box	kg / box	box / pallet	m² / pallet	kg / pallet	m² x pcs.	kg / m²	kg / crate	total kg	dimensione esterna cassa crate overall dimensions	codice prezzo price code
1	-	15,30								solo scatole complete   complete boxes only   à la boîte complète   nur kartonsweise	● PF013
1	-	15,30								solo scatole complete   complete boxes only   à la boîte complète   nur kartonsweise	● PF022
1	-	15,30								solo scatole complete   complete boxes only   à la boîte complète   nur kartonsweise	● PF022
2	-	30,50								solo scatole complete   complete boxes only   à la boîte complète   nur kartonsweise	● PF034
1	-	17,20								solo scatole complete   complete boxes only   à la boîte complète   nur kartonsweise	● PF010
1	-	18,12								solo scatole complete   complete boxes only   à la boîte complète   nur kartonsweise	● PF018
1	-	18,12								solo scatole complete   complete boxes only   à la boîte complète   nur kartonsweise	● PF018













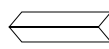
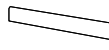

pz / box	m² / box	kg / box	box / pallet	m² / pallet	kg / pallet	m² x pcs.	kg / m²	kg / crate	total kg	dimensione esterna cassa crate overall dimensions	codice prezzo price code
1	3,33	51,61	18	59,94	929,00	3,33	15,50	101	1030,00	291x134x31,5 cm	■ MF017
2	2,88	44,64	20	57,60	892,80	1,44	15,50	54	946,80	130,2x130,2x40 cm	■ MF013
2	1,44	27,99	32	46,08	895,68	-	-	-	-	-	■ MF004
2	1,44	31,10	32	46,08	995,00	-	-	-	-	-	■ MF004
3	1,08	20,30	45	48,60	914,00	-	-	-	-	-	■ MF007
4	1,44	31,10	36	51,84	1120,00	-	-	-	-	-	■ MF007
4	0,96	18,05	60	57,60	1082,00	-	-	-	-	-	■ MF007
5	1,20	25,92	48	57,60	1244,00	-	-	-	-	-	■ MF007
2	1,28	23,30	50	64,00	1165,00	-	-	-	-	-	■ MF005
2	1,28	28,50	50	64,00	1425,00	-	-	-	-	-	■ MF005
1	0,64	30,53	40	25,60	1221,00	-	-	-	-	-	■ MF015
3	1,08	20,30	40	43,20	812,00	-	-	-	-	-	■ MF002
3	1,08	23,32	40	43,20	933,00	-	-	-	-	-	■ MF002
7	1,26	23,69	48	60,48	1137,00	-	-	-	-	-	■ MF001
6	1,08	26,00	40	43,20	933,00	-	-	-	-	-	■ MF001
6	-	10,00								solo scatole complete   complete boxes only   à la boîte complète   nur kartonsweise	● PF001
6	-	11,70								solo scatole complete   complete boxes only   à la boîte complète   nur kartonsweise	● PF001

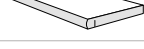
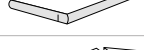

# codici prezzo e imballi

Price and packaging codes | Codes prix et emballages | Codes für Preis und Verpackungen

## planeto

formato size	spessore thickness	superfici surfaces	colori colors					
			VENUS	MOON	MARS	JUPITER	PLUTO	
	30x26 esagone 11,81"x10,24"	8,5 mm	Natural	PNT072A	PNT034A	PNT033A	PNT032A	PNT031A
	10 mm •	Natural	PNT072	PNT034	PNT033	PNT032	PNT031	
	30x30 basket 11,81"x11,81"	8,5 mm	Natural	PNT073A	PNT064A	PNT063A	PNT026A	PNT025A
	10 mm •	Natural	PNT073	PNT064	PNT063	PNT026	PNT025	
	30x30 scraps 11,81"x11,81"	8,5 mm	Natural	PNT074A	PNT030A	PNT029A	PNT028A	PNT027A
	10 mm •	Natural	PNT074	PNT030	PNT029	PNT028	PNT027	
	10x60 chevron 3,94"x23,62"	8,5 mm	Natural	PNT302	PNT303	PNT304	PNT305	PNT306
	10 mm •	Natural	PNT075	PNT038	PNT037	PNT036	PNT035	
	8x120 battiscopa 3,15"x47,24"	6,5 mm	Natural	PNT116	PNT115	PNT114	PNT113	PNT112
	8x120 battiscopa 3,15"x47,24"	8,5 mm	Natural	PNT077A	PNT046A	PNT045A	PNT044A	PNT043A
		10 mm •	Natural	PNT077	PNT046	PNT045	PNT044	PNT043
	8x60 battiscopa 3,15"x23,62"	8,5 mm	Natural	PNT079A	PNT0042A	PNT041A	PNT040A	PNT039A
10 mm •		Natural	PNT079	PNT042	PNT041	PNT040	PNT039	
	33x120x5 gradino lineare LL 12,99"x47,24"x1,97"	6,5 mm	Natural	PNT121	PNT120	PNT119	PNT118	PNT117
	33x120x5 gradino lineare M 12,99"x47,24"x1,97"	8,5 mm	Natural	PNT078A	PNT050A	PNT049A	PNT048A	PNT047A
10 mm •		Natural	PNT078	PNT050	PNT049	PNT048	PNT047	
	33x120x5 gradino angolare LL 12,99"x47,24"x1,97"	6,5 mm	Natural	PNT126	PNT125	PNT124	PNT123	PNT122
	33x120x5 gradino angolare M 12,99"x47,24"x1,97"	8,5 mm	Natural	PNT076A	PNT054A	PNT053A	PNT052A	PNT051A
10 mm •		Natural	PNT076	PNT054	PNT053	PNT052	PNT051	
	40x80x2 gradone toro lineare 15,75"x31,50"x0,78"	2 cm 2.OUT	Grip	PNT183	PNT221	PNT202	PNT240	-
	40x80x2 gradone toro angolare dx 15,75"x31,50"x0,78"	2 cm 2.OUT	Grip	PNT184	PNT222	PNT203	PNT241	-
	40x80x2 gradone toro angolare sx 15,75"x31,50"x0,78"	2 cm 2.OUT	Grip	PNT185	PNT223	PNT204	PNT242	-
	40x80x2 comp. gradone toro angolare interno 15,75"x31,50"x0,78"	2 cm 2.OUT	Grip	PNT186	PNT224	PNT205	PNT243	-
	40x80x2 gradone toro lineare nodrip 15,75"x31,50"x0,78"	2 cm 2.OUT	Grip	PNT187	PNT225	PNT206	PNT244	-
	40x80x2 gradone toro angolare dx nodrip 15,75"x31,50"x0,78"	2 cm 2.OUT	Grip	PNT188	PNT226	PNT207	PNT245	-
	40x80x2 gradone toro angolare sx nodrip 15,75"x31,50"x0,78"	2 cm 2.OUT	Grip	PNT189	PNT227	PNT208	PNT246	-
	40x80x2 comp. gradone toro angolare interno nodrip 15,75"x31,50"x0,78"	2 cm 2.OUT	Grip	PNT190	PNT228	PNT209	PNT247	-
	40x80x2 gradone cover lineare 15,75"x31,50"x0,78"	2 cm 2.OUT	Grip	PNT194	PNT232	PNT213	PNT251	-
	40x80x2 gradone cover angolare dx 15,75"x31,50"x0,78"	2 cm 2.OUT	Grip	PNT195	PNT233	PNT214	PNT252	-

• Disponibile fino ad esaurimento scorte | Available while stocks last | Disponible jusqu'à épuisement des stocks | Verfügbar solange der Vorrat reicht

pz / box	m² / box	kg / box	box / pallet	m² / pallet	kg / pallet	m² x pcs.	kg / m²	kg / crate	total kg	dimensione esterna cassa crate overall dimensions	codice prezzo price code
6	-	10,00									● PF006
6	-	10,00								solo scatole complete   complete boxes only   à la boîte complète   nur kartonsweise	
6	-	10,00								solo scatole complete   complete boxes only   à la boîte complète   nur kartonsweise	● PF003
6	-	11,70								solo scatole complete   complete boxes only   à la boîte complète   nur kartonsweise	● PF005
6	-	10,00								solo scatole complete   complete boxes only   à la boîte complète   nur kartonsweise	● PF006
6	-	11,70								solo scatole complete   complete boxes only   à la boîte complète   nur kartonsweise	● PF005
20	1,00	18,80								solo scatole complete   complete boxes only   à la boîte complète   nur kartonsweise	■ MF018
20	-	21,60								solo scatole complete   complete boxes only   à la boîte complète   nur kartonsweise	■ MF018
7	-	10,50								solo scatole complete   complete boxes only   à la boîte complète   nur kartonsweise	● PF004
6	-	10,40								solo scatole complete   complete boxes only   à la boîte complète   nur kartonsweise	● PF004
7	-	14,49								solo scatole complete   complete boxes only   à la boîte complète   nur kartonsweise	● PF004
11	-	9,50								solo scatole complete   complete boxes only   à la boîte complète   nur kartonsweise	● PF002
8	-	8,24								solo scatole complete   complete boxes only   à la boîte complète   nur kartonsweise	● PF002
2	-	15,00								solo scatole complete   complete boxes only   à la boîte complète   nur kartonsweise	● PF030
1	-	8,55								solo scatole complete   complete boxes only   à la boîte complète   nur kartonsweise	● PF030
1	-	8,55								solo scatole complete   complete boxes only   à la boîte complète   nur kartonsweise	● PF030
1	-	7,50								solo scatole complete   complete boxes only   à la boîte complète   nur kartonsweise	● PF032
1	-	8,55								solo scatole complete   complete boxes only   à la boîte complète   nur kartonsweise	● PF032
1	-	8,55								solo scatole complete   complete boxes only   à la boîte complète   nur kartonsweise	● PF032
1	-	15,30								solo scatole complete   complete boxes only   à la boîte complète   nur kartonsweise	● PF009
1	-	15,30								solo scatole complete   complete boxes only   à la boîte complète   nur kartonsweise	● PF014
1	-	15,30								solo scatole complete   complete boxes only   à la boîte complète   nur kartonsweise	● PF014
2	-	30,50								solo scatole complete   complete boxes only   à la boîte complète   nur kartonsweise	● PF037
1	-	15,30								solo scatole complete   complete boxes only   à la boîte complète   nur kartonsweise	● PF011
1	-	15,30								solo scatole complete   complete boxes only   à la boîte complète   nur kartonsweise	● PF016
1	-	15,30								solo scatole complete   complete boxes only   à la boîte complète   nur kartonsweise	● PF016
2	-	30,50								solo scatole complete   complete boxes only   à la boîte complète   nur kartonsweise	● PF029
1	-	15,30								solo scatole complete   complete boxes only   à la boîte complète   nur kartonsweise	● PF012
1	-	15,30								solo scatole complete   complete boxes only   à la boîte complète   nur kartonsweise	● PF019

606 TECH INFO





607 TECH INFO





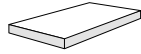
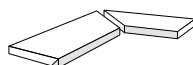
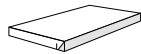
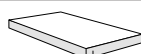

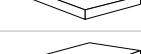

# codici prezzo e imballi

Price and packaging codes | Codes prix et emballages | Codes für Preis und Verpackungen

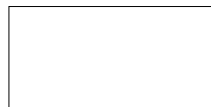
## planeto

formato size	spessore thickness	superfici surfaces	colori colors				
			VENUS	MOON	MARS	JUPITER	PLUTO
 <b>40x80x2 gradone cover angolare sx</b> 15,75"x31,50"x0,78"	2 cm 2.OUT	Grip	PNT196	PNT234	PNT215	PNT253	-
 <b>40x80x2 comp. gradone cover angolare interno</b> 15,75"x31,50"x0,78"	2 cm 2.OUT	Grip	PNT197	PNT235	PNT216	PNT254	-
 <b>40x80x2 gradone cover lineare nodrip</b> 15,75"x31,50"x0,78"	2 cm 2.OUT	Grip	PNT198	PNT236	PNT217	PNT255	-
 <b>40x80x2 gradone cover angolare dx nodrip</b> 15,75"x31,50"x0,78"	2 cm 2.OUT	Grip	PNT199	PNT237	PNT218	PNT256	-
 <b>40x80x2 gradone cover angolare sx nodrip</b> 15,75"x31,50"x0,78"	2 cm 2.OUT	Grip	PNT200	PNT238	PNT219	PNT257	-
 <b>40x80x2 comp. gradone cover angolare interno nodrip</b> 15,75"x31,50"x0,78"	2 cm 2.OUT	Grip	PNT201	PNT239	PNT220	PNT258	-
 <b>40x80x5 elemento L lineare</b> 15,75"x31,50"x1,97"	2 cm 2.OUT	Grip	PNT191	PNT229	PNT210	PNT248	-
 <b>40x80x5 elemento L angolare dx</b> 15,75"x31,50"x1,97"	2 cm 2.OUT	Grip	PNT192	PNT230	PNT211	PNT249	-
 <b>40x80x5 elemento L angolare sx</b> 15,75"x31,50"x1,97"	2 cm 2.OUT	Grip	PNT193	PNT231	PNT212	PNT250	-

## portland

formato size	spessore thickness	superfici surfaces	colori colors				
			JORDAN	HOOD	TABOR	HELEN	LASSEN
 <b>160x320 Rettificato</b> • 62,99"x125,98"	6,5 mm	Natural	PTL099	PTL091	PTL095	-	-
 <b>120x278 Rettificato</b> 47,24"x109,45"	6,5 mm	Natural	PTL215	PTL216	PTL217	PTL218	PTL219
 <b>120x120 Rettificato</b> 47,24"x47,24"	6,5 mm	Natural	PTL057	PTL004	PTL012	PTL020	PTL028
 <b>60x120 Rettificato</b> 23,62"x47,24"	6,5 mm	Natural	PTL170	PTL169	PTL171	PTL172	PTL173
	8,5 mm	Natural	PTL368	PTL367	PTL369	-	-
	10 mm ••	Natural	PTL110	PTL104	PTL107	-	-
 <b>80x80 Rettificato</b> 31,50"x31,50"	8,5 mm	Natural	PTL372	PTL371	PTL374	PTL370	PTL373
	10 mm ••	Natural	PTL117	PTL206	PTL208	PTL205	PTL207
	2 cm 2.OUT	Grip	PTL299	PTL298	-	-	PTL300
 <b>40x80 Rettificato</b> 15,75"x31,50"	8,5 mm	Natural	PTL384	PTL383	PTL386	PTL382	PTL385
	10 mm ••	Natural	PTL118	PTL198	PTL200	PTL197	PTL199

- Disponibile su richiesta | Available on request | Disponible sur demande | Auf Anfrage erhältlich
- Disponibile fino ad esaurimento scorte | Available while stocks last | Disponible jusqu'à épuisement des stocks | Verfügbar solange der Vorrat reicht

pz / box	m² / box	kg / box	box / pallet	m² / pallet	kg / pallet	m² x pcs.	kg / m²	kg / crate	total kg	dimensione esterna cassa crate overall dimensions	codice prezzo price code
1	-	15,30								solo scatole complete   complete boxes only   à la boîte complète   nur kartonsweise	● PF019
2	-	30,50								solo scatole complete   complete boxes only   à la boîte complète   nur kartonsweise	● PF033
1	-	15,30								solo scatole complete   complete boxes only   à la boîte complète   nur kartonsweise	● PF013
1	-	15,30								solo scatole complete   complete boxes only   à la boîte complète   nur kartonsweise	● PF022
1	-	15,30								solo scatole complete   complete boxes only   à la boîte complète   nur kartonsweise	● PF022
2	-	30,50								solo scatole complete   complete boxes only   à la boîte complète   nur kartonsweise	● PF034
1	-	17,20								solo scatole complete   complete boxes only   à la boîte complète   nur kartonsweise	● PF010
1	-	18,12								solo scatole complete   complete boxes only   à la boîte complète   nur kartonsweise	● PF018
1	-	18,12								solo scatole complete   complete boxes only   à la boîte complète   nur kartonsweise	● PF018











pz / box	m² / box	kg / box	box / pallet	m² / pallet	kg / pallet	m² x pcs.	kg / m²	kg / crate	total kg	dimensione esterna cassa crate overall dimensions	codice prezzo price code
1	5,12	79,36	14	71,68	1111,00	5,12	15,50	153	1264,00	343,2x172,6x36,2 cm	■ MF025
1	3,33	51,61	18	59,94	929,00	3,33	15,50	101	1030,00	291x134x31,5 cm	■ MF017
2	2,88	44,64	20	57,60	893,00	1,44	15,50	54	946,80	130,2x130,2x40 cm	■ MF012
2	1,44	22,32	40	57,60	893,00	-	-	-	-	-	■ MF011
2	1,44	27,99	32	46,08	895,68	-	-	-	-	-	■ MF004
2	1,44	31,10	32	46,08	995,00	-	-	-	-	-	■ MF005
2	1,28	23,30	50	64,00	1165,00	-	-	-	-	-	■ MF005
2	1,28	28,50	50	64,00	1425,00	-	-	-	-	-	■ MF005
1	0,64	30,53	40	25,60	1221,00	-	-	-	-	-	■ MF015
3	0,96	18,20	36	34,56	655,00	-	-	-	-	-	■ MF003
4	1,28	27,64	48	61,44	1327,00	-	-	-	-	-	■ MF003

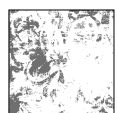
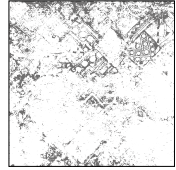

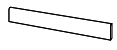
# codici prezzo e imballi

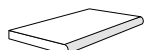
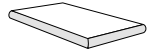
Price and packaging codes | Codes prix et emballages | Codes für Preis und Verpackungen

## portland

formato size	spessore thickness	superfici surfaces	colori colors				
			JORDAN	HOOD	TABOR	HELEN	LASSEN
	60x60 Rettificato 23,62"x23,62"	Natural	-	PTL388	PTL390	PTL387	PTL389
	10 mm ●●	Natural	-	PTL179	PTL185	PTL181	PTL183
	30x60 Rettificato 11,81"x23,62"	Natural	-	PTL396	PTL398	PTL395	PTL397
	10 mm ●●	Natural	-	PTL180	PTL193	PTL191	PTL192
	80x80 decorato 31,50"x31,50"	Natural	-	PTL376	PTL378	PTL375	PTL377
	10 mm ●●	Natural	-	PTL202	PTL204	PTL201	PTL203
	60x60 decorato 23,62"x23,62"	Natural	-	PTL392	PTL394	PTL391	PTL393
	10 mm ●●	Natural	-	PTL178	PTL186	PTL182	PTL184
	120x120 decoro Mood 47,24"x47,24"	Natural	-	PTL034	PTL036	PTL038	PTL040
	30x60 mix size 11,81"x23,62"	Natural	-	PTL400	PTL402	PTL399	PTL401
	10 mm ●●	Natural	-	PTL267	PTL269	PTL266	PTL268
	30x30 mosaico (36 pcs) 11,81"x11,81"	Natural	-	PTL271A	PTL273A	PTL270A	PTL272A
	10 mm ●●	Natural	-	PTL271	PTL273	PTL270	PTL272
	8x120 battiscopa 3,15"x47,24"	Natural	PTL111	PTL008	PTL016	PTL024	PTL032
	8x80 battiscopa 3,15"x31,50"	Natural	PTL143A	PTL275A	PTL277A	PTL274A	PTL276A
		10 mm ●●	Natural	PTL143	PTL275	PTL277	PTL274
	8x60 battiscopa 3,15"x23,62"	Natural	-	PTL279A	PTL281A	PTL278A	PTL280A
10 mm ●●		Natural	-	PTL279	PTL281	PTL278	PTL280
	33x120x5 gradino lineare LL 12,99"x47,24"x1,97"	Natural	PTL112	PTL006	PTL014	PTL022	PTL030
	40x80x5 gradino lineare M 15,75"x31,50"x1,97"	Natural	-	PTL283A	PTL285A	PTL282A	PTL284A
10 mm ●●		Natural	-	PTL283	PTL285	PTL282	PTL284
	33x120x5 gradino angolare LL 12,99"x47,24"x1,97"	Natural	PTL113	PTL007	PTL015	PTL023	PTL031
	40x80x5 gradino angolare M 15,75"x31,50"x1,97"	Natural	-	PTL287A	PTL289A	PTL286A	PTL288A
		10 mm ●●	Natural	-	PTL287	PTL289	PTL286
	40x80x2 gradone toro lineare 15,75"x31,50"x0,78"	Grip	PTL321	PTL303	-	-	PTL340
	40x80x2 gradone toro angolare dx 15,75"x31,50"x0,78"	Grip	PTL322	PTL304	-	-	PTL341
	40x80x2 gradone toro angolare sx 15,75"x31,50"x0,78"	Grip	PTL323	PTL305	-	-	PTL342
	40x80x2 comp. gradone toro angolare interno 15,75"x31,50"x0,78"	Grip	PTL324	PTL302	-	-	PTL343
	40x80x2 gradone toro lineare nodrip 15,75"x31,50"x0,78"	Grip	PTL325	PTL306	-	-	PTL344

●● Disponibile fino ad esaurimento scorte | Available while stocks last | Disponible jusqu'à épuisement des stocks | Verfügbar solange der Vorrat reicht

pz / box	m² / box	kg / box	box / pallet	m² / pallet	kg / pallet	m² x pcs.	kg / m²	kg / crate	total kg	dimensione esterna cassa crate overall dimensions	codice prezzo price code
3	1,08	20,30	40	43,20	812,00	-	-	-	-	-	MF002
3	1,08	23,32	40	43,20	933,00	-	-	-	-	-	MF001
7	1,26	23,69	48	60,48	1137,00	-	-	-	-	-	MF001
6	1,08	26,00	40	43,20	1040,00	-	-	-	-	-	MF001
2	1,28	23,30	50	64,00	1165,00	-	-	-	-	-	MF007
2	1,28	28,50	50	51,20	1425,00	-	-	-	-	-	MF007
3	1,08	20,30	40	43,20	812,00	-	-	-	-	-	MF006
3	1,08	23,20	40	43,20	920,00	-	-	-	-	-	MF006
2	2,88	44,64	20	57,60	893,00	1,44	15,50	54	946,80	130,2x130,2x40 cm	MF014
5	0,90	16,92	48	43,20	812,00	-	-	-	-	-	MF023
5	0,90	21,28	48	43,20	1021,00	-	-	-	-	-	MF023
6	0,54	10,00	solo scatole complete   complete boxes only   à la boîte complète   nur kartonsweise								PF002
6	0,54	12,78	solo scatole complete   complete boxes only   à la boîte complète   nur kartonsweise								PF002
7	-	10,50	solo scatole complete   complete boxes only   à la boîte complète   nur kartonsweise								PF004
8	-	9,28	solo scatole complete   complete boxes only   à la boîte complète   nur kartonsweise								PF002
6	-	9,60	solo scatole complete   complete boxes only   à la boîte complète   nur kartonsweise								PF002
11	-	9,50	solo scatole complete   complete boxes only   à la boîte complète   nur kartonsweise								PF002
8	-	9,60	solo scatole complete   complete boxes only   à la boîte complète   nur kartonsweise								PF002
2	-	15,00	solo scatole complete   complete boxes only   à la boîte complète   nur kartonsweise								PF030
2	-	15,00	solo scatole complete   complete boxes only   à la boîte complète   nur kartonsweise								PF023
2	-	15,00	solo scatole complete   complete boxes only   à la boîte complète   nur kartonsweise								PF023
1	-	7,50	solo scatole complete   complete boxes only   à la boîte complète   nur kartonsweise								PF032
1	-	15,00	solo scatole complete   complete boxes only   à la boîte complète   nur kartonsweise								PF024
1	-	15,00	solo scatole complete   complete boxes only   à la boîte complète   nur kartonsweise								PF024
1	-	15,30	solo scatole complete   complete boxes only   à la boîte complète   nur kartonsweise								PF009
1	-	15,30	solo scatole complete   complete boxes only   à la boîte complète   nur kartonsweise								PF014
1	-	15,30	solo scatole complete   complete boxes only   à la boîte complète   nur kartonsweise								PF014
2	-	30,50	solo scatole complete   complete boxes only   à la boîte complète   nur kartonsweise								PF037
1	-	15,30	solo scatole complete   complete boxes only   à la boîte complète   nur kartonsweise								PF011



# codici prezzo e imballi

Price and packaging codes | Codes prix et emballages | Codes für Preis und Verpackungen

## portland

formato size	spessore thickness	superfici surfaces	colori colors				
			JORDAN	HOOD	TABOR	HELEN	LASSEN
 40x80x2 gradone toro angolare dx nodrip 15,75"x31,50"x0,78"	2 cm 2.OUT	Grip	PTL326	PTL307	-	-	PTL345
 40x80x2 gradone toro angolare sx nodrip 15,75"x31,50"x0,78"	2 cm 2.OUT	Grip	PTL327	PTL308	-	-	PTL346
 40x80x2 comp. gradone toro angolare interno nodrip 15,75"x31,50"x0,78"	2 cm 2.OUT	Grip	PTL328	PTL309	-	-	PTL347
 40x80x2 gradone cover lineare 15,75"x31,50"x0,78"	2 cm 2.OUT	Grip	PTL332	PTL313	-	-	PTL351
 40x80x2 gradone cover angolare dx 15,75"x31,50"x0,78"	2 cm 2.OUT	Grip	PTL333	PTL314	-	-	PTL352
 40x80x2 gradone cover angolare sx 15,75"x31,50"x0,78"	2 cm 2.OUT	Grip	PTL334	PTL315	-	-	PTL353
 40x80x2 comp. gradone cover angolare interno 15,75"x31,50"x0,78"	2 cm 2.OUT	Grip	PTL335	PTL316	-	-	PTL354
 40x80x2 gradone cover lineare nodrip 15,75"x31,50"x0,78"	2 cm 2.OUT	Grip	PTL336	PTL317	-	-	PTL355
 40x80x2 gradone cover angolare dx nodrip 15,75"x31,50"x0,78"	2 cm 2.OUT	Grip	PTL337	PTL318	-	-	PTL356
 40x80x2 gradone cover angolare sx nodrip 15,75"x31,50"x0,78"	2 cm 2.OUT	Grip	PTL338	PTL319	-	-	PTL357
 40x80x2 comp. gradone cover angolare interno nodrip 15,75"x31,50"x0,78"	2 cm 2.OUT	Grip	PTL339	PTL320	-	-	PTL358
 40x80x5 elemento L lineare 15,75"x31,50"x1,97"	2 cm 2.OUT	Grip	PTL329	PTL310	-	-	PTL348
 40x80x5 elemento L angolare dx 15,75"x31,50"x1,97"	2 cm 2.OUT	Grip	PTL330	PTL311	-	-	PTL349
 40x80x5 elemento L angolare sx 15,75"x31,50"x1,97"	2 cm 2.OUT	Grip	PTL331	PTL312	-	-	PTL350

## reframe

formato size	spessore thickness	superfici surfaces	colori colors		
			IVORY	TAUPE	GRAPHITE
 120x278 Rettificato 47,24"x109,45"	6,5 mm	Natural	REF038	REF037	REF039
 120x120 Rettificato 47,24"x47,24"	6,5 mm	Natural	REF005	REF004	REF006
 60x120 Rettificato 23,62"x47,24"	8,5 mm	Natural	REF089	REF090	REF091
	10 mm •	natural	REF008	REF007	REF009

• Disponibile fino ad esaurimento scorte | Available while stocks last | Disponible jusqu'à épuisement des stocks | Verfügbar solange der Vorrat reicht

pz / box	m <sup>2</sup> / box	kg / box	box / pallet	m <sup>2</sup> / pallet	kg / pallet	m <sup>2</sup> x pcs.	kg / m <sup>2</sup>	kg / crate	total kg	dimensione esterna cassa crate overall dimensions	codice prezzo price code
1	-	15,30								solo scatole complete   complete boxes only   à la boîte complète   nur kartonsweise	● PF016
1	-	15,30								solo scatole complete   complete boxes only   à la boîte complète   nur kartonsweise	● PF016
2	-	30,50								solo scatole complete   complete boxes only   à la boîte complète   nur kartonsweise	● PF029
1	-	15,30								solo scatole complete   complete boxes only   à la boîte complète   nur kartonsweise	● PF012
1	-	15,30								solo scatole complete   complete boxes only   à la boîte complète   nur kartonsweise	● PF019
1	-	15,30								solo scatole complete   complete boxes only   à la boîte complète   nur kartonsweise	● PF019
2	-	30,50								solo scatole complete   complete boxes only   à la boîte complète   nur kartonsweise	● PF033
1	-	15,30								solo scatole complete   complete boxes only   à la boîte complète   nur kartonsweise	● PF013
1	-	15,30								solo scatole complete   complete boxes only   à la boîte complète   nur kartonsweise	● PF022
1	-	15,30								solo scatole complete   complete boxes only   à la boîte complète   nur kartonsweise	● PF022
2	-	30,50								solo scatole complete   complete boxes only   à la boîte complète   nur kartonsweise	● PF034
1	-	17,20								solo scatole complete   complete boxes only   à la boîte complète   nur kartonsweise	● PF010
1	-	18,12								solo scatole complete   complete boxes only   à la boîte complète   nur kartonsweise	● PF018
1	-	18,12								solo scatole complete   complete boxes only   à la boîte complète   nur kartonsweise	● PF018









pz / box	m <sup>2</sup> / box	kg / box	box / pallet	m <sup>2</sup> / pallet	kg / pallet	m <sup>2</sup> x pcs.	kg / m <sup>2</sup>	kg / crate	total kg	dimensione esterna cassa crate overall dimensions	codice prezzo price code
1	3,33	51,61	18	59,94	929,00	3,33	15,50	101	929,00	291x134x31,5 cm	■ MF017
2	2,88	44,64	20	57,60	892,80	1,44	15,50	54	946,80	130,2x130,2x40 cm	■ MF012
2	1,44	27,99	32	46,08	895,68	-	-	-	-	-	■ MF004
2	1,44	31,10	32	46,08	995,00	-	-	-	-	-	



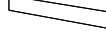

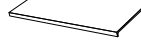

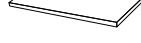



# codici prezzo e imballi

Price and packaging codes | Codes prix et emballages | Codes für Preis und Verpackungen

## reframe

formato size	spessore thickness	superfici surfaces	colori colors		
			IVORY	TAUPE	GRAPHITE
	8,5 mm	Natural	REF092	REF093	REF094
	10 mm •	Natural	REF011	REF010	REF012
	8,5 mm	Natural	REF095	REF096	REF097
	10 mm •	Natural	REF014	REF013	REF015
	6,5 mm	Natural	REF017	REF016	REF018
	8,5 mm	Natural	REF026A	REF025A	REF027A
	10 mm •	Natural	REF026	REF025	REF027
	6,5 mm	Natural	REF020	REF019	REF021
	8,5 mm	Natural	REF029A	REF028A	REF030A
	10 mm •	Natural	REF029	REF028	REF030
	6,5 mm	Natural	REF023	REF022	REF024
	8,5 mm	Natural	REF032A	REF031A	REF033A
	10 mm •	Natural	REF032	REF031	REF033
	8,5 mm	Natural	REF032A	REF031A	REF033A
	10 mm •	Natural	REF032	REF031	REF033
	8,5 mm	Natural	REF032A	REF031A	REF033A

## res art

formato size	spessore thickness	superfici surfaces	colori colors									
			TALC	ASH	POWDER	MUD	LAVA	POTTERY	OLIVE	AVIO	CAMEO	
	6,5 mm	Natural	RES217	RES218	RES219	RES220	RES221	RES222	RES238	RES239	RES295	
	6,5 mm	Natural	RES178	RES179	RES180	RES181	RES182	RES183	RES232	RES233	RES292	
	6,5 mm	Natural	RES192	RES193	RES194	RES195	RES196	RES197	RES234	RES235	RES293	
	6,5 mm	Natural	RES259	RES260	RES261	RES262	RES263	RES264	RES266	RES267	RES300	
	6,5 mm	Natural	RES171	RES172	RES173	RES174	RES175	RES176	RES254	RES255	RES299	
	6,5 mm	Natural	RES199	RES200	RES201	RES202	RES203	RES204	RES248	RES249	RES296	
	6,5 mm	Natural	RES078	RES079	RES080	RES081	RES082	RES206	RES250	RES251	RES297	
	6,5 mm	Natural	RES085	RES086	RES087	RES088	RES089	RES207	RES252	RES253	RES298	

pz / box	m² / box	kg / box	box / pallet	m² / pallet	kg / pallet	m² x pcs.	kg / m²	kg / crate	total kg	dimensione esterna cassa crate overall dimensions	codice prezzo price code	
2	1,28	23,30	50	64,00	1165,00	-	-	-	-	-	MF005	
2	1,28	28,50	50	64,00	1425,00	-	-	-	-	-	MF003	
3	0,96	17,47	36	34,26	655,00	-	-	-	-	-	MF003	
4	1,28	27,94	48	61,44	1327,00	-	-	-	-	-	MF003	
7	-	10,50	solo scatole complete   complete boxes only   à la boîte complète   nur kartonsweise									PF004
8	-	9,28	solo scatole complete   complete boxes only   à la boîte complète   nur kartonsweise									PF002
6	-	9,60										
2	-	15,00	solo scatole complete   complete boxes only   à la boîte complète   nur kartonsweise									PF030
2	-	15,00	solo scatole complete   complete boxes only   à la boîte complète   nur kartonsweise									PF023
2	-	15,00	solo scatole complete   complete boxes only   à la boîte complète   nur kartonsweise									PF023
1	-	7,50	solo scatole complete   complete boxes only   à la boîte complète   nur kartonsweise									PF032
1	-	7,50	solo scatole complete   complete boxes only   à la boîte complète   nur kartonsweise									PF024
1	-	7,50										



pz / box	m² / box	kg / box	box / pallet	m² / pallet	kg / pallet	m² x pcs.	kg / m²	kg / crate	total kg	dimensione esterna cassa crate overall dimensions	codice prezzo price code	
1	3,33	51,61	18	59,94	929,00	3,33	15,50	101	1030,00	291x134x31,5 cm	MF019	
2	2,88	44,64	20	57,60	892,80	1,44	15,50	54	946,80	130,2x130,2x40 cm	MF013	
2	1,44	22,32	40	57,60	893,00	-	-	-	-	-	MF011	
33	0,495	8,00	solo scatole complete   complete boxes only   à la boîte complète   nur kartonsweise									MF027
6	-	8,22	solo scatole complete   complete boxes only   à la boîte complète   nur kartonsweise									PF008
7	-	10,50	solo scatole complete   complete boxes only   à la boîte complète   nur kartonsweise									PF004
2	-	15,00	solo scatole complete   complete boxes only   à la boîte complète   nur kartonsweise									PF030
1	-	7,50	solo scatole complete   complete boxes only   à la boîte complète   nur kartonsweise									PF032



# codici prezzo e imballi

Price and packaging codes | Codes prix et emballages | Codes für Preis und Verpackungen

## royal travertino

formato size	spessore thickness	superfici surfaces	colori colors					
			EBUR VEIN	EBUR CROSS	NAVONA VEIN	NAVONA CROSS	GRISEO VEIN	GRISEO CROSS
 120x278 Rettificato 47,24"x109,45"	6,5 mm	Real Matt	ROT016	-	ROT017	-	ROT018	-
 120x120 Rettificato 47,24"x47,24"	6,5 mm	Real Matt	-	ROT004	-	ROT005	-	ROT006
 60x120 Rettificato 23,62"x47,24"	8,5 mm	Real Matt	ROT019	-	ROT020	-	ROT021	-
 80x80 Rettificato 31,50"x31,50"	8,5 mm	Real Matt	-	ROT025	-	ROT026	-	ROT027
 60x120 decoro Wavy 23,62"x47,24"	8,5 mm	Real Matt	ROT022	-	ROT023	-	ROT024	-
 8x120 battiscopa 3,15"x47,24"	6,5 mm	Real Matt	ROT028	ROT037	ROT029	ROT038	ROT030	ROT039
	8,5 mm	Real Matt	ROT055	-	ROT056	-	ROT057	-
 8x80 battiscopa 3,15"x31,50"	8,5 mm	Real Matt	-	ROT046	-	ROT047	-	ROT048
 33x120x5 gradino lineare LL 12,99"x47,24"x1,97"	6,5 mm	Real Matt	ROT031	ROT040	ROT032	ROT041	ROT033	ROT042
	8,5 mm	Real Matt	ROT058	-	ROT059	-	ROT060	-
 33x120x5 gradino lineare M 12,99"x47,24"x1,97"	8,5 mm	Real Matt	ROT058	-	ROT059	-	ROT060	-
 40x80x5 gradino lineare M 15,75"x31,50"x1,97"	8,5 mm	Real Matt	-	ROT049	-	ROT050	-	ROT051
 33x120x5 gradino angolare LL 12,99"x47,24"x1,97"	6,5 mm	Real Matt	ROT034	ROT043	ROT035	ROT044	ROT036	ROT045
	8,5 mm	Real Matt	ROT061	-	ROT062	-	ROT063	-
 33x120x5 gradino angolare M 12,99"x47,24"x1,97"	8,5 mm	Real Matt	ROT061	-	ROT062	-	ROT063	-
 40x80x5 gradino angolare M 15,75"x31,50"x1,97"	8,5 mm	Real Matt	-	ROT052	-	ROT053	-	ROT054

## shards

formato size	spessore thickness	superfici surfaces	colori colors		
			LARGE WHITE	LARGE GREY	LARGE BLACK
 120x120 Rettificato 47,24"x47,24"	6,5 mm	Glossy	SHA030	SHA032	SHA031
		Natural	SHA078	SHA080	SHA079
 8x120 battiscopa 3,15"x47,24"	6,5 mm	Glossy	SHA033	SHA035	SHA034
		Natural	SHA081	SHA083	SHA082
 33x120x5 gradino lineare LL 12,99"x47,24"x1,97"	6,5 mm	Glossy	SHA036	SHA038	SHA037
		Natural	SHA084	SHA086	SHA085
 33x120x5 gradino angolare LL 12,99"x47,24"x1,97"	6,5 mm	Glossy	SHA039	SHA041	SHA040
		Natural	SHA087	SHA089	SHA088

pz / box	m² / box	kg / box	box / pallet	m² / pallet	kg / pallet	m² x pcs.	kg / m²	kg / crate	total kg	dimensione esterna cassa crate overall dimensions	codice prezzo price code
1	3,33	51,61	18	59,94	929,00	3,33	15,50	101	1030,00	291x134x31,5 cm	■ MF017
2	2,88	44,64	20	57,60	892,80	1,44	15,50	54	946,80	130,2x130,2x40 cm	■ MF012
2	1,44	28,00	32	46,08	911,00	-	-	-	-	-	■ MF004
2	1,28	23,29	50	64,00	1180,00	-	-	-	-	-	■ MF005
2	1,44	28,00	32	46,08	911,00	-	-	-	-	-	■ MF009
7	-	10,50	solo scatole complete   complete boxes only   à la boîte complète   nur kartonsweise								● PF004
6	-	11,40	solo scatole complete   complete boxes only   à la boîte complète   nur kartonsweise								● PF002
8	-	9,28	solo scatole complete   complete boxes only   à la boîte complète   nur kartonsweise								● PF030
2	-	15,00	solo scatole complete   complete boxes only   à la boîte complète   nur kartonsweise								● PF030
1	-	8,55	solo scatole complete   complete boxes only   à la boîte complète   nur kartonsweise								● PF023
2	-	11,64	solo scatole complete   complete boxes only   à la boîte complète   nur kartonsweise								● PF032
1	-	7,50	solo scatole complete   complete boxes only   à la boîte complète   nur kartonsweise								● PF032
2	-	7,70	solo scatole complete   complete boxes only   à la boîte complète   nur kartonsweise								● PF024
2	-	5,82	solo scatole complete   complete boxes only   à la boîte complète   nur kartonsweise								● PF024







pz / box	m² / box	kg / box	box / pallet	m² / pallet	kg / pallet	m² x pcs.	kg / m²	kg / crate	total kg	dimensione esterna cassa crate overall dimensions	codice prezzo price code
2	2,88	44,64	20	57,60	892,80	1,44	15,50	54	946,80	130,2x130,2x40 cm	■ MF024 ■ MF012
7	-	10,50	solo scatole complete   complete boxes only   à la boîte complète   nur kartonsweise								● PF007 ● PF004
2	-	15,00	solo scatole complete   complete boxes only   à la boîte complète   nur kartonsweise								● PF038 ● PF030
1	-	7,50	solo scatole complete   complete boxes only   à la boîte complète   nur kartonsweise								● PF040 ● PF032





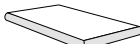

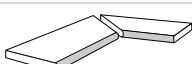
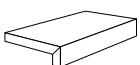
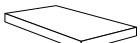

# codici prezzo e imballi

Price and packaging codes | Codes prix et emballages | Codes für Preis und Verpackungen

## stone lab

formato size	spessore thickness	superfici surfaces	colori colors	
			SILVER STONE	CEPPO
 <b>160x320 Rettificato</b> • 62,99"x125,98"	6,5 mm	Natural	STL049	-
 <b>100x100 Rettificato</b> 39,37"x39,37"	2 cm 2.OUT	Grip	-	STL058
 <b>40x100x2 gradone toro lineare</b> 15,75"x39,37"x0,78"	2 cm 2.OUT	Grip	-	STL065
 <b>40x100x2 gradone toro angolare dx</b> 15,75"x39,37"x0,78"	2 cm 2.OUT	Grip	-	STL066
 <b>40x100x2 gradone toro angolare sx</b> 15,75"x39,37"x0,78"	2 cm 2.OUT	Grip	-	STL067
 <b>40x100x2 comp. gradone toro angolare interno</b> 15,75"x39,37"x0,78"	2 cm 2.OUT	Grip	-	STL069
 <b>40x100x5 elemento L lineare</b> 15,75"x39,37"x1,97"	2 cm 2.OUT	Grip	-	STL068
 <b>40x100x5 elemento L angolare dx</b> 15,75"x39,37"x1,97"	2 cm 2.OUT	Grip	-	STL070
 <b>40x100x5 elemento L angolare sx</b> 15,75"x39,37"x1,97"	2 cm 2.OUT	Grip	-	STL071

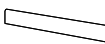
## urban craft

formato size	spessore thickness	superfici surfaces	colori colors			
			PLASTER	REDCLAY	CHARCOAL	CHROME
 <b>120x278 Rettificato</b> 47,24"x109,45"	6,5 mm	Natural	UBC007	UBC009	UBC008	UBC044
 <b>120x120 Rettificato</b> 47,24"x47,24"	6,5 mm	Natural	UBC010	UBC012	UBC011	UBC041
 <b>60x120 Rettificato</b> 23,62"x47,24"	6,5 mm	Natural	UBC037	UBC039	UBC038	UBC042
 <b>100x100 Rettificato</b> 31,50"x31,50"	2 cm 2.OUT	Grip	UBC058	-	-	-
 <b>8x120 battiscopa</b> 3,15"x47,24"	6,5 mm	Natural	UBC013	UBC015	UBC014	UBC045
 <b>33x120x5 gradino lineare LL</b> 12,99"x47,24"x1,97"	6,5 mm	Natural	UBC016	UBC018	UBC017	UBC046
 <b>33x120x5 gradino angolare LL</b> 12,99"x47,24"x1,97"	6,5 mm	Natural	UBC019	UBC021	UBC020	UBC047

• Disponibile su richiesta | Available on request | Disponible sur demande | Auf Anfrage erhältlich

pz / box	m² / box	kg / box	box / pallet	m² / pallet	kg / pallet	m² x pcs.	kg / m²	kg / crate	total kg	dimensione esterna cassa crate overall dimensions	codice prezzo price code
1	5,12	79,36	14	71,68	1111,00	5,12	15,50	153	1264,00	343,2x172,6x36,2 cm	■ MF025
1	1,00	44,00	24	24,00	1056,00	-	-	-	-	special pallet 103x103 cm	■ MF020
1	-	17,60	solo scatole complete   complete boxes only   à la boîte complète   nur kartonsweise								● PF017
1	-	17,60	solo scatole complete   complete boxes only   à la boîte complète   nur kartonsweise								● PF027
1	-	17,60	solo scatole complete   complete boxes only   à la boîte complète   nur kartonsweise								● PF027
2	-	35,20	solo scatole complete   complete boxes only   à la boîte complète   nur kartonsweise								● PF036
1	-	19,70	solo scatole complete   complete boxes only   à la boîte complète   nur kartonsweise								● PF020
1	-	19,70	solo scatole complete   complete boxes only   à la boîte complète   nur kartonsweise								● PF025
1	-	19,70	solo scatole complete   complete boxes only   à la boîte complète   nur kartonsweise								● PF025

pz / box	m² / box	kg / box	box / pallet	m² / pallet	kg / pallet	m² x pcs.	kg / m²	kg / crate	total kg	dimensione esterna cassa crate overall dimensions	codice prezzo price code
1	3,33	51,61	18	59,94	929,00	3,33	15,50	101	1030,00	291x134x31,5 cm	■ MF017
2	2,88	44,64	20	57,60	892,80	1,44	15,50	54	946,80	130,2x130,2x40 cm	■ MF012
2	1,44	22,32	40	57,60	893,00	-	-	-	-	-	■ MF011
1	1,00	44,00	24	24,00	1056,00	-	-	-	-	special pallet 103x103 cm	■ MF020
7	-	10,50	solo scatole complete   complete boxes only   à la boîte complète   nur kartonsweise								● PF004
2	-	15,00	solo scatole complete   complete boxes only   à la boîte complète   nur kartonsweise								● PF030
1	-	7,50	solo scatole complete   complete boxes only   à la boîte complète   nur kartonsweise								● PF032









# codici prezzo e imballi

Price and packaging codes | Codes prix et emballages | Codes für Preis und Verpackungen

## urban craft

formato size	spessore thickness	superfici surfaces	colori colors			
			PLASTER	REDCLAY	CHARCOAL	CHROME
 <b>40x100x2 gradone toro lineare</b> 15,75"x39,37"x0,78"	2 cm 2.OUT	Grip	UBC059	-	-	-
 <b>40x100x2 gradone toro angolare dx</b> 15,75"x39,37"x0,78"	2 cm 2.OUT	Grip	UBC060	-	-	-
 <b>40x100x2 gradone toro angolare sx</b> 15,75"x39,37"x0,78"	2 cm 2.OUT	Grip	UBC061	-	-	-
 <b>40x100x2 comp. gradone toro angolare interno</b> 15,75"x39,37"x0,78"	2 cm 2.OUT	Grip	UBC062	-	-	-
 <b>40x100x5 elemento L lineare</b> 15,75"x39,37"x1,97"	2 cm 2.OUT	Grip	UBC063	-	-	-
 <b>40x100x5 elemento L angolare dx</b> 15,75"x39,37"x1,97"	2 cm 2.OUT	Grip	UBC064	-	-	-
 <b>40x100x5 elemento L angolare sx</b> 15,75"x39,37"x1,97"	2 cm 2.OUT	Grip	UBC065	-	-	-

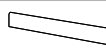
## upper

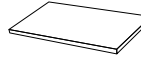
formato size	spessore thickness	superfici surfaces	colori colors			
			BUTTER	FOG	DOVE GREY	ELEPHANT GREY
 <b>120x278 Rettificato</b> 47,24"x109,45"	6,5 mm	Natural	UPP013	UPP015	UPP014	UPP016
 <b>120x120 Rettificato</b> 47,24"x47,24"	6,5 mm	Natural	UPP005	UPP007	UPP006	UPP008
 <b>60x120 Rettificato</b> 23,62"x47,24"	8,5 mm	Natural	UPP092	UPP094	UPP093	UPP095
 <b>100x100 Rettificato</b> 31,50"x31,50"	2 cm 2.OUT	Grip	-	UPP104	-	-
 <b>60x120 decoro Stick</b> 23,62"x47,24"	8,5 mm	Natural	UPP096	UPP098	UPP097	UPP099
 <b>8x120 battiscopa</b> 3,15"x47,24"	6,5 mm	Natural	UPP017	UPP019	UPP018	UPP020
<b>8x80 battiscopa</b> 3,15"x31,50"	8,5 mm	Natural	UPP053	UPP055	UPP054	UPP056
 <b>33x120x5 gradino lineare LL</b> 12,99"x47,24"x1,97"	6,5 mm	Natural	UPP021	UPP023	UPP022	UPP024
<b>40x80x5 gradino lineare M</b> 15,75"x31,50"x1,97"	8,5 mm	Natural	UPP057	UPP059	UPP058	UPP060
 <b>33x120x5 gradino angolare LL</b> 12,99"x47,24"x1,97"	6,5 mm	Natural	UPP025	UPP027	UPP026	UPP028
<b>40x80x5 gradino angolare M</b> 15,75"x31,50"x1,97"	8,5 mm	Natural	UPP061	UPP063	UPP062	UPP064

pz / box	m² / box	kg / box	box / pallet	m² / pallet	kg / pallet	m² x pcs.	kg / m²	kg / crate	total kg	dimensione esterna cassa crate overall dimensions	codice prezzo price code
1	-	17,60								solo scatole complete   complete boxes only   à la boîte complète   nur kartonsweise	● PF017
1	-	17,60								solo scatole complete   complete boxes only   à la boîte complète   nur kartonsweise	● PF027
1	-	17,60								solo scatole complete   complete boxes only   à la boîte complète   nur kartonsweise	● PF027
2	-	35,20								solo scatole complete   complete boxes only   à la boîte complète   nur kartonsweise	● PF036
1	-	19,70								solo scatole complete   complete boxes only   à la boîte complète   nur kartonsweise	● PF020
1	-	19,70								solo scatole complete   complete boxes only   à la boîte complète   nur kartonsweise	● PF025
1	-	19,70								solo scatole complete   complete boxes only   à la boîte complète   nur kartonsweise	● PF025

pz / box	m² / box	kg / box	box / pallet	m² / pallet	kg / pallet	m² x pcs.	kg / m²	kg / crate	total kg	dimensione esterna cassa crate overall dimensions	codice prezzo price code
1	3,33	51,61	18	59,94	929,00	3,33	15,50	101	1030,00	291x134x31,5 cm	■ MF017
2	2,88	44,64	20	57,60	892,80	1,44	15,50	54	946,80	130,2x130,2x40 cm	■ MF012
2	1,44	27,99	36	51,84	895,68	-	-	-	-	-	■ MF004
1	1,00	44,00	24	24,00	1056,00	-	-	-	-	special pallet 103x103 cm	■ MF020
2	1,44	27,99	36	51,84	895,68	-	-	-	-	-	■ MF009
7	-	10,50								solo scatole complete   complete boxes only   à la boîte complète   nur kartonsweise	● PF004
8	-	9,28								solo scatole complete   complete boxes only   à la boîte complète   nur kartonsweise	● PF002
2	-	15,00								solo scatole complete   complete boxes only   à la boîte complète   nur kartonsweise	● PF030
2	-	15,00								solo scatole complete   complete boxes only   à la boîte complète   nur kartonsweise	● PF023
1	-	7,50								solo scatole complete   complete boxes only   à la boîte complète   nur kartonsweise	● PF032
1	-	7,50								solo scatole complete   complete boxes only   à la boîte complète   nur kartonsweise	● PF024







# codici prezzo e imballi

Price and packaging codes | Codes prix et emballages | Codes für Preis und Verpackungen

## upper

formato size	spessore thickness	superfici surfaces	colori colors			
			BUTTER	FOG	DOVE GREY	ELEPHANT GREY
 <b>40x100x2 gradone toro lineare</b> 15,75"x39,37"x0,78"	2 cm 2.OUT	Grip	-	UPP105	-	-
 <b>40x100x2 gradone toro angolare dx</b> 15,75"x39,37"x0,78"	2 cm 2.OUT	Grip	-	UPP106	-	-
 <b>40x100x2 gradone toro angolare sx</b> 15,75"x39,37"x0,78"	2 cm 2.OUT	Grip	-	UPP107	-	-
 <b>40x100x2 comp. gradone toro angolare interno</b> 15,75"x39,37"x0,78"	2 cm 2.OUT	Grip	-	UPP108	-	-
 <b>40x100x5 elemento L lineare</b> 15,75"x39,37"x1,97"	2 cm 2.OUT	Grip	-	UPP109	-	-
 <b>40x100x5 elemento L angolare dx</b> 15,75"x39,37"x1,97"	2 cm 2.OUT	Grip	-	UPP110	-	-
 <b>40x100x5 elemento L angolare sx</b> 15,75"x39,37"x1,97"	2 cm 2.OUT	Grip	-	UPP111	-	-

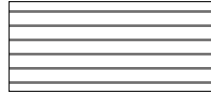
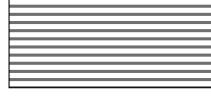
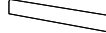
## woodblock

formato size	spessore thickness	superfici surfaces	colori colors		
			BRAVE OAK	BALANCE OAK	SCRATCH OAK
 <b>40x240 Rettificato</b> 15,75"x94,49"	6,5 mm	Real Matt 3D Texture	WOB003	WOB008	WOB017
 <b>24x240 Rettificato</b> 9,45"x94,49"	6,5 mm	Real Matt 3D Texture	WOB004	WOB009	WOB018
 <b>24x120 Rettificato</b> 9,45"x47,24"	6,5 mm	Real Matt 3D Texture	WOB005	WOB010	WOB019
 <b>120x278 decoro Stripy</b> 47,24"x109,45"	6,5 mm	Real Matt 3D Texture	WOB013	-	-
 <b>120x278 decoro Groove</b> 47,24"x109,45"	6,5 mm	Real Matt 3D Texture	-	WOB014	-
 <b>5x120 battiscopa</b> 1,97"x47,24"	6,5 mm	Real Matt 3D Texture	WOB020	WOB021	WOB022
 <b>33x120x5 gradino lineare LL</b> 12,99"x47,24"x1,97"	6,5 mm	Real Matt 3D Texture	WOB023	WOB024	WOB025
 <b>33x120x5 gradino angolare LL</b> 12,99"x47,24"x1,97"	6,5 mm	Real Matt 3D Texture	WOB026	WOB027	WOB028









pz / box	m² / box	kg / box	box / pallet	m² / pallet	kg / pallet	m² x pcs.	kg / m²	kg / crate	total kg	dimensione esterna cassa crate overall dimensions	codice prezzo price code
1	-	17,60	solo scatole complete   complete boxes only   à la boîte complète   nur kartonsweise								● PF017
1	-	17,60	solo scatole complete   complete boxes only   à la boîte complète   nur kartonsweise								● PF027
1	-	17,60	solo scatole complete   complete boxes only   à la boîte complète   nur kartonsweise								● PF027
2	-	35,20	solo scatole complete   complete boxes only   à la boîte complète   nur kartonsweise								● PF036
1	-	19,70	solo scatole complete   complete boxes only   à la boîte complète   nur kartonsweise								● PF020
1	-	19,70	solo scatole complete   complete boxes only   à la boîte complète   nur kartonsweise								● PF025
1	-	19,70	solo scatole complete   complete boxes only   à la boîte complète   nur kartonsweise								● PF025

pz / box	m² / box	kg / box	box / pallet	m² / pallet	kg / pallet	m² x pcs.	kg / m²	kg / crate	total kg	dimensione esterna cassa crate overall dimensions	codice prezzo price code
1	0,96	14,88	36	34,56	535,68	0,960	15,50	56	591,68	252x94x30,4 cm	■ MF015
1	0,58	8,99	54	31,10	485,00	0,576	15,50	56	541,00	252x94x30,4 cm	■ MF015
5	1,44	22,32	40	57,60	893,00	0,290	15,50	20	913,00	80x122x74 cm with lateral side	■ MF011
1	3,33	51,61	18	59,94	929,00	3,33	15,50	101	1030,00	291x134x31,5 cm	■ MF022
7	-	6,30	solo scatole complete   complete boxes only   à la boîte complète   nur kartonsweise								● PF004
2	-	15,00	solo scatole complete   complete boxes only   à la boîte complète   nur kartonsweise								● PF030
1	-	7,50	solo scatole complete   complete boxes only   à la boîte complète   nur kartonsweise								● PF032





# imballi lastre

Slab packaging | Emballages dalles | Verpackungen der Platten

IMBALLI PER LASTRE FORMATI 160x320 - 120x278 - 40x240 - 24x240   PACKAGING FOR SLABS SIZES 160x320 - 120x278 - 40x240 - 24x240   EMBALLAGES POUR DALLES FORMATS 160x320 - 120x278 - 40x240 - 24x240   VERPACKUNGEN FÜR FLIESENFORMATE 160x320 - 120x278 - 40x240 - 24x240							
Codice imballo Packaging code Code emballage Verpackungscode	Formato lastre Slab size Format dalles Fliesenformat	Descrizione imballo Packaging description Description emballage Beschreibung der Verpackung	Spessore Thickness Épaisseur Stärke	Contenuto imballo Packaging content Contenu emballage Verpackungsinhalt	Dimensione esterna cassa Crate overall dimensions Dimension extérieure de la caisse Außenabmessungen der Kiste	Peso imballo vuoto Weight of empty packaging Poids de l'emballage vide Leergewicht der Verpackung	
PAL249	160x320	Cassa 160x320 H. 40,4 Crate 160x320 H. 40,4 Caisse 160x320 H. 40,4 Kiste 160x320 H. 40,4	6,5 mm	Cassa da 1 a 14 Lastre Crate for 1 to 14 Slabs Caisse de 1 à 14 Dalles Kiste mit 1 bis 14 Fliesen	343,2x172,6x36,2 cm	136	
CAV006	160x320	Cavalletto 160x320 A-frame 160x320 Support 160x320 Ständer 160x320	6,5 mm	Cavalletto Max 42 Lastre Trestle Max 42 Slabs Support Max. 42 Dalles Ständer max. 42 Fliesen	330x75x196,8	166	
CAV001	160x320 120x278	Cavalletto in metallo 160x320 Metal A-frame 160x320 Support en métal 160x320 Metallbock 160x320	6,5 mm	Cavalletto Max 42 Lastre Trestle Max 42 Slabs Support Max. 42 Dalles Ständer max. 42 Fliesen  Cavalletto Max 44 Lastre Trestle Max 44 Slabs Support Max. 44 Dalles Ständer max. 44 Fliesen	330x75x198	150	
PAL267	120x278	Cassa 120x278 H. 39 Crate 120x278 H. 39 Caisse 120x278 H. 39 Kiste 120x278 H. 39	6,5 mm	Cassa da 10 a 18 Lastre Crate for 10 to 18 Slabs Caisse de 10 à 18 Dalles Kiste mit 10 bis 18 Fliesen	291x134x39	112	
PAL268	120x278	Cassa 120x278 H. 31,5 Crate 120x278 H. 31,5 Caisse 120x278 H. 31,5 Kiste 120x278 H. 31,5	6,5 mm	Cassa da 1 a 9 Lastre Crate for 1 to 9 Slabs Caisse de 1 à 9 Dalles Kiste mit 1 bis 9 Fliesen	291x134x31,5	101	
CAV009	120x278	Cavalletto 120x278 A-frame 120x278 Support 120x278 Ständer 120x278	6,5 mm	Cavalletto Max 44 Lastre Trestle Max 44 Slabs Support Max. 44 Dalles Ständer max. 44 Fliesen	288x75x156,6	137	
PAL247	40x240 24x240	Cassa Doghe H. 30,4 Crate Boards H. 30,4 Caisse Douves 30,4 Kiste Latten H. 30,4	6,5 mm	Cassa per Listelli Crate for Trims Caisse pour Listels Kiste für Leisten  Max 36 pz - 40x240 Max 54 pz - 24x240	252x94x30,4	56	
CAV011	160x320 120x278	Cavalletto in metallo 160x320 Metal A-frame 160x320 Support en métal 160x320 Metallbock 160x320	6,5 mm	Max 42 pz - 160x320  Max 44 pz - 120x278	388,6x75x185,7	123	

624 TECH INFO

IMBALLI PER LASTRE FORMATI 120x120   PACKAGING FOR SLABS SIZES 120x120   EMBALLAGES POUR DALLES FORMATS 120x120   VERPACKUNGEN FÜR FLIESENFORMATE 120x120							
Codice imballo Packaging code Code emballage Verpackungscode	Formato lastre Slab size Format dalles Fliesenformat	Descrizione imballo Packaging description Description emballage Beschreibung der Verpackung	Spessore Thickness Épaisseur Stärke	Contenuto imballo Packaging content Contenu emballage Verpackungsinhalt	Dimensione esterna cassa Crate overall dimensions Dimension extérieure de la caisse Außenabmessungen der Kiste	Peso imballo vuoto Weight of empty packaging Poids de l'emballage vide Leergewicht der Verpackung	
PAL253	120x120	Cassa 120x120 H. 56,2 Crate 120x120 H. 56,2 Caisse 120x120 H. 56,2 Kiste 120x120 H. 56,2	6,5 mm	Cassa da 8 a 20 scatole Crate for 8 to 20 boxes Caisse de 8 à 20 boîtes Kiste mit 8 bis 20 Kartons	130,2x130,2x40	37	
PAL265	120x120	Cassa 120x120 H. 25,5 Crate 120x120 H. 25,5 Caisse 120x120 H. 25,5 Kiste 120x120 H. 25,5	6,5 mm	Cassa da 1 a 7 scatole da 2 pz   Crate for 1 to 7 two piece boxes   Caisse de 1 à 7 boîtes de 2 pces   Kiste mit 1 bis 7 Kartons zu 2 Stck.	133x129x28	31	
CAV008	120x120	Cavalletto 120x120 A-frame 120x120 Support 120x120 Ständer 120x120	6,5 mm	Max 22 scatole da 2 pz Max 22 two piece boxes Max. 22 boîtes de 2 pces Max. 22 Kartons zu 2 Stck.	127x75x155	66	

625 TECH INFO

Le immagini sono solo indicative. Fondovalle si riserva di modificare gli imballi in qualsiasi momento. | The images are purely indicative. Fondovalle reserves the right to modify the packaging at any time. | Les images ne sont fournies qu'à titre indicatif. Fondovalle se réserve le droit de modifier les emballages à tout moment. | Die Abbildungen sind Richtwerte. Fondovalle behält sich vor, jederzeit die Verpackungen zu verändern.



# movimentazione casse

Box handling | Manutention des caisses | Versetzen der Kisten

Per una corretta movimentazione delle casse è necessario l'utilizzo di un carrello elevatore a forche, con una lunghezza di almeno 1,20 mt in caso di presa della cassa sul lato lungo. Per la presa sul lato corto la lunghezza delle forche deve essere di almeno 1,80 mt per la cassa 120x278 e di almeno 2,00 mt per la cassa 160x320. La distanza tra le forche non deve essere inferiore ai 60 cm. In condizioni normali, le forche vanno posizionate al centro del lato lungo del pallet, in quanto le stesse devono far presa su tutta la profondità del pallet.

Per maggiori dettagli consultare il sito [www.fondovalle.it](http://www.fondovalle.it)

For correct crate handling a forklift truck is required, with forks that are at least 1.20 m long if picking up the crates from the long side. If picking up from the short side, the forks must be at least 1.80 m long for the crates measuring 120x240 and at least 2.00 m long for the 160x320 crates. The forks must be at least 60 cm apart. In normal conditions, the forks must be positioned in the middle of the long side of the pallet so that they provide a stable hold all the way across the width of the pallet.

For more details, please visit our site at [www.fondovalle.it](http://www.fondovalle.it)

Pour une manutention correcte des caisses, il est nécessaire d'utiliser un chariot-élévateur à fourches d'une longueur d'au moins 1,20 m si l'on saisit la caisse du côté long. Pour la prise du côté court, la longueur minimale des fourches doit être de 1,80 m pour la caisse 120x278 et de 2,00 m pour la caisse 160x320. La distance entre les fourches ne doit pas être inférieure à 60 cm. Dans des conditions normales, positionner les fourches au centre du côté long de la palette car elles doivent faire prise sur toute la profondeur de cette dernière.

Pour tout renseignement complémentaire, consulter le site [www.fondovalle.it](http://www.fondovalle.it)

Für einen richtigen Transport der Kisten ist die Verwendung eines Gabelstaplers mit einer Gabellänge von mindestens 1,20 m beim Anheben der Kiste von der langen Seite notwendig. Zum Anheben der Kiste von der kurzen Seite müssen die Gabeln mindestens 1,80 m bei der Kiste zu 120x278 und mindestens 2,00 m bei der Kiste zu 160x320 lang sein. Der Abstand zwischen den Gabeln darf nicht weniger als 60 cm betragen. Unter normalen Bedingungen werden die Gabeln in der Mitte der Palette positioniert, da sie unter die gesamte Palettentiefe fahren müssen.

Für weitere Details siehe auf der Internetseite [www.fondovalle.it](http://www.fondovalle.it)

## movimentazione casse per lastre 160x320

Handling of boxes for 160x320 slabs | Manutention des caisses pour des dalles de 160x320 | Versetzen der Kisten bei 160x320-Platten

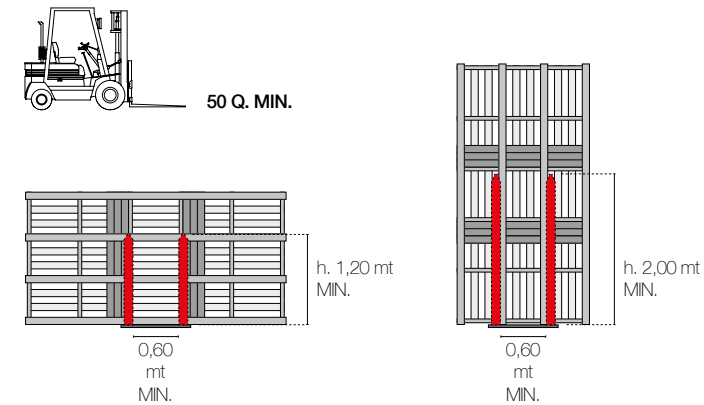

## movimentazione casse per lastre 120x278

Handling of boxes for 120x278 slabs | Manutention des caisses pour des dalles de 120x278 | Versetzen der Kisten bei 120x278-Platten

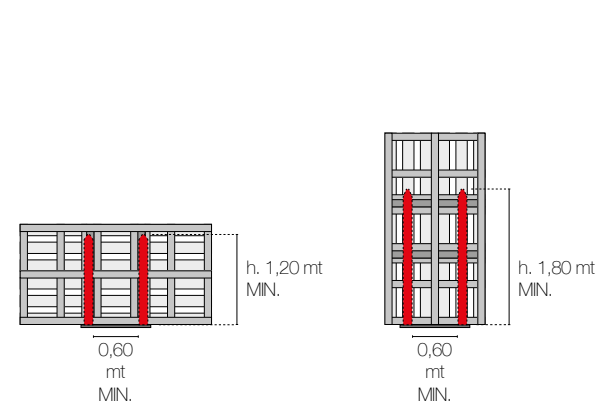

## movimentazione casse per lastre komi 40x240 | 24x240

Handling of boxes for KOMI slabs | Manutention des caisses pour des dalles de KOMI | Versetzen der Kisten bei KOMI-Platten

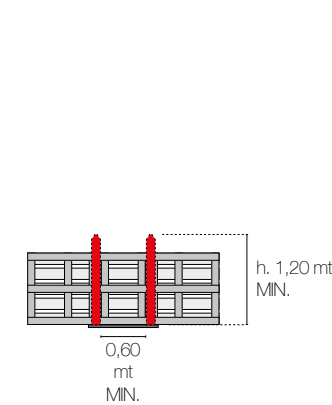

## movimentazione casse per lastre 120x120

Handling of boxes for 120x120 slabs | Manutention des caisses pour des dalles de 120x120 | Versetzen der Kisten bei 120x120-Platten

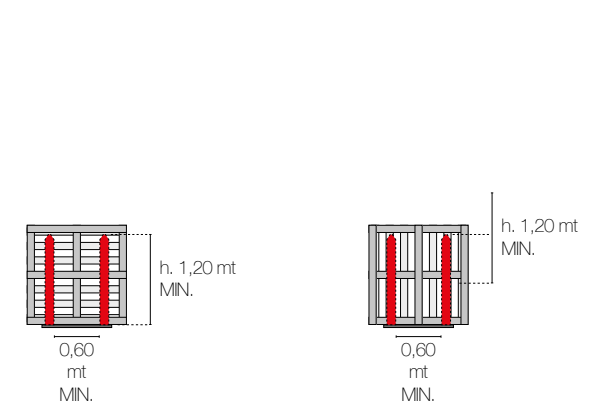

### Dimensione "esterna" cassa

"external" dimension of box | dimension "extérieure" de la caisse | außenabmessungen der Kiste

344,6x174,6x40,4 cm

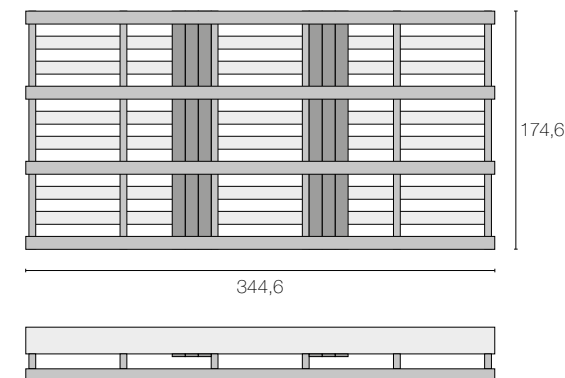

### Dimensione "esterna" cassa

"external" dimension of box | dimension "extérieure" de la caisse | außenabmessungen der Kiste

291x132x39

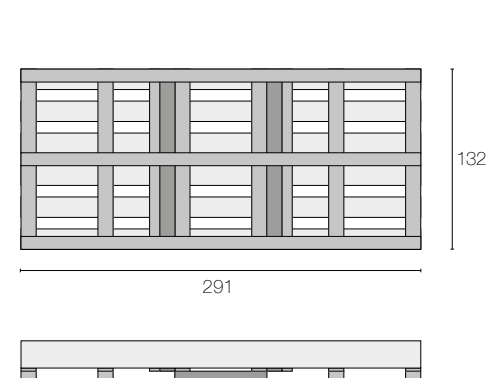

### Dimensione "esterna" cassa

"external" dimension of box | dimension "extérieure" de la caisse | außenabmessungen der Kiste

253x94x30,4

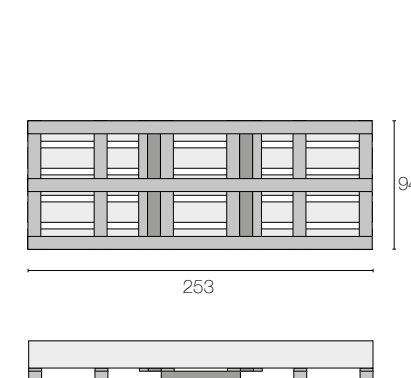

### Dimensione "esterna" cassa

"external" dimension of box | dimension "extérieure" de la caisse | außenabmessungen der Kiste

131,2x131,2x56,2

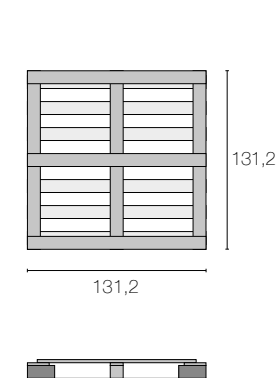



# consigli di pulizia

Cleaning tips | Conseils de nettoyage | Empfehlungen zum Säubern

**IT** Di seguito alcuni consigli per la pulizia e manutenzione dei materiali in grés porcellanato di Ceramica Fondovalle S.p.A.

I materiali di Ceramica Fondovalle S.p.A., non richiedono particolari condizioni per la loro cura e manutenzione. Grazie alla loro compattezza superficiale priva di porosità e alla loro resistenza ai prodotti chimici, essi si prestano ad essere utilizzati nei diversi contesti residenziali e commerciali per rivestire, interni ed esterni. Ceramica Fondovalle S.p.A. ricorda che la pulizia iniziale – pulizia della piastrellatura dopo la posa – rientra fra le attività da svolgere normalmente da parte del posatore come previsto dalla norma sulla posa (UNI EN 11493-2016).

La pulizia deve riguardare l'intera superficie della piastrellatura e quindi delle piastrelle, delle fughe, dei giunti di deformazione. Il processo di pulizia sarà considerato come correttamente effettuato se saranno soddisfatte le seguenti due condizioni: completa eliminazione di tutti i residui di materiale di posa, nessun danno (esito da attacco chimico o da abrasione meccanica) alla piastrellatura nella sua interezza ed ai singoli costituenti (fughe e giunti). I consigli che seguono hanno solo carattere indicativo e informativo. Ceramica Fondovalle S.p.A. fornisce materiali di eccellenza ceramica, duraturi nel tempo, resistenti e demanda le indicazioni per la loro pulizia, manutenzione e conseguente conservazione a FILA (anche per gli eventuali interventi straordinari), nell'ottica della scelta di un partner tecnico tutelante nella lunga fase di utilizzo del bene prodotto.

## 1. Pulizia iniziale

Prima della consegna dei locali al committente o della messa in servizio della pavimentazione è necessario eseguire la pulizia iniziale. Questa, ha lo scopo di eliminare lo sporco accumulato durante le attività di cantiere ed in particolare di rimuovere residui cementizi o epossidici di pittura e protettivi. Attenzione: la mancata o non adeguata esecuzione della pulizia iniziale genera un decadimento delle eccellenti caratteristiche di resistenza alla macchia peggiorando le prestazioni nel tempo e rendendo più complesse le attività di manutenzione ordinaria.

### 1.1. Rimozione di residui cementizi o di sigillante

Per questa tipologia di contaminanti la pulizia iniziale deve essere effettuata con detergenti adatti a rimuovere i residui cementizi. Sono pertanto da utilizzarsi detergenti con base acida\* (pH < 1), come DETERDEK PRO / INSTANT REMOVER della ditta Fila o equivalenti (SOLVACID – Geal; KERANET – Mapei; FLOOR CLEANER- Faber Chimica; ecc.). La pulizia dopo posa si esegue a completa stagionatura del sigillante seguendo le indicazioni fornite in scheda tecnica. Indicativamente il posatore seguirà questo procedimento schematizzato come segue:

- Spazzare bene il pavimento e aspirare; per il rivestimento, pulire bene la superficie con una spugna in cellulosa inumidita.
- Utilizzare un detergente diluito come previsto dal produttore
- Distribuire uniformemente la soluzione con il detergente, utilizzando:
  - Per ambienti residenziali: un normale spazzettone o monospazzola per i pavimenti, uno spruzzino per i rivestimenti.
  - Per grandi ambienti una monospazzola con tampone a ruvidità adeguata.
- Lasciare agire in funzione della quantità di materiale presente.
- Sciacquare il pavimento, passivare e raccogliere il residuo panneggiando oppure utilizzando un aspiraliquidi; Intervenire con un frattazzo in spugna umida per i rivestimenti.

Per maggiori informazioni sull'utilizzo dei detergenti leggere le istruzioni in etichetta e in scheda tecnica del produttore.

## COME USARLO?

### ISTRUZIONI INTERVENTO CON MACCHINA

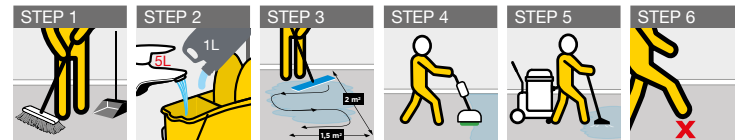

Spazzare bene il pavimento.

Utilizzare DETERDEK PRO diluito 1:5 (1 litro di DETERDEK PRO in 5 litri di acqua possibilmente calda).

Distribuire uniformemente la soluzione di DETERDEK PRO diluito frizionando pochi metri alla volta.

Lavare con monospazzola utilizzando il disco appropriato (bianco o verde).

Raccogliere il residuo con aspiraliquidi e risciacquare.

Non camminare sulla superficie fino a quando non è completamente asciutta.

Aspirare lo sporco / polvere.

Diluire CLEANER PRO 1:200, ovvero 25ml in 5L d'acqua.

Impostare la lavasciuga, quindi pulire la superficie.

Non camminare sulla superficie fino a quando non è completamente asciutta.

### ISTRUZIONI INTERVENTO MANUALE PAVIMENTI

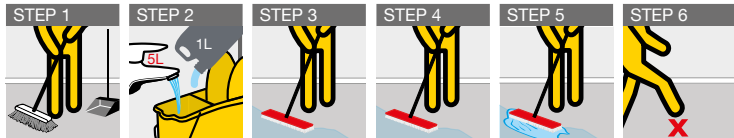

Spazzare bene il pavimento.

Utilizzare DETERDEK PRO diluito 1:5 (1 litro di DETERDEK PRO in 5 litri di acqua possibilmente calda).

Distribuire uniformemente la soluzione di DETERDEK PRO diluito frizionando pochi metri alla volta.

Intervenire con spazzolone.

Raccogliere il residuo con stracci e risciacquare.

Non camminare sulla superficie fino a quando non è completamente asciutta.

### ISTRUZIONI INTERVENTO MANUALE RIVESTIMENTI



Una volta stuccato, attendere che l'impasto si addensi e diventi opaco (in genere dai 10 ai 30 minuti) in accordo con i tempi forniti dal produttore.

Procedere ad una prima pulizia della superficie con spugna in cellulosa inumidita e strizzata.

Procedere con l'operazione di finitura a fresco: spruzzare INSTANT REMOVER in modo omogeneo sulla superficie e lasciare agire 1-2 minuti a seconda della finitura del materiale.

Intervenire con un frattazzo in spugna umida, avendo cura di risciacquarlo frequentemente per mantenerlo pulito.

In caso di residui tenaci ripassare dopo 1 ora dalla stuccatura seguendo le istruzioni appena descritte. Per la messa in esercizio, riferirsi alle istruzioni del produttore dello stucco.

Attenzione: nel caso di residui più tenaci, ripetere l'applicazione seguendo le stesse modalità e lasciando agire più a lungo il prodotto. Non usare su marmi lucidi e su tutti i materiali sensibili agli acidi. Accertarsi con un test preliminare su una piccola porzione di superficie, dell'effettiva resistenza del materiale al prodotto. Per gli elementi in alluminio, impiegare il prodotto secondo le indicazioni d'uso e con spugna morbida.

### 1.2. Rimozione di residui a base epossidica

Per questi materiali, il posatore è tenuto a seguire le istruzioni e raccomandazioni fornite dal produttore e le specifiche tecniche e progettuali indicate dalla norma sulla posa (UNI EN 11493-2016). Si suggerisce di effettuare la pulizia iniziale con detergenti professionali specifici come: CR10 della ditta Fila (o equivalenti: EPOSOLV della ditta Geal); o altri specifici suggeriti dal produttore stesso del sigillante.

## 2. Pulizia di fine cantiere

Al termine dei lavori di cantiere, eseguita la pulizia iniziale, è necessaria una accurata rimozione di tutti gli altri agenti contaminanti e sporcanti che derivano dalle altre lavorazioni di cantiere (elettricisti, imbianchini, tinteggiatori etc.). Si raccomanda sempre di aver cura di proteggere il pavimento o il rivestimento per evitare danni meccanici dovuti all'inevitabile presenza di materiali duri o abrasivi.

## 3. Manutenzione ordinaria della piastrellatura

Per la pulizia di tutti i giorni Ceramica Fondovalle S.p.A. consiglia l'utilizzo di detergenti specifici per la ceramica con basso residuo, attenendosi ai consigli del produttore. Si ricorda che il problema della formazione di patine e aloni su tutti i tipi di superfici è dovuto alla mancanza di rimozione dello sporco ordinario, lo sporco va sempre rimosso, non spalmato.

## COME USARLO?

### ISTRUZIONI INTERVENTO CON MACCHINA

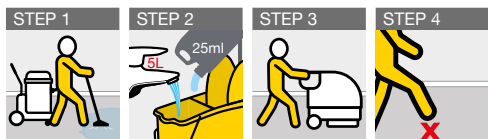

Aspirare lo sporco / polvere.

Diluire CLEANER PRO 1:200, ovvero 25ml in 5L d'acqua.

Impostare la lavasciuga, quindi pulire la superficie.

Non camminare sulla superficie fino a quando non è completamente asciutta.



### ISTRUZIONI INTERVENTO MANUALE PAVIMENTI

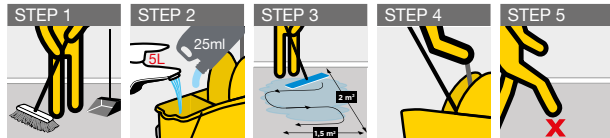

Spazzare bene il pavimento.

Diluire CLEANER PRO 1:200, ovvero 25ml in 5L d'acqua.

Pulire 2-3 m² per volta usando un mop con il metodo S movement.

Risciacquare e strizzare il mop prima di lavare una nuova area. Se il pavimento è molto sporco, lavarlo per due volte.

Non camminare sulla superficie fino a quando non è completamente asciutta.

### ISTRUZIONI INTERVENTO MANUALE RIVESTIMENTI, TOP BAGNO / CUCINA, TAVOLI



Spruzzare il prodotto CLEAN & SHINE sulla superficie tenendo il flacone in posizione verticale a circa 20/30 cm dal punto di applicazione.

Passare l'area con panno morbido.

Attenzione: nel caso di residui più tenaci, ripetere l'applicazione seguendo le stesse modalità e lasciando agire più a lungo il prodotto. Non usare su marmi lucidi e su tutti i materiali sensibili agli acidi. Accertarsi con un test preliminare su una piccola porzione di superficie, dell'effettiva resistenza del materiale al prodotto. Per gli elementi in alluminio, impiegare il prodotto secondo le indicazioni d'uso e con spugna morbida.

Per facilitare l'esecuzione indichiamo di seguito i tipi di strumenti adatti alle diverse tipologie di superfici ceramiche:

- per superfici LISCE (normali, satinata, lucide o levigate): PANNO UMIDO e/o SCOTCH-BRITE ANTIGRAFFIO UMIDO (colori BIANCO – meglio - o AZZURRO);

- per superfici STRUTTURATE: SPUGNA NON ABRASIVA UMIDA e/o SPAZZOLA A SETOLE FINI IN SAGGINA O PLASTICA;

Il PANNO e la SPUGNA sono più indicati per sporchi più fini, più liquidi, lo SCOTCH-BRITE ANTIGRAFFIO e la SPAZZOLA per sporchi più grossolani, più materici.

Tutti i suddetti strumenti non arrecano danni ai materiali ceramici ma sono meno efficaci se non utilizzati come indicato, anche se può capitare che funzionino ugualmente.

I panni possono essere anche in microfibra che in alcuni casi può aiutare per la sua diversa azione meccanica, sempre in abbinamento alla preventiva azione chimica. Con principio simile inoltre segnaliamo anche la possibilità di utilizzo delle spugne melaminiche (o "magiche") tenendo particolare attenzione ai materiali satinati opachi o lucidi in quanto, essendo leggermente abrasive, possono cambiare l'aspetto originale.

## 4. Manutenzione straordinaria della piastrellatura

Talvolta può manifestarsi la necessità di pulire macchie generate da eventi accidentali che occorrono nel lungo periodo di vita della piastrellatura.

Nella gran parte dei casi, utilizzando il giusto prodotto di pulizia e manutenzione, il problema si risolve senza danni e con facilità.

Ceramica Fondovalle S.p.A. fornisce assistenza tecnica di pulizia su tutta la gamma dei suoi prodotti attraverso il centro di assistenza FILA specializzato. Abbiamo a cuore la soddisfazione dei nostri clienti per questo ci affidiamo a partners specializzati con diffusione capillare.

Per accedere al servizio chiamare il numero di assistenza FILA dedicato +39 049 946 73 00 specificando Fondovalle oppure visitare il sito [www.filasolutions.com](http://www.filasolutions.com)

**EN** Here are some tips for cleaning and maintaining the porcelain stoneware materials of Ceramica Fondovalle S.p.A.

Ceramica Fondovalle S.p.A. materials do not require special care and maintenance. Thanks to their surface compactness free from porosity and their resistance to chemicals, they lend themselves to being used in different residential and commercial contexts as cladding, both indoors and outdoors.

Ceramica Fondovalle S.p.A. reminds you that the initial cleaning of the tiling after installation is one of the activities that should normally be performed by the installer as required by the installation standard (UNI EN 11493-2016).

Cleaning must cover the entire surface of the tiling and therefore of the tiles, joints and expansion joints. The cleaning process will be considered correctly performed if the following two conditions are met: complete removal of all the residues of laying material, no damage (result of chemical attack or mechanical abrasion) to the tiling in its entirety and to the individual constituents (grouts and joints). The following tips are only indicative and informative. Ceramica Fondovalle S.p.a. supplies long-lasting, resistant ceramic materials of excellence. For instructions for their cleaning, maintenance and care, please refer to FILA (also for any special treatments), which will provide you with all the technical products and information needed for the future file of the product.

## 1. Initial cleaning

Before the handover of the premises to the client or commissioning of the flooring, it is necessary to perform initial cleaning. This is aimed at removing any dirt that has accumulated during the site activities and in particular to remove cementitious or epoxy paint and protective residues. Attention: non- or inadequate initial cleaning can result in deterioration of the excellent stain resistance characteristics, worsening performance over time and making the activities of ordinary maintenance more complex.

### 1.1. Removal of cement or sealant residues

For these types of contaminants the initial cleaning must be performed with detergents suitable for removing cement residues. As such, acid-based detergents\* (pH <1), such as DETERDEK PRO by the company Fila, or equivalent substances (SOLVACID – Geal; KERANET – Mapei; FLOOR CLEANER- Faber Chimica, etc.) should be used. Cleaning after laying is to be performed when the sealant has completely hardened following the instructions provided in the technical data sheet. Indicatively, the installer should follow the procedure outlined as follows:

- Sweep the floor well and then vacuum it; for wall tiles, clean the surface well with a damp cellulose sponge.
- Use a diluted acid cleaner as recommended by the manufacturer;
- Distribute the solution evenly with the detergent diluted, using:
  - For residential spaces: for floors, a normal long-handled cleaning brush or a single-disc cleaner, for wall tiles, a spray.
  - For large environments, a single-disc machine with pad of suitable roughness.
- Leave to act according to the quantity of material present.
- Rinse the floor, passivate, and wipe up or vacuum the remaining liquid; use a damp sponge trowel for wall tiles.

For further information on the use of detergents, read the instructions on the label and in the manufacturer's data sheet.

## HOW IS IT USED?

### MACHINE CLEANING INSTRUCTIONS



Sweep the floor thoroughly.

Use DETERDEK PRO diluted 1:5 (1 litre of DETERDEK PRO in 5 litres of water - hot if possible).

Apply the diluted DETERDEK PRO solution evenly, rubbing a few metres at a time.

Wash with a single-disc scrubbing machine, using the appropriate disc (white or green).

Collect residues with a liquid vacuum cleaner and rinse.

Do not walk on the surface until completely dry.



# consigli di pulizia

Cleaning tips | Conseils de nettoyage | Empfehlungen zum Säubern



## INSTRUCTIONS FOR FINISHING FLOOR TILES MANUALLY

STEP 1	STEP 2	STEP 3	STEP 4	STEP 5	STEP 6
Sweep the floor thoroughly.	Use DETERDEK PRO diluted 1:5 (1 litre of DETERDEK PRO in 5 litres of water - hot if possible).	Apply the diluted DETERDEK PRO solution evenly, rubbing a few metres at a time.	Scrub with a long-handled brush.	Soak up residues with rags and rinse.	Do not walk on the surface until completely dry.

## INSTRUCTIONS FOR FINISHING WALL TILES MANUALLY

STEP 1	STEP 2	STEP 3	STEP 4	STEP 5
Once grouted, wait for the grout to thicken and turn matt (in general, from 10 to 30 minutes), as per the time stated by the manufacturer.	Clean the tiling a first time using a slightly damp cellulose sponge.	Carry out the wet-finishing procedure; i.e. spray the INSTANT REMOVER evenly over the surface and leave it to work for 1 to 2 minutes, depending on the finish of the material.	Wipe with a damp sponge trowel, rinsing the trowel frequently to keep it clean.	For stubborn residues, wipe the surface again an hour after grouting following the instructions set out above. For use of the tiled area, see the instructions given by the grout manufacturer.

Important: for more stubborn dirt, repeat the application with the same procedure, leaving the product to act for longer. Do not use on polished marbles or any materials vulnerable to attack by acids. Perform a preliminary test on a small portion of the surface to check that the material is resistant to the product.

## 1.2. Removal of epoxy-based residues

For these materials, the installer is required to follow the instructions and recommendations supplied by the manufacturer and the technical and design specifications indicated by the standard on installation (UNI EN 11493-2016). It is advisable to perform the **initial cleaning** with specific **professional detergents such as: CR10** by the company Filas (or equivalent: EPOSOLV by the company Geal) or referring to other specifications suggested by the sealant manufacturer.

## 2. Cleaning at the end of the site work

At the end of the site works, after the **initial cleaning**, careful removal of all other contaminants and of any dirt generated from other work on site (electricians, painters, painters etc.) is required. We recommend that you place protective sheeting over the floor or wall to prevent mechanical damage which could be caused by the presence of hard or abrasive substances.

## 3. Ordinary maintenance of the tiling

For everyday cleaning, Ceramica Fondovalle S.p.A. recommends the use of specific detergents for low-residue ceramics, following the manufacturer's recommendations. Remember that the problem of the formation of films and smears on **all types of surfaces** is due to not having removed ordinary dirt. Dirt must always be removed and not spread around.

## HOW IS IT USED?

### MACHINE CLEANING INSTRUCTIONS

STEP 1	STEP 2	STEP 3	STEP 4
Remove dirt / dust.	Dilute CLEANER PRO 1:200, meaning 25 ml in 5 L of water.	Set the floor cleaning machine then clean the surface.	Do not walk on the surface until completely dry.

## INSTRUCTIONS FOR FINISHING FLOOR TILES MANUALLY

STEP 1	STEP 2	STEP 3	STEP 4	STEP 5
Sweep the floor thoroughly.	Dilute CLEANER PRO 1:200, meaning 25 ml in 5 L of water.	Clean 2-3 m2 at a time with a mop, using a figure-of-eight motion.	Rinse and squeeze the mop before washing a new area. If the floor is very dirty, wash it twice.	Do not walk on the surface until completely dry.

## INSTRUCTIONS FOR FINISHING WALL TILES, KITCHEN OR BATHROOM COUNTERTOPS, AND TABLES MANUALLY

STEP 1	STEP 2
Spray the surface with CLEAN & SHINE, holding the bottle upright and approximately 20/30 cm from the application area.	Wipe the area with a soft cloth.

Important: for more stubborn dirt, repeat the application with the same procedure, leaving the product to act for longer. Do not use on polished marbles or any materials vulnerable to attack by acids. Perform a preliminary test on a small portion of the surface to check that the material is resistant to the product.

To facilitate this action, we indicate below the types of tools suitable for the different types of ceramic surfaces:

- for SMOOTH surfaces (normal, satin, glossy or sanded), WET CLOTH and/or WET ANTI-SCRATCH SCOTCH-BRITE (WHITE colours - preferably LIGHT BLUE);
- for STRUCTURED surfaces, WET NON-ABRASIVE SPONGE and/or FINE BRISTLE BRUSH IN SORGHUM OR PLASTIC;

The CLOTH and the SPONGE are more suited for finer, more liquid types of dirt, the SCOTCH-BRITE ANTI-SCRATCH and the BRUSH for coarser, more material dirt.

None of the above tools cause damage to ceramic materials but are less effective if not used as indicated, even if they may still work. The cloths can also be microfibre which in some cases are especially advantageous due to the different mechanical action of this material, always in combination with the preventive chemical action. With this in mind, we also point out the possibility of using melamine (or "magic") sponges, paying particular attention to matt or glossy satin materials as, being slightly abrasive, they can alter the original appearance.

## 4. Extraordinary maintenance of the tiling

Sometimes it may be necessary to clean stains generated by accidental events that occur in the long life of the tiling. In most cases, using the right cleaning and maintenance product, the problem is resolved without damage and with ease.

Ceramica Fondovalle S.p.A. provides technical assistance for the cleaning of its entire product range through the FILA specialised service centre. Our customers' satisfaction matters to us, so we work with specialist partners who provide full geographical cover.

To request this service, call the dedicated service number provided by FILA (+39 049 946 73 00), specifying Fondovalle, or visit the website: [www.filasolutions.com](http://www.filasolutions.com)

FR\_Voici quelques conseils pour le nettoyage et l'entretien du matériel en grès cérame de Ceramica Fondovalle S.p.A.

Le matériel de Ceramica Fondovalle S.p.A. ne nécessitent pas de conditions particulières pour leur entretien et leur maintenance. Grâce à la compacité de leur surface sans porosité et à leur résistance aux produits chimiques, ils peuvent être utilisés dans divers contextes résidentiels et commerciaux pour revêtir les espaces intérieurs et extérieurs. Ceramica Fondovalle S.p.A. rappelle que le nettoyage initial - c'est-à-dire le nettoyage du carrelage après la pose - est une activité généralement confiée par le carreleur comme le prévoit la norme sur la pose (UNI EN 11493-2016).

Le nettoyage doit couvrir toute la surface du carrelage et donc les carreaux, les joints et les raccords de déformation. Le nettoyage est réputé correctement effectué si les deux conditions suivantes sont remplies : élimination complète de tous les résidus du matériel de pose, absence de dommages (résultant d'une attaque chimique ou d'une abrasion mécanique) sur l'ensemble du carrelage et sur les différents éléments (joints et raccords). Les conseils suivants sont exclusivement fournis à titre indicatif et informatif. Ceramica Fondovalle S.p.A. fournit un matériel d'excellence en céramique, durable et résistant et délègue à FILA le soin de fournir des indications pour leur nettoyage, leur entretien et leur conservation conséquente (également pour toute intervention extraordinaire), un partenaire technique qui fournit son expérience tout au long de la vie du produit.

## 1. Nettoyage initial

Un nettoyage initial doit être effectué avant la remise des locaux au client ou la mise en service du revêtement de sol. L'objectif est d'éliminer la saleté accumulée pendant les activités de construction et en particulier les résidus de ciment ou à base époxy de la peinture et des agents de protection. Attention : si l'on effectue mal ou si l'on omet d'effectuer le nettoyage initial, les excellentes caractéristiques de résistance aux taches se détériorent, entraînant une dégradation des performances dans le temps ce qui complique l'entretien de routine.

### 1.1. Élimination des résidus de ciment ou de scellant

Pour ce type de contaminants, le nettoyage initial doit être effectué avec des détergents adaptés à l'élimination des résidus de ciment. Par conséquent, il faut utiliser des détergents à base acide (pH < 1), tels que DETERDEK PRO de la société Filas ou des produits équivalents (SOLVACID - Geal ; KERANET - Mapei, FLOOR CLEANER - Faber Chimica, etc.). Le nettoyage après la pose est effectué lorsque le scellant a complètement durci, en suivant les instructions fournies sur la fiche technique. À titre indicatif, l'installateur suivra cette procédure schématique comme suit :

- Bien balayer le sol et passer l'aspirateur ; pour le revêtement mural, bien nettoyer la surface avec une éponge en cellulose humidifiée.
- Utiliser un détergent acide dilué comme le prescrit le fabricant ;
- Répartir uniformément la solution avec le détergent dilué, en utilisant :
  - Pour les environnements résidentiels : une brosse ordinaire ou une monobrosse pour les sols, un vaporisateur pour les revêtements muraux.
  - Pour les grandes surfaces, utiliser un nettoyeur monobrosse avec un tampon d'une rugosité appropriée ;
- Laisser agir en fonction de la quantité de matériel présent ;
- Rincer le sol, passiver et ramasser les résidus en drapant ou en essuyant ou en utilisant un aspirateur à eau ; intervenir avec une taloche en éponge humide pour les revêtements muraux.

Pour plus d'informations sur l'utilisation des détergents, lire les instructions figurant sur l'étiquette et sur la fiche technique du fabricant.

## COMMENT L'UTILISER ?

### INSTRUCTIONS INTERVENTION AVEC MACHINE

ÉTAPE 1	ÉTAPE 2	ÉTAPE 3	ÉTAPE 4	ÉTAPE 5	ÉTAPE 6
Bien balayer le sol.	Utiliser DETERDEK PRO dilué 1:5 (1 litre de DETERDEK PRO dans 5 litres d'eau, chaude de préférence).	Répartir uniformément la solution de DETERDEK PRO dilué en frottant énergiquement peu de mètres à la fois.	Laver avec une monobrosse en utilisant le bon disque (blanc ou vert).	Ramasser les résidus à l'aide d'un aspirateur à liquides, puis rincer.	Attendre que la surface soit bien sèche avant de marcher dessus.

### INSTRUCTIONS INTERVENTION MANUELLE SOLS

ÉTAPE 1	ÉTAPE 2	ÉTAPE 3	ÉTAPE 4	ÉTAPE 5	ÉTAPE 6
Bien balayer le sol.	Utiliser DETERDEK PRO dilué 1:5 (1 litre de DETERDEK PRO dans 5 litres d'eau, chaude de préférence).	Répartir uniformément la solution de DETERDEK PRO dilué en frottant énergiquement peu de mètres à la fois.	Utiliser un balai-brosse.	Ramasser les résidus à l'aide de serpillières, puis rincer.	Attendre que la surface soit bien sèche avant de marcher dessus.

### INSTRUCTIONS INTERVENTION MANUELLE REVÊTEMENTS MURAUX

ÉTAPE 1	ÉTAPE 2	ÉTAPE 3	ÉTAPE 4	ÉTAPE 5
Une fois le jointoiment effectué, attendre que le mélange épaississe et devienne opaque (généralement 10 à 30 minutes), conformément aux temps fournis par le fabricant.	Procéder à un premier nettoyage de la surface avec une éponge en cellulose humidifiée et essorée.	Procéder à l'opération de finition immédiatement après la pose : pulvériser uniformément INSTANT REMOVER sur la surface et laisser agir pendant 1-2 minutes en fonction de la finition du matériau.	Intervenir avec une taloche en éponge humide, en veillant à la rincer fréquemment afin de préserver sa propreté.	En présence de résidus tenaces, passer à nouveau 1 heure après le jointoiment, en suivant les instructions qui viennent d'être décrites. Pour la mise en service, se référer aux instructions du fabricant du mastic.

Attention : en cas de résidus plus tenaces, répéter l'application de la même façon en laissant agir le produit plus longtemps. Ne pas utiliser sur marbres polis ni sur les matériaux sensibles aux acides. Sur une petite portion de surface, faire un test préliminaire pour s'assurer de l'effective résistance du matériau au produit.

### 1.2. Élimination des résidus à base époxy

Pour ce type de matières, l'installateur doit suivre les instructions et les recommandations fournies par le fabricant ainsi que les spécifications techniques et de conception indiquées par la norme sur la pose (UNI EN 11493-2016). On suggère d'effectuer le **nettoyage initial** avec des détergents **professionnels spécifiques** tels que : CR10 de la société Filas (ou un produit équivalent : EPOSOLV de la société Geal) ; ou d'autres produits spécifiques suggérés par le fabricant du scellant.

### 2. Nettoyage de fin de chantier

À la fin du chantier, après le nettoyage initial, il est nécessaire d'éliminer soigneusement tous les autres agents contaminants et salissants résultant d'autres travaux sur le chantier (électriciens, peintres, etc.). On recommande de toujours veiller à protéger le sol ou le revêtement mural afin d'éviter tout dommage mécanique dû à la présence inévitable de matériaux durs ou abrasifs.

### 3. Entretien courant du carrelage

Pour le nettoyage quotidien, Ceramica Fondovalle S.p.A. recommande l'utilisation de détergents spécifiques pour la céramique à faible résidu, en s'en tenant au conseil du fabricant. On rappelle que le problème de la patine et des halos qui se forment sur tous les types de surfaces est dû au défaut d'élimination de la saleté ordinaire ; il faut toujours éliminer la saleté sans l'étaler.

## COMMENT L'UTILISER ?

### INSTRUCTIONS INTERVENTION AVEC MACHINE

ÉTAPE 1	ÉTAPE 2	ÉTAPE 3	ÉTAPE 4
Aspirer les saletés / poussières.	Diluer CLEANER PRO 1:200, soit 25 ml dans 5 L d'eau.	Configurer l'autolaveuse, puis laver la surface.	Attendre que la surface soit bien sèche avant de marcher dessus.



# consigli di pulizia

Cleaning tips | Conseils de nettoyage | Empfehlungen zum Säubern



## INSTRUCTIONS INTERVENTION MANUELLE SOLS

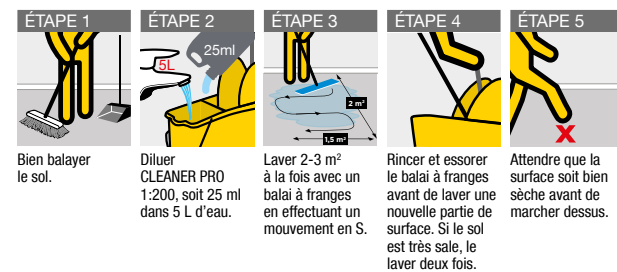

## INSTRUCTIONS D'INTERVENTION MANUELLE REVÊTEMENTS, DESSUS DE SALLE DE BAIN / CUISINE, TABLES



Vaporiser le produit CLEAN & SHINE sur la surface en gardant le flacon en position verticale à environ 20/30 cm du point d'application.

Essuyer la zone avec un chiffon doux.

Attention : en cas de résidus plus tenaces, répéter l'application de la même façon en laissant agir le produit plus longtemps. Ne pas utiliser sur marbres polis ni sur les matériaux sensibles aux acides. Sur une petite portion de surface, faire un test préliminaire pour s'assurer de l'effective résistance du matériau au produit.

Afin de faciliter l'exécution, nous indiquons ci-dessous les types d'instruments adaptés aux différents types de surfaces céramiques :

- pour les surfaces LISSES (normales, satinées, brillantes ou polies), CHIFFON HUMIDE et/ou SCOTCH-BRITE ANTI-RAYURES HUMIDE (couleurs BLANC - mieuX - ou BLEU) ;
- pour les surfaces STRUCTURÉES, ÉPONGE NON ABRASIVE HUMIDE et/ou BROSSE À SOIES FINES EN GENÊT OU EN PLASTIQUE ;

Le CHIFFON et l'ÉPONGE conviennent aux saletés plus fines et plus liquides, le SCOTCH BRITE ANTI-RAYURES et la BROSSE à la saleté plus grossière et plus texturée.

Tous les outils susmentionnés n'endommagent pas les matières céramiques mais ils perdent de leur efficacité (ce qui ne les empêche pas de fonctionner dans certains cas) si l'on ne suit pas les instructions fournies. Les chiffons peuvent également être en microfibre qui représente une action mécanique très utile, toujours en combinaison avec l'action chimique préventive. Dans le même ordre d'idées, nous aimerions également souligner la possibilité d'utiliser des éponges en mélamine (ou éponges « magiques ») ; mais il faut faire très attention aux carrelages satinés, opaques ou brillants, car ces éponges légèrement abrasives peuvent modifier leur aspect original.

## 4. Entretien exceptionnel du carrelage

Parfois, il peut être nécessaire de nettoyer des taches causées à l'occasion d'événements accidentels survenant pendant la longue vie du carrelage. Dans la plupart des cas, l'utilisation du bon produit de nettoyage et d'entretien résoudra le problème sans dommages et avec facilité.

Ceramica Fondovalle S.p.A. fournit une assistance technique de nettoyage sur toute sa gamme de produits par l'intermédiaire du spécialiste après-vente FILA. Nous attachons une grande importance à la satisfaction de nos clients, et à cet effet nous collaborons avec des partenaires spécialisés sur tout le territoire national.

Pour accéder au service, appeler le numéro d'assistance FILA dédié +39 049 946 73 00 en spécifiant Fondovalle ou visiter le site suivant [www.filasolutions.com](http://www.filasolutions.com)

DE\_Hier einige Empfehlungen zur Reinigung und Pflege der Materialien aus Feinsteinzeug der Ceramica Fondovalle S.p.A.

Die Materialien der Ceramica Fondovalle S.p.A. erfordern keine besonderen Bedingungen für ihre Pflege und Wartung. Aufgrund ihrer kompakten Oberfläche ohne poröse Stellen und ihrer Beständigkeit gegenüber Chemikalien eignen sie sich für den Einsatz in verschiedenen Wohn- und Gewerbebereichen als Beläge im Innen- und Außenbereich. Die Ceramica Fondovalle S.p.A. erinnert Sie daran, dass die Erstreinigung - das Reinigen der Fliesen nach der Verlegung - eine der Tätigkeiten ist, die gemäß der Verlegenorm (UNI EN 11493-2016) normalerweise der Fliesenleger ausführen muss.

Die Reinigung muss die gesamte Oberfläche der Fliesen umfassen und somit die Fliesen, Fugen und Dehnfugen. Der Reinigungsvorgang gilt als korrekt durchgeführt, wenn die folgenden beiden Bedingungen erfüllt sind: vollständige Beseitigung aller Rückstände des Verlegematerials, keine Beschädigung (durch chemischen Angriff oder mechanischen Abrieb) der gesamten Fliesen und der einzelnen Bestandteile (Fugen und Dehnfugen). Die folgenden Empfehlungen sind nur Richtwerte und dienen zur Information. Die Ceramica Fondovalle S.p.A. liefert Materialien aus ausgezeichneter Keramik, die langlebig und widerstandsfähig sind, und empfiehlt die Firma FILA als technischen Partner für die Reinigung, die Pflege der Produkte und eventuelle Sondereingriffe.

### 1. Erstreinigung

Vor der Übergabe der Räume an den Auftraggeber bzw. der Benutzung des Bodenbelags ist es notwendig, die Erstreinigung durchzuführen. Diese hat den Zweck, den Schmutz zu beseitigen, der sich während der Arbeiten auf der Baustelle angesammelt hat. Insbesondere handelt es sich dabei um die Beseitigung von Mörtel- oder Epoxidrückstände aus Anstrichen und Schutzmitteln. Achtung: die mangelnde oder unzureichende Durchführung der Erstreinigung führt zu einer Verschlechterung der ausgezeichneten Eigenschaften der Fleckenbeständigkeit, wodurch sich die Leistungen im Laufe der Zeit verschlechtern und die gewöhnlichen Wartungsarbeiten komplexer werden.

#### 1.1. Entfernung von Rückständen von Mörtel und Dichtmittel

Bei dieser Art von Verunreinigungen muss die **Erstreinigung** mit Reinigungsmitteln durchgeführt werden, die zur Entfernung von Mörtelresten geeignet sind. Daher müssen Reinigungsmittel auf „Säurebasis“ verwendet werden (pH <1), wie z. B. DETERDEK PRO der Firma FILA oder ein gleichwertiges Produkt (SOLVACID - Geal; KERANET - Mapei; FLOOR CLEANER - Faber Chimica usw.). Die Reinigung nach der Installation erfolgt nach vollständiger Aushärtung des Dichtmittels gemäß den Anweisungen im technischen Datenblatt. Der Fliesenleger geht dazu wie nachfolgend aufgeführt vor:

- Den Boden gründlich fegen und absaugen; Für die Verlegung auf der Wand die Oberfläche mit einem angefeuchteten Zelloleschwamm gut reinigen.
- Verwendung eines vom Hersteller empfohlenen verdünnten Reinigers
- Gleichmäßiges Verteilen der Lösung mit dem Reinigungsmittel unter Einsatz von:
  - Für Wohnräume: ein normaler Besen oder eine Reinigungsmaschine für Böden, ein Sprühergerät für die Wandbeläge.
  - Bei großen Räumen eine Reinigungsmaschine mit ausreichend rauem Pad;
- Je nach vorhandener Materialmenge einwirken lassen;
- Reinigen Sie den passivierten Boden mit Wasser und nehmen Sie die Rückstände durch Abwischen oder mit einem Flüssigstaubsauger auf. Verwenden Sie für die Wandbeläge ein feuchtes Reibebrett mit Schwamm.

Weitere Informationen zur Verwendung der Reinigungsmittel finden Sie in den Anweisungen auf dem Etikett und im technischen Datenblatt des Herstellers.

## ANWENDUNG

### ANWEISUNGEN ZUR REINIGUNG MIT MASCHINE



Den Boden gut sauberkehren.

DETERDEK PRO 1:5 verdünnt verwenden (1 Liter DETERDEK PRO auf 5 Liter möglichst warmen Wassers).

Die Lösung aus DETERDEK PRO und Wasser gleichmäßig verteilen und den Boden jeweils nur wenige Meter schrittweise scheuern.

Mit der passenden Scheibe (weiß oder grün) an der Einbürsten-Maschine die Reinigung durchführen.

Die Rückstände mit einem Flüssigkeitssauger aufnehmen und nachspülen.

Die Oberfläche nicht betreten, solange sie nicht vollständig getrocknet ist.

## HINWEISE ZUM MANUELLEN VORGEHEN AUF BODENBELÄGEN

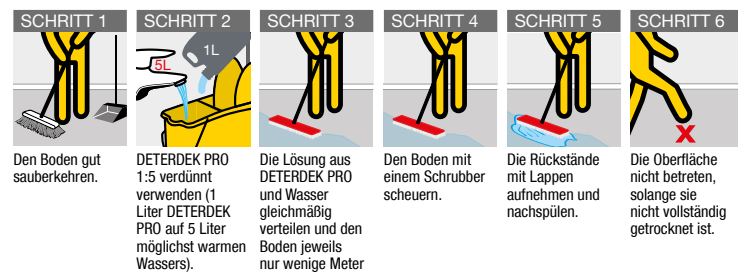

## HINWEISE ZUM MANUELLEN VORGEHEN AUF BODENBELÄGEN



Nach dem Verfugen warten, bis der Mörtel entsprechend den Angaben des Herstellers dicker und undurchsichtiger geworden ist (im Allgemeinen 10 bis 30 Minuten).

Die Oberfläche zunächst mit einem angefeuchteten und ausgedrückten Zelluloseschwamm reinigen.

Mit der Endbearbeitung fortfahren: INSTANT REMOVER gleichmäßig auf die Oberfläche sprühen und 1-2 Minuten je nach der Oberfläche des Materials einwirken lassen.

Mit einem Reibebrett mit feuchtem Schwamm arbeiten und darauf achten, ihn regelmäßig auszuspülen, um ihn sauber zu halten.

Bei hartnäckigen Rückständen nach dem Verfugen 1 eine Stunde nach vorstehenden Anweisungen die Anwendung wiederholen. Zur Inbetriebnahme die Anleitung des Fugenmörtelherstellers beachten.

Achtung: Bei hartnäckigeren Rückständen das Produkt erneut auftragen, die gleiche Vorgehensweise wie bei der ersten Reinigung beachten, aber das Produkt länger wirken lassen. Nicht auf Glanzmarmor-Bodenbelägen oder auf säureempfindlichen Materialien verwenden. Anhand eines Vorab-Tests auf einem kleinen Teilstück der Oberfläche sicherstellen, dass das Material durch das Produkt weder angegriffen noch beschädigt wird. Bei Elementen aus Aluminium das Produkt nach den Gebrauchsanweisungen und mit einem weichen Schwamm einsetzen.

### 1.2. Entfernen von Rückständen mit Epoxid

Für diese Materialien muss der Fliesenleger die Anweisungen und Empfehlungen des Herstellers sowie die technischen und gestalterischen Vorgaben befolgen, die in der Verlegenorm (UNI EN 11493-2016) vorgegeben sind. Es wird geraten, die Erstreinigung mit bestimmten professionellen Reinigungsmitteln durchzuführen, wie z.B.: CR10 der Firma FILA (oder gleichwertigen: EPOSOLV der Firma Geal); oder anderen spezifischen Reinigungsmitteln, die vom Hersteller des Dichtmittels empfohlen werden.

### 2. Endreinigung der Baustelle

Am Ende der Arbeiten auf der Baustelle müssen nach der Erstreinigung alle anderen Verunreinigungen und Verschmutzungen sorgfältig entfernt werden, die bei anderen Arbeiten auf der Baustelle anfallen (Elektriker, Maler usw.). Es wird immer empfohlen, den Boden- und Wandbelag zu schützen, um mechanische Schäden aufgrund des unvermeidlichen Vorhandenseins von harten oder scheuernden Materialien zu vermeiden.

### 3. Gewöhnliche Wartung des Fliesenbelags

Für die tägliche Reinigung empfiehlt Ceramica Fondovalle S.p.A. die Verwendung spezieller Reinigungsmittel für rückstandsarme Keramik entsprechend den Empfehlungen des Herstellers. Es wird daran erinnert, dass das Problem der Bildung von Belägen und Rändern auf allen Arten von Oberflächen auf die mangelnde Entfernung von normalem Schmutz zurückzuführen ist. Schmutz muss immer entfernt und nicht verteilt werden.

## ANWENDUNG

### ANWEISUNGEN ZUR REINIGUNG MIT MASCHINE



Den Schmutz / Staub aufsaugen.

CLEANER PRO 1:200 verdünnen, d.h. 25 ml auf 5 Liter Wasser.

Die Scheuersaugmaschine einstellen und die Oberfläche reinigen.

Die Oberfläche nicht betreten, solange sie nicht vollständig getrocknet ist.

## HINWEISE ZUM MANUELLEN VORGEHEN AUF BODENBELÄGEN

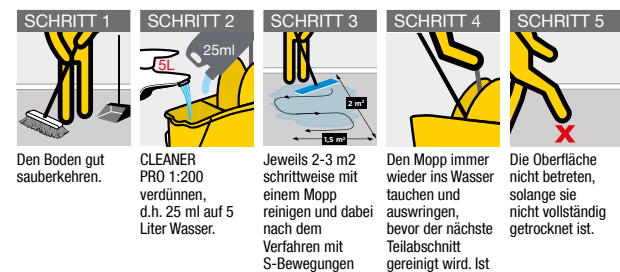

## HINWEISE ZUM MANUELLEN VORGEHEN AUF BODENBELÄGEN, WASCHTISCHPLATTEN IM BAD / ARBEITSPLETTEN IN DER KÜCHE, TISCHEN



Das Produkt CLEAN & SHINE auf die Oberfläche sprühen und die Flasche dabei in einer vertikalen Position etwa 20/30 cm vom Auftragungspunkt entfernt halten.

Den Bereich mit einem weichen Lappen abwischen.

Achtung: Bei hartnäckigeren Rückständen das Produkt erneut auftragen, die gleiche Vorgehensweise wie bei der ersten Reinigung beachten, aber das Produkt länger wirken lassen. Nicht auf Glanzmarmor-Bodenbelägen oder auf säureempfindlichen Materialien verwenden. Anhand eines Vorab-Tests auf einem kleinen Teilstück der Oberfläche sicherstellen, dass das Material durch das Produkt weder angegriffen noch beschädigt wird. Bei Elementen aus Aluminium das Produkt nach den Gebrauchsanweisungen und mit einem weichen Schwamm einsetzen.

Achtung: Bei hartnäckigeren Rückständen das Produkt erneut auftragen, die gleiche Vorgehensweise wie bei der ersten Reinigung beachten, aber das Produkt länger wirken lassen. Nicht auf Glanzmarmor-Bodenbelägen oder auf säureempfindlichen Materialien verwenden. Anhand eines Vorab-Tests auf einem kleinen Teilstück der Oberfläche sicherstellen, dass das Material durch das Produkt weder angegriffen noch beschädigt wird. Bei Elementen aus Aluminium das Produkt nach den Gebrauchsanweisungen und mit einem weichen Schwamm einsetzen.

Zur Erleichterung der Ausführung geben wir nachfolgend die Arten von Werkzeugen an, die für verschiedene Arten von Keramikoberflächen geeignet sind:

- für GLATTE Oberflächen (normale, seidenmatte, glänzende oder geschliffene), FEUCHTES TUCH und / oder FEUCHTER SCOTCH-BRITE ANTISCRATCH (Farben WEISS - besser - oder HELLBLAU);
- für STRUKTURIERTE Oberflächen, FEUCHTER, NICHT SCHEUERNDER SCHWAMM und/oder BÜRSTE MIT FEINEN BORSTEN AUS SORGHUM ODER KUNSTSTOFF;

Das TUCH und der SCHWAMM eignen sich besser für feineren, flüssigeren Schmutz, der SCOTCH-BRITE ANTI-SCRATCH und die BÜRSTE für gröberen Schmutz.

Alle oben genannten Werkzeuge verursachen keine Schäden an Keramikmaterialien, sind jedoch weniger effektiv, wenn sie nicht wie angegeben verwendet werden, obwohl es vorkommen kann, dass sie gleichsam funktionieren. Die Tücher können auch aus Mikrofaser hergestellt sein, was in einigen Fällen aufgrund ihrer unterschiedlichen mechanischen Wirkung, immer in Kombination mit der vorherigen chemischen Behandlung, hilfreich sein kann. Mit einem ähnlichen Prinzip weisen wir auch auf die Möglichkeit hin, Melaminschwämme (oder „Zauber“-Schwämme) zu verwenden, wobei besonders auf matte oder glänzende seidenmatte Materialien zu achten ist, da diese leicht Abasie sind und das ursprüngliche Erscheinungsbild ändern können.

### 4. Außergewöhnliche Wartung des Fliesenbelags

Manchmal kann es erforderlich sein, Flecken zu entfernen, die durch zufällige Ereignisse entstehen, die während der langen Lebensdauer der Fliesen auftreten. In den meisten Fällen wird das Problem mit dem richtigen Reinigungs- und Wartungsprodukt ohne Beschädigung und mühelos gelöst.

Ceramica Fondovalle S.p.A. gewährleistet technische Unterstützung in Reinigungsfragen für die gesamte eigene Produktpalette über den spezialisierten Reinigungsdienstleister FILA. Um den Wünschen und Anforderungen unserer Kunden entgegenzukommen, vertrauen wir auf spezialisierte Partner mit flächendeckendem Vertriebs- und Service-Netz.

Rufen Sie zur Inanspruchnahme des Service die Nummer des Kundendienstes FILA +39 049 946 73 00 unter Angabe von Fondovalle an oder besuchen Sie die Website [www.filasolutions.com](http://www.filasolutions.com)



Programma di sviluppo ambientale | Environmental development programme | Programme de développement environnemental | Umweltentwicklungsprogramm

Il programma LIFE+ è lo strumento finanziario per l’ambiente dell’Unione Europea. L’obiettivo generale del programma LIFE+ è quello di contribuire alla realizzazione, all’aggiornamento e allo sviluppo di politiche ambientali e legislative rilevanti per l’Unione Europea, co-finanziando progetti pilota o dimostrativi di importanza per l’intera Europa. LIFE+ è stata istituito con Regolamento (CE) n. 614/2007 del Parlamento Europeo e del Consiglio del 23/05/2007 ed è la prosecuzione naturale del precedente programma LIFE, entrato in vigore nel 1992.

**Il programma LIFE+ è suddiviso in 3 parti:**

**1. LIFE+ Natura e Biodiversità:** sostiene progetti dimostrativi e migliori pratiche aventi come obiettivo la salvaguardia della natura e della biodiversità europea, per mezzo della conservazione e della protezione degli habitat naturali e delle specie animali e vegetali.

**2. LIFE+ Politiche e Governance ambientale:** sostiene progetti pilota o innovativi che contribuiscano alla realizzazione di politiche ambientali europee e di idee, tecnologie, metodi e strumenti per lo sviluppo di politiche innovative ambientali.

**3. LIFE+ Informazione e Comunicazione:** sostiene progetti relativi allo sviluppo di campagne di comunicazione e sensibilizzazione in merito a tematiche quali la conservazione ambientale, la protezione della natura o la conservazione della biodiversità, così come campagne per la prevenzione degli incendi nelle foreste.

Possono essere reperite maggiori informazioni relative al programma LIFE+ e ai progetti co-finanziati all’indirizzo web istituzionale: <http://ec.europa.eu/environment/life/index.htm>. Ulteriori informazioni relative alle priorità nazionali possono essere reperite sui siti delle autorità nazionali competenti per il LIFE+. Il National Contact Point per l’Italia è il Ministero dell’Ambiente e della Tutela del Territorio e del Mare, sul cui sito web ([www.minambiente.it](http://www.minambiente.it)) si possono trovare sia le informazioni in italiano sul programma LIFE+, sia sui progetti realizzati o in corso di realizzazione in Italia.

Per maggiori dettagli consultare il sito [www.fondovalle.it](http://www.fondovalle.it)

LIFE+ is the European Union’s financial instrument for the environment. The general objective of LIFE+ is to contribute to the implementation, updating and development of EU environmental policy and legislation by co-financing pilot or demonstration projects with European added value. The legal basis for LIFE+ is the Regulation (EC) No 614/2007 of the European Parliament and of the Council dated 23/05/2007 and it is the natural prosecution of the previous LIFE programme which started in 1992.

**The LIFE+ programme is divided in 3 parts:**

**1. LIFE+ Nature and Biodiversity:** it co-finances best practice or demonstration projects that contribute to safeguarding European nature and biodiversity by preserving and protecting the natural habitats of animal and plant species.

**2. LIFE+ Environment policy and governance:** it co-finances innovative or pilot projects that contribute to the implementation of European environmental policy and the development of innovative policy ideas, technologies, methods and instruments.

**3. LIFE+ Information and Communication:** it co-finances projects relating to communication and awareness raising campaigns on environmental, nature protection or biodiversity conservation issues, as well as projects related to forest fire prevention.

For further information about the LIFE+ programme and the projects co-financed visit the institutional website: <http://ec.europa.eu/environment/life/index.htm>. Further information on national priorities can be found on the websites of the competent national authorities as regards LIFE+. The National Contact Point for Italy is the Ministry for the Environment, Land and Sea and its website ([www.minambiente.it](http://www.minambiente.it)) contains information in Italian on the LIFE+ programme and on projects carried out or underway in Italy.

For more details consult our web site [www.fondovalle.it](http://www.fondovalle.it)

## life 15\_eclat

**Nuovo modello di economia circolare che predispone anche l’uso di materiali di scarto di altre aziende e/o settori.**

Il Progetto LIFE ECLAT nasce dalla collaborazione tra la nostra azienda e l’Università degli studi di Modena e Reggio Emilia per integrare in un unico processo aziendale circolarizzato tutte le migliori prassi tecnologiche disponibili o in fase di sviluppo nel settore ceramico.

Iniziato nella seconda metà del 2016, è in fase di sviluppo e inizia ora a dare i primi riscontri concreti.

### Obiettivi

L’obiettivo del progetto è quello di applicare e validare i principi dell’approccio definito come “economia circolare” alla realizzazione di rivoluzionarie lastre ceramiche “infinite” da utilizzarsi come rivestimenti, pavimenti, piani cucina, piatti doccia ecc.

L’intento principale è di chiudere completamente il nostro ciclo di produzione che inizia con l’ingresso della polvere atomizzata e termina con la realizzazione di prodotti finiti, passando per processi meccanici e termici e attraverso il riciclaggio di piastrelle e vetri di scarto (rifiuti di produzione, demolizione ecc).

Il progetto intende unire in un sistema integrato il nuovo processo di formatura in continuo per pressatura a nastro di polveri atomizzate, un sistema di decorazione a secco simile al “getto d’inchiostro”, un successivo taglio a secco e levigatura in verde: in questo modo tutti i possibili scarti generati durante le lavorazioni fin qui descritte saranno assimilabili alle materie prime di partenza e pertanto riutilizzabili direttamente nello stesso processo di fabbricazione. Questa innovazione estende i suoi effetti anche verso la restante parte del ciclo produttivo, nella quale il processo di cottura risulterà più uniforme e quindi presenterà meno rischi di difetti, imperfezioni o rotture, essendo le lastre di dimensioni maggiori e costanti. Infine il sistema di packaging si è stato modificato in modo da evitare qualsiasi generazione di rifiuti o il consumo di risorse: l’imballo è prodotto in loco e “on demand”, partendo da rulli di cartone che vengono tagliati a misura, piegati e sui quali viene di volta in volta stampato il necessario; il packaging verrà studiato per coprire solo i lati e parte delle superfici superiore ed inferiore della scatola così da avere protezione solo dove necessario e risparmiare materiale inutile. In questo caso si avrà una riduzione del 60-70% nell’utilizzo del cartone per imballaggio rispetto al processo tradizionale.

Ultimo ma non meno importante, le nuove lastre verranno realizzate con una “marca” (ovvero la superficie inferiore) più liscia che renderà le procedure sia di Installazione che di smontaggio più semplice. La composizione del corpo ceramico sarà realizzata utilizzando nuove “eco” composizioni, che conterranno fino al 40% di materiali riciclati provenienti da piastrelle di terra ceramica o porcellana; a sua volta, lo stesso prodotto a fine vita potrà essere completamente riciclato nelle stesse composizioni, chiudendo la circolarità del processo.

### Risultati attesi

I risultati attesi sono principalmente di natura ambientale e tecnica. In particolare si prevede di applicare pienamente i principi di economia circolare che saranno dimostrati attraverso la predisposizione della linea pilota che sarà realizzata presso la sede del proponente.

In particolare ci aspettiamo di ottenere:

- Nessuna rifiuto solido o liquido emesso dal nuovo processo e completo riciclo interno dei rifiuti prodotti. Ciò corrisponde ad una riduzione di 0,9 kg/m<sup>2</sup> di fanghi di taglio e levigatura (valore calcolato su base secca) attualmente smaltiti in discariche e di circa 2,5 kg/m<sup>2</sup> di scarti cotti (rotture che accadono durante le operazioni di taglio o a causa di lastre difettose).
- Nessun uso di acqua nelle operazioni di taglio e levigatura (tutto avverrà in verde e quindi a secco), portando ad un risparmio di 0,8 metri cubi di acqua per metro quadrato di lastra prodotta.
- Minor consumo energetico: -50% nel taglio e levigatura, +40%/+90% di vita utile delle mole da taglio/levigatura; nessun aumento di consumi energetici dovuti al cambio di tecnologia in fase di pressatura. In valori assoluti, il risparmio dei consumi energetici è stato stimato in circa -1,13 kWh/m<sup>2</sup> di prodotto (24.180 kWh/anno\*).

- Uso di materie riciclate (comprese ceramiche recuperate da demolizioni) fino al 40% in peso dell’impasto (9,2 kg/m<sup>2</sup>, pari a 358,8 tonnellate/anno\*).
- Riciclabilità completa del prodotto a fine vita e reinserimento nel processo di fabbricazione.
- Riciclaggio completo tal quale delle polveri prodotte durante il taglio e la levigatura in verde, per semplice rimescolamento e reinserimento nell’impasto base. In cifre, il riciclaggio interno (vd. punti 5 e 6) può calcolarsi pari a 2,31 kg/ m<sup>2</sup>, ovvero a 90 tonnellate/anno\*.
- Aumento della produttività (atteso di circa il 30%) nelle operazioni di taglio e lucidatura, a causa della minore resistenza all’usura delle lastre pressate rispetto a quelle sinterizzate.
- Riduzione dei costi derivanti dalle operazioni di confezionamento, stimati nel 40% in meno (valore riferito ad una lastra media di 1 m<sup>2</sup> di superficie) dovuti dalla riduzione nell’uso di cartone ed al sistema di stampa diretta sulla confezione (-2 m<sup>2</sup> di imballaggio per m<sup>2</sup> di prodotto, pari a 7800 confezioni m<sup>2</sup>/anno\*).
- Riduzione delle emissioni di CO<sup>2</sup>: fino a 13.74 kg/m<sup>2</sup> di prodotto (430 tonnellate di CO<sup>2</sup>/anno\*).

\* indica la stima per una linea dimostrativa dalla capacità produttiva di 130 m<sup>2</sup>/giorno, operativo 300 giorni all’anno.

**New model of circular economy that also predisposes the use of waste materials in other industries.**

LIFE PROJECT ECLAT arise from the collaboration between our company and the University of Modena and Reggio Emilia in order to integrate in a whole circularized process all the best technological practices available or under development in the ceramic field.

Started during the second half of the 2016, is under development and start now to externalize first findings.

### Objectives

The objective of the project is to apply and validate the principles of the circular economy approach to the manufacturing of endless revolutionary ceramic slabs for tiles, kitchen tops, bathroom countertops.

The aim is to completely close the manufacturing cycle, which starts from the incoming atomized powders, leading to the finished products by means of mechanical and thermal processes, up to the recycling of end of life products claimed by deconstruction operations or production waste.

The project intend to joint in an integrated system the new forming process using belt pressing of atomised powders, a decoration plant using a new dry like inkjet system, a subsequent dry cutting and in green polishing: so all the possible waste generated during the processes till now described should be comparable to starting raw materials and therefore reusable directly in the same productive cycle. This innovation will extend also down to the manufacturing cycle, since the sintering cycle will result more uniform and the will be minimized risk of defects, imperfections, breakages, being the slabs with higher and constant dimensions. Packaging itself has been revised in order to avoid any generation of waste or resources consumption: the package is produced on site and on demand, starting from cardboard rollers which are cut to size, folded and printed, but covering only part of the sides and of the top part of the finished slab, approximately a reduction of 60-70% of the cardboard used for normal packaging.

Last but not least, the new slabs, will have a smoother back side, which will make easier both installation and disinstallation procedures, using glues or mechanical fixtures. The ceramic body composition will be realized using new “eco” compositions, that will contain up to 40% of recycled materials deriving mainly from ground ceramic tiles or porcelain; hence the final product, when its useful life has come to end, could be completely recycled in the same “eco” compositions, closing the circularity of the process.

### Expected results

The expected results are mainly of environmental and technical nature, and in particular it is expected that the principles of the circular economy are fully implemented in the demonstrative line which will be set at the proposer’s site:

- No solid or liquid waste emitted by the new process and complete internal recycling of the produced waste. This will correspond to a reduction of 0.9 kg/m<sup>2</sup> of cutting and polishing sludge (on a dry base), currently disposed of in dumps, and of approx 2.5 kg/m<sup>2</sup> of fired scraps (broken during cutting, defective slabs).
- No water use in finishing operations (green cutting, green polishing), leading to savings of 0.8 cubic metres of water saved per square metre of slabs.
- Lower energy consumption, estimated in less than 50% energy consumption in cutting and polishing, with at least 40% longer diamond wheel life and 90% longer mole life; no specific energy consumption increase during forming (pressing) operations. In figures, energy consumption saving has been estimated in -1,13 kWh/m<sup>2</sup> of product (24.180 kWh/year\*)
- Use of up to 40% of recycled raw materials, including reclaimed end of life slabs deriving from dismantling of existing installations (9,2 kg/m<sup>2</sup>, equivalent to 358,8 tonnes/year\*)
- Complete recyclability of the final product and its reinsertion in the manufacturing process, requiring only milling operations.
- Full recycling, as it is, of the powder produced during green cutting and green polishing, by simple re-mixing and repressing in the base material. In figures, internal recycling (points 5 and 6) can amount to 2,31 kg/m<sup>2</sup>, equivalent to 90 tonnes/year\*
- Productivity increase (30% expected) in cutting and polishing operations, due to the lower wear resistance of the pressed slabs with respect to the sintered ones.
- Cost saving in packaging operation, estimated in 40% less for an average 1x1 metre slab, deriving from the reduction of cardboard use and direct printing on the envelope (-2 m<sup>2</sup> of packaging per m<sup>2</sup> of product, equivalent to 7800 m<sup>2</sup> packaging/year\*).
- Reduction of CO<sup>2</sup> emissions: down to 13.74 kg/m<sup>2</sup> of product (430 tonnes of CO<sup>2</sup>/year\*)

\* estimation for a demonstrative line of 130 m<sup>2</sup>/day operating 300 days/year



# condizioni generali di vendita

General terms of sale | Conditions generales de vente | Allgemeine verkaufsbedingungen

**1. Normativa Contrattuale**

Le presenti condizioni generali, salvo eventuali modificazioni o deroghe concordate per iscritto, disciplinano tutti i contratti di vendita fra noi e l’acquirente, quindi tanto il contratto concluso con l’accettazione del presente ordine che qualsiasi contratto futuro relativo alle forniture dei prodotti della nostra società ordinati con successive e distinte commissioni. Le variazioni delle condizioni generali di vendita, le offerte, le transazioni, gli accrediti o gli abbuoni dai nostri Agenti o altri intermediari, non sono validi se non accettati per iscritto dalla nostra sede e sono comunque limitati ai contratti cui si riferiscono.

**2. Oggetto della Fornitura**

La fornitura comprende solamente le prestazioni, i materiali ed i quantitativi specificati nella nostra conferma d’ordine o in altre comunicazioni scritte provenienti da noi. Il testo della nostra conferma d’ordine prevarrà in ogni caso sul testo difforme della eventuale offerta o della ordinazione. L’esecuzione parziale dell’ordine senza preventiva conferma non significa nostra approvazione per l’intero ordine, bensì approvazione parziale relativamente alla merce consegnata. In questo caso la consegna della merce al vettore equivarrà ad accettazione da parte dell’acquirente della nuova proposta contrattuale.

**3. Conferma d’Ordine**

Qualora nella nostra conferma d’ordine esistano differenze nei singoli elementi che la compongono rispetto alle intese o alle ordinazioni, il compratore che non abbia contestato tali differenze con lettera raccomandata spedita entro dieci giorni dalla ricezione della conferma, è tenuto ad accettarla così come è stata redatta.

**4. Consegne**

La merce è di norma consegnata “franco-magazzini Ceramica Fondovalle”, anche se venduta “franco arrivo” o “franco domicilio del compratore”, viaggia a rischio e a pericolo di quest’ultimo ed ogni nostra responsabilità cessa con la consegna al vettore, nei confronti del quale il compratore - effettuate le opportune verifiche – dovrà sporgere eventuali reclami. L’appuntamento della merce, semprechè disponibile al momento dell’ordine, e fatto salvo quanto previsto al punto 1, non potrà essere richiesto prima di 3 giorni lavorativi dal ricevimento da parte nostra dell’ordine stesso. Le spedizioni, via mare o via terra, concernenti forniture sull’estero, vengono effettuate in base alle condizioni scelte di volta in volta, riportate negli “Incoterms” approvati dalla Camera di Commercio Internazionale nel 1990 e nei successivi.

**5. Termini di Consegna**

I termini di consegna decorrono dal giorno della conclusione del contratto e, salvo espressa pattuizione scritta, devono considerarsi non strettamente vincolanti. Se espressi in numero di giorni, si intendono riferiti a giorni lavorativi. In caso di ritardo, anche parziale, nella consegna, il Compratore avrà diritto di annullare soltanto la parte dell’ordine relativa alla merce non consegnata dandone comunicazione a Ceramica Fondovalle Spa a mezzo raccomandata con avviso di ricezione entro 45 giorni dalla scadenza del termine. Tuttavia tale comunicazione resterà senza effetto qualora Ceramica Fondovalle Spa, entro 30 giorni lavorativi dal ricevimento della comunicazione, consegni tutti i prodotti ordinati. E’ comunque esclusa ogni responsabilità di Ceramica fondovalle Spa per danni derivanti da ritardo o mancata consegna (totale o parziale)della merce, salvi i casi di dolo o colpa grave. Quando siano intervenute modificazioni del contratto, il termine resta prorogato per un periodo uguale a quello inizialmente stabilito. Ogni causa di forza maggiore sospende la decorrenza del termine per tutta la durata della causa stessa.

**6. Pagamenti**

Il luogo di pagamento è fissato presso la nostra sede Amministrativa in Maranello frazione Torre Maina (MO) anche nel caso di emissione di tratte o ricevute bancarie, ovvero di rilascio di effetti cambiari: eventuale deroga a quanto sopra sarà valido soltanto se da noi concessa in forma scritta. Per le fornitore di materiali di importo inferiore a 1.000 euro, verrà emessa ricevuta bancaria con scadenza a 60 gg dalla data fattura, Iva compresa, indipendentemente dalle normali condizioni riservate all’acquirente. Per i pagamenti previsti in più rate, l’importo dell’Iva sarà comunque riscosso a

mezzo ricevuta bancaria con scadenza a 30 giorni dalla fattura. Il ritardo del pagamento, anche parziale, delle nostre fatture oltre la pattuita scadenza, darà luogo come previsto per legge all’immediata decorrenza degli interessi di mora, calcolati al tasso del 8% annuo. Inoltre il mancato o ritardato pagamento, anche parziale delle fatture, - per qualsivoglia ragione – ci darà diritto impregiudicata ogni altra iniziativa, di pretendere il pagamento anticipato delle restanti forniture. Il mancato o ritardato pagamento, anche parziale, del prezzo o del corrispettivo nei termini pattuiti è causa di risoluzione ex art. 1456 cod.civ. del contratto cui si riferisce e giustifica in goni caso, ex art. 1460 del Cod. Civ., il rifiuto di adempiere eventuali ulteriori obbligazioni contrattuali e di annullare l’evasione di eventuali altri ordini in corso, senza che il compratore, possa avanzare pretesi di compensi, indennizzi o altro.

**7. Solve et Repete**

Nessuna eccezione, salvo quelle di nullità, annullabilità e rescissione del contratto, può essere opposta all’acquirente, al fine di ritardare o evitare il pagamento.

**8. Riserva di Proprietà**

Nel caso in cui il pagamento, per accordi contrattuali, debba essere effettuato – in tutto o in parte – dopo la consegna, i prodotti consegnati restano di proprietà di Ceramica Fondovalle Spa fino all’integrale pagamento del prezzo.

**9. Garanzia e relativa clausola compromissoria**

I nostri materiali sono garantiti conformi alle norme UNI-DIN-EN attualmente in vigore. La nostra garanzia è limitata ai materiali di prima scelta, con tolleranza del 5% circa. Qualsiasi garanzia per vizi rimane quindi espressamente esclusa per i materiali di seconda e terza scelta o di stock e per le partite occasionali. Le collezioni di Ceramica Fondovalle sono materiali soggetti a variazioni cromatiche come espressamente indicato sui nostri cataloghi. Controllare e miscelare il materiale prima della messa in opera. Non si accettano contestazioni per il materiale posato. Eventuali reclami e contestazioni dovranno essere notificati, a pena di decadenza, a mezzo lettera raccomandata, unicamente presso la nostra Sede Amministrativa di Torre Maina, prima della posa in opera del materiale e comunque entro il termine perentorio di giorni otto dalla ricezione del materiale e in ogni caso prima della sua successiva vendita a terzi. La posa in opera del materiale determina la decadenza dell’azione per vizi tanto palesi che occulti, importando rinuncia implicita alla garanzia di cui all'art. 1490 c.c. Le differenze di tonalità non possono essere denunciate come vizio del materiale. In ogni caso la nostra garanzia comprende unicamente la sostituzione del materiale riscontrato difettoso con esclusione di ogni ulteriore e diversa obbligazione. Eventuali contestazioni sul materiale non daranno diritto all’Acquirente di sospendere o ritardare in tutto o in parte il pagamento nei termini pattuiti, ai sensi del precedente articolo 7. Ogni questione relativa all’accertamento dei vizi, del diritto alla garanzia, alla determinazione del danno e alla sua quantificazione che non possa essere bonariamente risolta tra le parti sarà rimessa ad arbitrato irrituale con arbitro unico da costituirsi e svolgersi secondo il regolamento della Camera Arbitrale Ceramica istituita presso il Centro Ceramico di Bologna che le parti dichiarano di accettare incondizionatamente ed inappellabilmente.

**10. Foro Competente**

Fermo restando quanto previsto al punto 9, foro esclusivamente competente per tutte le controversie sarà il Foro di Modena.

**11. Effettività di ciascuna condizione**

Le condizioni generali di vendita sopra riportate non devono assolutamente intendersi come clauseole di puro stile. Esse sono effettive e rappresentano fedelmente la volontà negoziale delle parti.

**1. Regulation of Agreement**

Except in the event of amendments or exceptions agreed upon in writing, the general conditions hereunder shall govern all sales agreement between ourselves and the purchaser, and therefore both the agreement entered into with the acceptance of the order hereunder and any other agreements entered into in the future relating to products produced by our company and ordered at a future date. Changes in the general conditions of sale, offers, negotiations, credits or rebates put into practice by our Agents or other intermediaries are not valid unless accepted in writing by our head office and, in any case, are limited solely to the agreements concerned thereby.

**2. Scope of the supply**

The supply comprises solely the services, materials, and quantities specified in our order confirmation or in any other written notification sent by ourselves. In the event of discrepancies between the wording of the offer and the order, the wording of our order confirmation shall prevail. Partial processing of the order without prior confirmation shall not constitute our approval of the entire order, simply partial approval relating to the goods delivered. In this case, delivery of the goods to the carrier shall constitute acceptance by the purchaser of the new agreement proposal.

**3. Order Confirmation**

If our order confirmation contains differences between the individual items included and the agreements or orders which the purchaser fails to dispute with a recorded delivery letter sent within ten days of receipt of the confirmation, the purchaser shall accept the confirmation as it stands.

**4. Deliveries**

The goods are usually delivered ex warehouse at the Ceramica Fondovalle warehousing facilities, even if sold CP or CPT purchaser’s works, shall travel at the latter’s risk and peril and all our responsibility in relation to the purchaser ceases upon delivery to the carrier. The latter shall then carry out the appropriate checks and, in the event, file the relative claims. Assuming the goods are available when the order is placed, and without prejudice to the provisions of Article 1 hereinabove, the preparation of such goods may not be requested until 3 working days after we have received the said order. Shipments sent abroad, either by sea or by ground, shall be governed by the conditions chosen as and when from the Incoterms approved by the International Chamber of Commerce in 1990, or in subsequent versions.

**5. Delivery terms**

The delivery terms apply from the day on which the agreement is entered into and, unless expressly agreed in writing, shall be deemed not strictly binding. If expressed in terms of number of days, such days are understood as working days. In the event of delays in delivery, the purchaser shall be entitled to cancel solely the part of the order concerning the goods not yet delivered, giving Ceramica Fondovalle S.p.A. notice thereof via recorded delivery letter with advice of receipt within 45 days of the expiry of the delivery term. Nevertheless, this notification shall remain without effect if Ceramica Fondovalle S.p.A. delivers all the products ordered within 30 working days of receipt thereof. In any case, Ceramica fondovalle S.p.A. cannot be held in any way liable for damage originating from delays in delivery or failure to deliver the goods (whether totally or partially), with the exception of cases of wilful misconduct or gross negligence. When they agreement has been amended, the term shall be extended by the same amount as that originally established. Any events of force majeure shall interrupt the term for the duration of the said event.

**6. Payments**

The place of payment is hereby established as our administrative premises in Torre Maina, Maranello (Modena), even in the event of issue of bank drafts or direct debits (without or without the crediting of the sum prior to collection), or of bills of exchange; any exception to the foregoing shall be valid solely if granted by ourselves in writing. For supplies of materials amounting to less than €1,000, a direct debit shall be set up with payment due 60 days from the invoice date, including VAT, regardless of the conditions normally reserved for the purchaser. For payments in instalments, the amount shall be collected via direct debit payable 30 days from the invoice date. Any delays in the payment,

even partial, of our invoices beyond the agreed expiry date shall result in the immediate application of the interest on arrears envisaged by law, calculated at a yearly rate of 8%. Furthermore, failure to pay or delays in payment of the invoices, even partly – for whatsoever reason it may occur - shall entitle us to claim the early payment of the other supplies, without prejudice to any further action we may deem appropriate. Failure to pay or delays in payment of the prices agreed, even partly, within the terms agreed, shall constituted grounds fro termination of the agreement concerned, pursuant to Article 1456 of the Italian Civil Code, and shall validate – pursuant to Article 1460 of the Italian Civil Code - in any case - the refusal to fulfil further contractual obligations and to cancel any other pending orders, in which case the purchaser cannot file any claims for remuneration, compensation, or other such.

**7. Solve et Repete (pay and then claim)**

With the exception of the voidness or voidability or the agreement or of withdrawal therefrom, no objections may be laid against the purchaser in order to delay or avoid payment.

**8. Ownership reservation**

In the event that, due to contractual arrangements, payment is required - either in full or in part - after delivery, the products delivered shall remain our property until the payment in full of the price thereof.

**9. Warranty and relative arbitration clause**

Our materials are guaranteed in compliance with UNI-DIN-EN standards currently in force. Our guarantee only covers first-class products, with a fault tolerance of approximately 5%. Any guarantee concerning faults is therefore expressly excluded for second and third-class materials or old stock materials and for any non-compliant batches. The final colours of the Ceramica Fondovalle collections may vary, as clearly stated in our catalogues. Always check and mix the material before laying. We do not accept claims for materials that have already been laid. For claims and disputes to be taken into account, the Purchaser is required to inform Ceramica Fondovalle thereof via recorded delivery letter, sent solely to our administrative premises in Torre Maina, before laying the material and, in any case, within the binding term of 8 days of receipt of the material and prior to the subsequent resale thereof to third parties. Laying the material shall result in the forfeiture of the right to take action for obvious and hidden defects, and thus the implicit waiver of the warranty envisaged in Article 1490 of the Italian Civil Code. Differences in shade cannot be claimed to be a flaw in the material. In any case, our guarantee comprises solely the replacement of material found to be faulty, with any further, different obligations hereby expressly excluded. Any disputes concerning the material shall not entitle the purchase to withhold or delay payment of the amount due, or part thereof, within the terms agreed pursuant to Article 7 hereinabove. Any matter concerning the ascertainment of defects, the right to the warranty, and the establishment and quantification of damage not settled amicably by the parties, shall be settled by a sole arbitrator, with the arbitration proceeding to be established and run according to the Chamber of Arbitration set up at the Ceramic Centre in Bologna, whose decision the parties hereby declare they shall accept unconditionally and unappealably.

**10. Competent authority**

Without prejudice to the provisions of Article 9 hereinabove, the solely authority with jurisdiction to settle all disputes relating to hereto is the Court of Modena.

**11. Validity of each condition**

The general conditions of sale set out hereinabove shall not be considered merely formalities. They are both valid and faithfully representative of the contractual intent of the parties.



# condizioni generali di vendita

General terms of sale | Conditions generales de vente | Allgemeine verkaufsbedingungen

#### 1. Réglementation Contractuelle

Sous réserve de modifications ou de dérogations éventuelles établies par écrit, les présentes conditions générales règlentent tous les contrats de vente entre notre société et l’acheteur, c’est-à-dire le contrat conclu avec l’acceptation de la présente commande et tout contrat futur relatif aux fournitures des produits de notre société commandés à l’occasion de commandes successives et distinctes. Les variations des conditions générales de vente, les offres, les transactions, les crédits et les ristournes de la part de nos Agents ou autres intermédiaires, ne sont pas valables s’ils n’ont pas été acceptés par écrit par notre siège, et ils sont quoi qu’il en soit limités aux contrats auxquels ils se réfèrent.

#### 2. Objet de la Fourniture

La fourniture comprend uniquement les prestations, le matériel et les quantités spécifiées dans notre confirmation de commande ou dans d’autres communications écrites provenant de nos bureaux. Le texte de notre confirmation de commande prévaudra toujours sur le texte non conforme de l’éventuelle offre ou de la commande. L’exécution partielle de la commande sans confirmation préalable n’exprime pas notre approbation relative à toute la commande, mais elle représente une approbation partielle concernant la marchandise livrée. Dans ce cas, la remise de la marchandise au transporteur équivaldra à l’acceptation de la part de l’acheteur de la nouvelle proposition de contrat.

#### 3. Confirmation de Commande

Si notre confirmation de commande présente des différences au niveau des différents éléments qui la constituent par rapport aux accords et aux commandes, l’acheteur qui n’a pas contesté ces différences par lettre recommandée expédiée dans un délai de 10 jours à compter de la réception de la confirmation, est tenu de l’accepter telle qu’elle a été rédigée.

#### 4. Livraisons

La marchandise est généralement livrée “franco-entrepôts Ceramica Fondovalle”, même si elle a été vendue “franco destinataire” ou “franco domicile de l’acheteur”, elle est transportée aux risques et périls de ce dernier et toute responsabilité de notre part prend fin avec la remise au transporteur, envers lequel l’acheteur - après avoir effectué les vérifications nécessaires - devra présenter les éventuelles réclamations. La préparation de la marchandise, à condition qu’elle soit disponible au moment de la commande, et sans préjudice du contenu du point 1, ne pourra pas être demandée avant trois jours ouvrables à compter de la réception de la commande de notre part. Les expéditions maritimes et terrestres concernant les fournitures à l’étranger, sont effectuées en fonction des conditions choisies au fur et à mesure, indiquées dans les “Incoterms” approuvés par la Chambre de Commerce Internationale en 1990 et successifs.

#### 5. Délais de Livraison

Les délais de livraison prennent effet à compter du jour de la conclusion du contrat et, sauf accord écrit spécifique, ils sont réputés non strictement contraignants. S’ils sont exprimés en nombre de jours, ils se réfèrent à des jours ouvrables.

En cas de retard de livraison, même partiel, l’Acheteur aura le droit d’annuler uniquement la partie de la commande relative à la marchandise non livrée en le communiquant à Ceramica Fondovalle Spa par lettre recommandée avec avis de réception dans un délai de 45 jours à compter de l’échéance du délai. Toutefois, cette communication n’aura aucun effet si Ceramica Fondovalle Spa livre tous les produits commandés dans un délai de 30 jours ouvrables à compter de la réception de la communication. Ceramica fondovalle Spa est quoi qu’il en soit déchargée de toute responsabilité en cas de dommages dérivant d’un retard ou d’une livraison manquée (totale ou partielle) de la marchandise, sauf en cas de dol ou de faute grave. En cas de modifications du contrat, le délai reste prorogé pour une période égale à celui établi au départ. Toute cause de force majeure suspend l’échéance du délai pendant toute la durée de la cause.

#### 6. Paiements

Le lieu de paiement est fixé en notre siège Administratif à Torre Maina, Maranello (Modène) également en cas d’émission de traites ou de reçus bancaires, ou de délivrance d’effets de change : toute dérogation éventuelle

à ce qui précède ne sera valable que si nous y avons consenti par écrit. Pour le fournisseur de matériel d’un montant inférieur à 1000 euros, on émettra un reçu bancaire avec échéance à 60 j. à compter de la date de la facture, TTC, indépendamment des conditions normales réservées à l’acheteur. Pour les paiements prévus en plusieurs échéances, le montant de la TVA sera quoi qu’il en soit encaissé moyennant un reçu bancaire avec échéance à 30 jours à compter de la facture. Le retard du paiement, même partiel, de nos factures outre l’échéance convenue, donnera lieu, tel que le prévoit la loi italienne, à l’échéance immédiate des intérêts de retard, calculés au taux annuel de 8 %. En outre, le non-paiement ou le paiement retardé, même partiel, des factures, - pour quelque raison que ce soit - nous donnera le droit, sans préjudice de toute autre initiative, de prétendre le paiement anticipé des fournitures restantes. Le non-paiement ou le paiement retardé, même partiel, du prix ou de la contrepartie dans les délais établis constitue une cause de résiliation en vertu de l’art. 1456 du Code Civil italien, du contrat auquel il se réfère et justifie quoi qu’il en soit, en vertu de l’art. 1460 du Code Civil italien, le refus d’accomplir d’autres obligations contractuelles éventuelles et l’annulation du traitement des autres commandes éventuelles en cours, sans que l’acheteur ne puisse avancer de prétentions de rétribution, d’indemnisation ou autre.

#### 7. Solve et Repete

Aucune exception, sauf celle de la nullité, de l’annulabilité et la résiliation du contrat, ne peut être opposée à l’acheteur, afin de retarder ou d’éviter le paiement.

#### 8. Réserve de Propriété

Si, en vertu d’accords contractuels, le paiement doit être effectué - entièrement ou en partie - après la livraison, les produits livrés restent notre propriété jusqu’au paiement intégral du prix.

9. Garantie et clause compromissoire correspondante

Notre matériel est garanti conforme aux normes UNI-DIN-EN actuellement en vigueur. Notre garantie est limitée au matériel de premier choix, avec une tolérance d’environ 5 %. Toute garantie couvrant les vices reste donc expressément exclue pour le matériel de deuxième et troisième choix ou de stock et pour les lots occasionnels. Les collections de Ceramica Fondovalle peuvent subir des variations chromatiques telles qu’on l’indique expressément dans nos catalogues. Contrôler et mélanger le matériel avant la pose. Aucune contestation ne sera acceptée concernant le matériel posé. Les éventuelles réclamations et contestations devront être notifiées, sous peine de déchéance, par lettre recommandée, uniquement en notre Siège Administratif de Torre Maina, avant la pose du matériel et quoi qu’il en soit dans un délai impératif de 8 jours à compter de la réception du matériel et quoi qu’il en soit avant sa vente successive à des tiers. La pose du matériel détermine la déchéance de toute action contre des vices manifestes et cachés, impliquant le renoncement implicite à la garantie visée à l’art. 1490 du Code Civil italien. Les différences de tonalité ne peuvent pas être déclarées comme un défaut du matériel. Quoi qu’il en soit, notre garantie comprend uniquement le remplacement du matériel défectueux, toute autre obligation étant exclue. D’éventuelles contestations relatives au matériel ne donneront pas le droit à l’Acheteur de suspendre ou de retarder entièrement ou en partie le paiement dans les délais convenus, en vertu de l’article 7. Toute question relative à la constatation des défauts, au droit à la garantie, à la détermination du dommage et à sa quantification ne pouvant pas être résolue à l’amiable entre les parties sera déférée à l’arbitrage libre d’un arbitre unique, qui sera constitué et qui se déroulera suivant le règlement de la Chambre d’Arbitrage institué au Centre Céramique de Bologne que les parties déclarent accepter sans conditions et sans appel.

#### 10. Tribunal Compétent

Sans préjudice des dispositions du point 9, le tribunal exclusivement compétent pour toutes les controverses est celui de Modène.

#### 11. Efficacité de chaque condition

Les conditions générales de vente indiquée ci-dessus ne sont en aucun cas des clauses de pur style. Elles sont effectives et représentent fidèlement la volonté de négociation des parties.

#### 1. Vertragliche Vorschriften

Die vorliegenden Allgemeinen Geschäftsbedingungen, unter dem Vorbehalt eventueller schriftlich vereinbarter Änderungen oder Ausnahmen, regeln alle Kaufverträge zwischen uns und dem Käufer, d.h. sowohl den mit der Annahme des vorliegenden Auftrags abgeschlossenen Vertrag als auch jeden zukünftigen Vertrag für die Lieferungen der Produkte unserer Gesellschaft, die mit anschließenden und getrennten Bestellungen bestellt wurden. Die Änderungen der Allgemeinen Geschäftsbedingungen, die Angebote, die Geschäfte, die Gutschriften oder die Rabatte unserer Agenten oder anderer Vermittler sind ungültig, wenn sie nicht schriftlich von unserer Gesellschaft akzeptiert wurden und sind auf jeden Fall auf die Verträge beschränkt, auf die sie sich beziehen.

#### 2. Liefergegenstand

Die Lieferung enthält ausschließlich die Leistungen, die Materialien und Mengen, die in unserer Auftragsbestätigung oder anderen, von uns kommenden Mitteilung angegeben sind. Der Text unserer Auftragsbestätigung hat auf jeden Fall Vorrang im Vergleich zum abweichenden Text des eventuellen Angebots oder der Bestellung. Die Teilabwicklung des Auftrags, ohne eine vorherige Bestätigung, stellt nicht unsere Annahme des gesamten Auftrags dar, sondern die Teilannahme für die gelieferte Ware. In diesem Fall ist die Übergabe der Ware an den Spediteur gleichbedeutend mit der Annahme seitens des Käufers des neuen Vertragsvorschlags.

#### 3. Auftragsbestätigung

Sollten in unserer Auftragsbestätigung Unterschiede bei den einzelnen Elementen, aus denen sie besteht, im Vergleich zu den Vereinbarungen oder Bestellungen vorhanden sein, muss der Käufer, der diese Unterschiede nicht innerhalb von zehn Tagen nach Eingang der Auftragsbestätigung per Einschreiben reklamiert hat, die Auftragsbestätigung so akzeptieren, wie sie ausgestellt wurde.

#### 4. Lieferungen

Die Ware wird in der Regel “ab Lager Ceramica Fondovalle” geliefert, selbst wenn sie “frei Empfangsort” oder “frei Donnizil des Käufers” verkauft wurde, und wird auf Risiko und Gefahr des Käufers transportiert und jede Haftung unsererseits endet mit der Übergabe an den Spediteur. Bei diesem muss der Käufer - nach Durchführung angemessener Kontrollen - eventuelle Reklamationen anmelden. Die Bereitstellung der Ware, vorausgesetzt, dass sie im Moment der Bestellung verfügbar ist, und unter dem im Punkt 1 vorgesehenen Vorbehalt, kann nicht vor Ablauf von 3 Arbeitstagen nach Auftragseingang bei uns verlangt werden. Der Versand per Seefracht oder per Lkw bei Lieferungen ins Ausland wird auf der Grundlage der jeweils gewählten Bedingungen vorgenommen, die in den “Incoterms” aufgeführt sind, welche im Jahre 1990 und den anschließenden Jahren von der Internationalen Handelskammer verabschiedet wurden.

#### 5. Lieferzeiten

Die Lieferzeiten beginnen am Tag des Vertragsabschlusses und sind, außer bei ausdrücklichen schriftlichen Vereinbarungen, als nicht streng bindend anzusehen. Wenn sie in einer Anzahl von Tagen ausgedrückt werden, beziehen sie sich auf Arbeitstage. Bei einer auch teilweisen Verspätung der Lieferung darf der Käufer ausschließlich den Teil des Auftrags annullieren, der die nicht gelieferte Ware betrifft und muss die Fa. Ceramica Fondovalle Spa per Einschreiben mit Rückschien innerhalb von 45 Tagen nach Ablauf des Termins darüber benachrichtigen. Diese Mitteilung wird aber keine Auswirkung haben, wenn die Fa. Ceramica Fondovalle Spa innerhalb von 30 Arbeitstagen nach Eingang der Mitteilung alle bestellten Produkte ausliefert. Es ist auf jeden Fall jegliche Haftung seitens der Fa. Ceramica Fondovalle Spa ausgeschlossen für Schäden, die durch die verspätete oder fehlende Lieferung (gesamt oder zum Teil) der Ware verursacht werden, außer in Fällen von Vorsatz oder grob fehlerhaftem Verhalten. Wenn Änderungen am Vertrag vorgenommen wurden, wird der Termin um den gleichen Zeitraum verlängert, der anfänglich vereinbart worden ist. Jeder Fall von höherer Gewalt unterbricht den Ablauf des Termins für den gesamten Zeitraum, in dem die höhere Gewalt vorhanden ist.

#### 6. Zahlungen

Der Zahlungsort ist unser Verwaltungssitz in Torre Maina, Maranello (MO), auch bei Ausstellung von Tratten oder bei Bankeinzügen bzw. bei Ausstellung von Wechseln. Eventuelle Ausnahmen vom o.g. Punkt sind nur nach

schriftlicher Genehmigung von uns gültig. Für Materiallieferungen mit einem Betrag unter 1.000 Euro wird eine Bankeinzugsermächtigung, mit einer Frist von 60 Tagen nach Rechnungsdatum, einschließlich MwSt., ausgestellt, unabhängig von den normalen, dem Käufer gewährten Bedingungen. Bei Zahlungen für die mehrere Raten vorgesehen sind, wird der Betrag der Mehrwertsteuer auf jeden Fall über den Bankeinzug, mit einer Frist von 30 Tagen nach Rechnungsdatum, eingezogen. Die verspätete Zahlung, auch nur zum Teil, unserer Rechnungen, über das Verfalldatum hinaus, führt, wie gesetzliche vorgesehen, zur unverzüglichen Belastung der Verzugszinsen, die mit einem Prozentsatz von 8%/Jahr berechnet werden. Die fehlende oder verspätete Zahlung, auch nur zum Teil, der Rechnungen - aus gleich welchem Grund - gibt uns das Recht, unter dem Vorbehalt weiterer Initiativen, die Vorauszahlung der verbleibenden Lieferungen zu verlangen. Die fehlende oder verspätete Zahlung, auch nur zum Teil, des Preises oder des Betrags innerhalb der vereinbarten Fristen bewirkt nach Art. 1456 ital. BGB die Auflösung des Vertrags, auf den sich die Zahlung bezieht, und rechtfertigt auf jeden Fall nach Art. 1460 ital. BGB die Verweigerung der Erfüllung eventueller weiterer Vertragspflichten und die Annullierung der Auslieferung weiterer, laufender Bestellungen, ohne dass der Käufer Entschädigungen, Ersatz oder ähnliches fordern kann.

#### 7. Solve et Repete

Keine Ausnahme, außer bei Nichtigkeit, Annullierbarkeit oder Rücktritt vom Vertrag, kann vom Käufer geltend gemacht werden, um die Zahlung zu verzögern oder zu vermeiden.

#### 8. Eigentumsvorbehalt

Wenn die Zahlung aufgrund von vertraglichen Vereinbarungen - ganz oder zum Teil - nach der Lieferung ausgeführt werden muss, bleiben die gelieferten Produkte unser Eigentum bis zu vollständigen Bezahlung des Preises.

#### 9. Garantie und entsprechende Schiedsklausel

Unser Material wird in Bezug auf die Konformität mit den derzeit gültigen UNI-DIN-EN-Normen garantiert. Unsere Garantie ist auf das Material der ersten Wahl begrenzt, mit einer Toleranz von ca. 5%. Gleich welche Garantie gegen Mängel ist deshalb ausdrücklich für das Material der zweiten und dritten Wahl oder das Stockmaterial und für Sonderangebote ausgeschlossen. Bei den Kollektionen der Ceramica Fondovalle handelt es sich um Material, das chromatischen Veränderungen unterliegt, so wie es ausdrücklich in unseren Katalogen angegeben ist. Vor der Verlegung muss das Material kontrolliert und gemischt werden. Reklamationen für bereits verlegtes Material werden nicht akzeptiert. Eventuelle Reklamationen und Beanstandungen müssen, bei sonstigem Verfall, innerhalb einer unwiderruflichen Frist von 8 Tagen nach Materialempfang und auf jeden Fall vor Weiterverkauf an Dritte, per Einschrieben, ausschließlich an unseren Verwaltungssitz in Torre Maina gemeldet werden. Die Verlegung des Materials bewirkt den Verfall des Mängelrügerechts für offensichtliche oder versteckte Mängel und stellt den ausdrücklichen Verzicht auf die Garantie nach Art. 1490 ital. BGB dar. Die Unterschiede in den Farben können nicht als Materialmangel reklamiert werden. Auf jeden Fall sieht unsere Garantie ausschließlich den Austausch des als defekt angesehenen Materials vor, mit Ausschluss jeder weiteren und anderen Verpflichtung. Eventuelle Reklamationen des Materials berechtigen den Käufer nicht die innerhalb der vereinbarter Fristen durchzuführende Zahlung, insgesamt oder zum Teil, einzustellen oder zu verzögern, im Sinne des vorhergehenden Artikels 7. Jede Unstimmigkeit im Zusammenhang mit der Feststellung der Mängel, dem Recht auf Garantie, der Bestimmung des Schadens und seiner Quantifizierung, die nicht über eine gütlich Einigung zwischen den Parteien beseitigt werden kann, wird einem freien Schiedsspruch durch einem Schiedsrichter unterstellt, der nach der Verordnung der beim Keramikzentrum in Bologna eingerichteten Schiedskammer erfolgt. Die Parteien verpflichten sich, diesen Schiedsspruch vorbehaltlos und unanfechtbar zu akzeptieren.

#### 10. Zuständiger Gerichtsstand

Unbeschadet der im Punkt 9 enthaltenen Bedingungen ist der alleinig zuständige Gerichtsstand für alle Streitfälle das Gericht Modena.

#### 11. Effektivität jeder Bedingung

Die oben aufgeführten Allgemeinen Geschäftsbedingungen dürfen nicht als reine Stillklauseln verstanden werden. Sie sind effektiv und stellen getreu die Verhandlungsabsicht der Parteien dar.





Ceramics of Italy

AD: Marketing Dept.

02/2024

© Ceramica Fondovalle S.p.A.

È vietata la riproduzione, totale e parziale  
del catalogo in tutte le sue forme.

Reproduction of this printed catalogue  
totally or partially, is forbidden.

Ceramica Fondovalle si riserva di apportare,  
qualora lo ritenesse opportuno, eventuali modifiche  
di natura tecnica o formale ai dati riportati in questo strumento.  
I colori sono puramente indicativi.

Ceramica Fondovalle reserves the right, when it deems necessary,  
to make technical and formal changes to the data included herein.  
The colours are purely illustrative.

# FONDOVALLE

**Ceramica Fondovalle S.p.A.**

Via Rio Piodo, 12  
41053 Torre Maina, (MO) Italy  
T. +39 0536 934211  
F. +39 0536 934250  
[www.fondovalle.it](http://www.fondovalle.it)

A company part of



**ITALCER - WINNER OF THE  
2022 SUSTAINABILITY AWARD**



0



